

# Advantech Industrial Automation Application Stories

## Vertical Market Solutions



Building Automation & Energy Management

Environmental Monitoring & Facility Management

Machine Automation & Factory Automation

Intelligent Transportation System

Power & Energy Management



**ADVANTECH**

*Enabling an Intelligent Planet*

[www.advantech.com/eA](http://www.advantech.com/eA)

## About Advantech



### Introduction

Founded in 1983, Advantech is a leader in providing trusted innovative embedded & automation products and solutions. Advantech offers comprehensive system integration, hardware, software, customer-centric design services, and global logistics support; all backed by industry-leading front and back office e-business solutions. We cooperate closely with our partners to help provide complete solutions for a wide array of applications across a diverse range of industries. Advantech has always been an innovator in the development and manufacturing of high-quality, high-performance computing platforms, and our mission is to empower these innovations by offering trustworthy automation products and services. With Advantech, there is no limit to the applications and innovations our products make possible.

### Building Automation

P.3

- Intelligent Hotel Application with Advantech WebAccess P.4
- Smart Home Management System P.5
- Centralized Heat Supply & Exchange System P.6
- Intelligent Office Building Monitoring System with Advantech WebAccess P.7
- Video Surveillance in a County Jail P.8
- Energy Conservation and Efficiency in Shanghai Office Building P.9
- The Cost-Effective Solution for Building Energy Management in Suzhou Industrial Park P.10

### Environmental Monitoring & Facility Management

P.11

- Municipal Sewage Treatment Plant Networking System P.12
- Dam Monitoring and Control System P.13
- GIS Railway VOIP Communication System P.14
- Wartime Simulation Facility for Military Response Training P.15
- Intelligent Tunnel Lighting Control System P.16
- Coal Mine Automation System of Weight Checking and Fraud Prevention P.17
- Fiber Optic Ethernet Based Communication for Coal Mining P.18



# Table of Contents

## Machine Automation & Factory Automation

P.19

- Hard Drive Manufacturing Quality Control System P.20
- External Rotor Stator Winding Machine P.21
- Multi-axis Ceramic Resistor Test Machine P.22
- Laser Marking System for Disk Media P.23
- Steel Factory Control & Monitoring System P.24
- Jet Engine Test System P.25
- LED Die Bonding Solution P.26
- Ethernet Switches for an Automotive Production Line P.27
- A Tobacco Production Automation System for Controlling and Monitoring Tobacco Plants P.28
- Touch Panel Linearity Test Solution P.29
- Solar Cell Test Solution P.30

## Intelligent Transportation System

P.31

- Passenger Information Display System (PIDS) P.32
- Fiber Optic Train Station Communication System P.33
- Automated Circulation System for Railway Transportation P.34
- Surveillance and Monitoring System over Power Substations in Beijing Subway P.35
- Parking Lot Monitoring System at Highway Service Area P.36
- Display Panels for Subway Trains P.37
- Dynamic Weighing System P.38
- Train-driving Simulator Optimization Using Advantech's Distributed Control System P.39
- China Railway High-speed Maintenance System P.40

## Power & Energy Management

P.41

- Solar Thermoelectric Control System P.42
- Sun Tracking System for Solar Energy P.43
- Control Solution for Solar Energy Monitoring System P.44
- Photovoltaic Plant Management Solution P.45
- A Total Solution Elevates the Performance of a Wind Farm P.46
- Standalone Fuel Cell Power Generation Station P.47
- Advanced Power Management Station P.48
- Monitoring Quality and Consistency of Electricity Supply P.49
- A Total Solution for Electronic Vehicle Charging Stations P.50

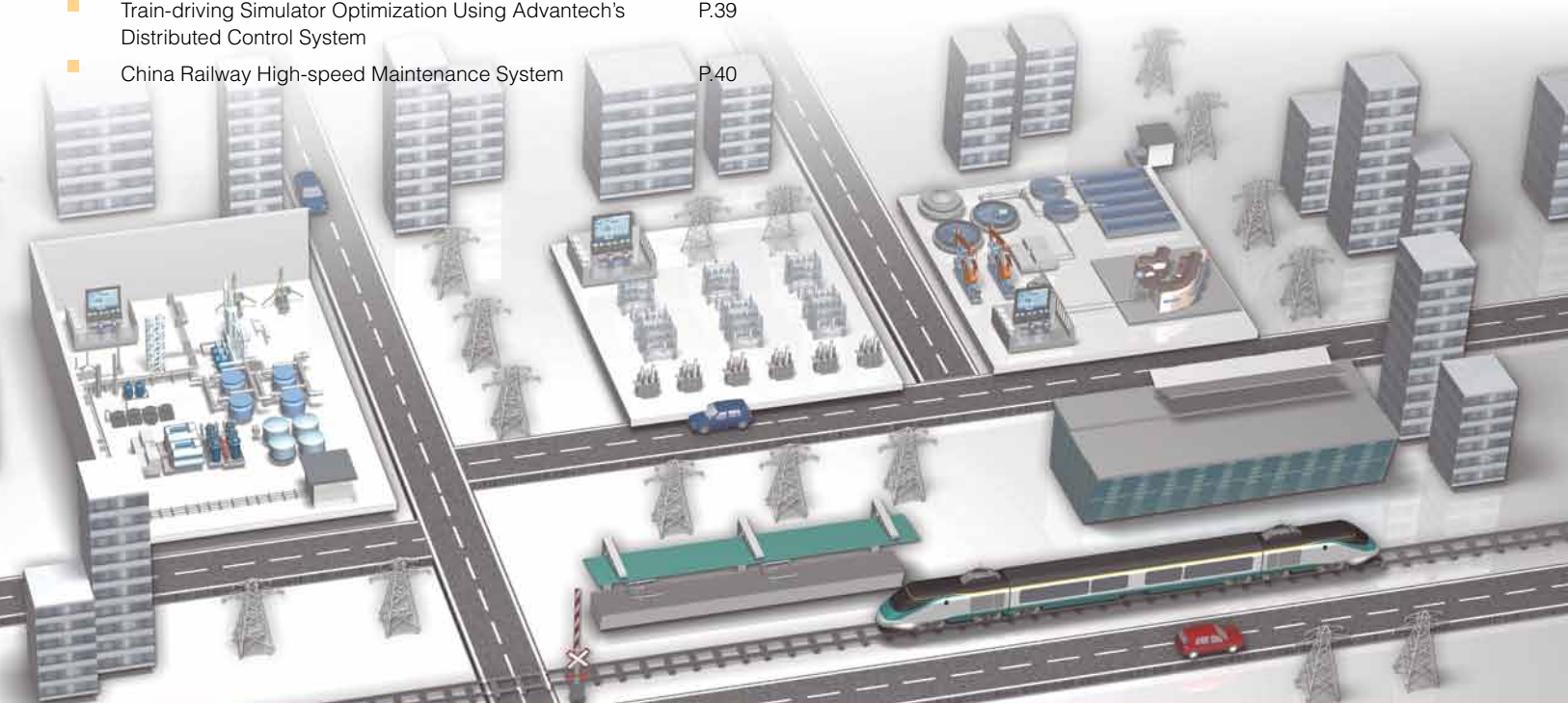

# Building Automation

## Increase Energy Efficiency with Open and Web-enabled Technologies

Integrated facility management systems are becoming more popular as they help make building operations run more efficiently through advanced control and connectivity. In addition to integrated facility management, video surveillance systems offer advanced security for facility managers. Advantech's Building Automation and Energy Management Solutions offer browser-based software and comprehensive hardware packages for a variety of applications, including Advantech WebAccess, Advantech's BACnet controllers and remote I/O modules, energy data concentrators, and power meters. It enables engineers, system integrators and equipment manufacturers to maintain and upgrade their systems remotely.

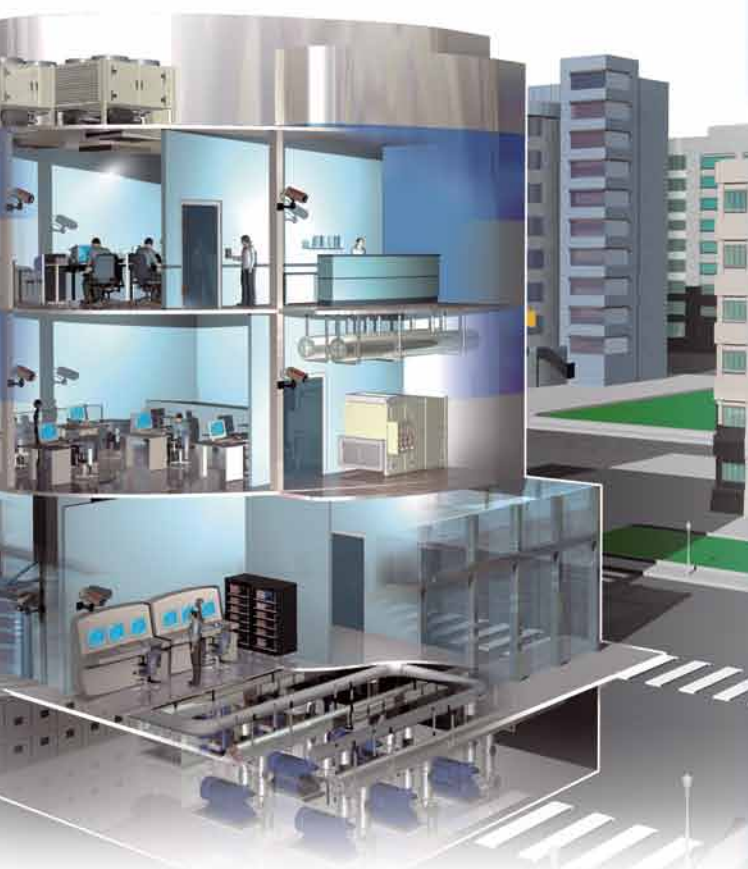

### Integrated Facility Management Systems

Integrated Facility Management Systems enable facility managers to orchestrate various building automation systems within one or multiple facilities. Remote management capabilities help maximize energy efficiency for many applications, such as HVAC, lighting, and surveillance.



### HVAC System Management

Reducing power usage of HVAC equipment is the most effective way to decrease costs as it is a major source of power consumption. Executing energy saving methods through employing cooling storage, improving cooling towers, and adopting secondary chilled water pumps is useful to optimize energy efficiency.



### Lighting Control Systems

Lighting systems are secondary parts of power consumption. By implementing automated lighting control systems and daylighting schemes as well as offering environmentally friendly lighting is very important for facility managers.



### Video Surveillance Systems

Video surveillance systems play an increasingly important role in the security of building automation. They offer secure environments and protect assets for multiple buildings by continuously improving the images which are monitored, analyzed, and archived to enhance effectiveness.

## Product Solutions

### Software



**Advantech WebAccess**  
Browser-based HMI/SCADA Software

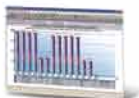

**Advantech BEMS**  
Building Energy Management Software



**PowerView**  
HD Video Surveillance

### Industrial Computers



**IPC-610**  
4U 14-Slot Rackmount Chassis

### Controllers



**BAS-3000**  
BACnet & Modbus DDC Controller

### Communication



**EKI-2525**  
5-port Industrial Ethernet Switch

### I/O



**BAS-3000BC**  
BACnet I/O Modules



**ADAM-2520Z**  
Wireless Modbus RTU Gateway

# Intelligent Hotel Application with Advantech WebAccess

China



## Introduction

The goal of having an intelligent building starts with early planning in the design stage. There are enormous benefits to be gained by creating intelligent buildings. The Pullman South Hotel in Beijing is managed by the Accor Group in France and is seated in the central area of the new Economic & Technological Development Area. With 19 floors, the hotel is equipped with guest rooms, dining, and entertainment and recreation facilities.

## System Requirements

The Pullman South Hotel required a system to control the numerous sub-systems within the hotel, such as a cold source system, heat exchanger system, air-conditioning monitoring, fresh air system monitoring, air supply & exhaust system monitoring, water supply & drainage system monitoring, transformer & distribution electric system monitoring, and lift system.

All field electric devices are distributed to every corner of the hotel. The hotel required an intelligent monitoring system that was network based, with distributed control and remote monitoring capabilities. They wanted to combine intelligent control system and management solution to create comfortable and warm accommodation whilst reducing the material and energy costs within the hotel.

## System Description

The Pullman South Hotel applied Advantech's BAS building automation control system, including Advantech WebAccess upper monitoring software, BASPro logic programming software, BAS-3500 series controller and other various control and expansion modules, which intensively manage and control the electromechanical devices in the building.

Its central monitoring system is used to monitor the working condition of all devices. For example, it shares real-time communication with freezer units through the Modbus interface and monitors device conditions, and the field controller within the equipment room controls relevant field devices. Various high precision components also capture the temperature and humidity information in the hotel, and adjust the blower and humidifier through the field controller (DDC) in the air-conditioning room, so as to ensure consistent air, humidity and temperature in the hotel. The hotel's air supply & exhaust system relies on a central system to monitor all exhaust units' working conditions and air machine's manual and automotive state shift to ensure whether air units are in building automotive system state. When the system is abnormal, it will display the field conditions on screen in the central monitoring room through network communication, and send a voice alarms to remind working staff, and the important data can also be printed as records. The central system also monitors the water supply and drainage system in the hotel to ensure a stable water supply and its usage.

## Conclusion

Advantech WebAccess software is aimed at being the ultimate control system for any intelligent building project. In this application, it is integrated into the Pullman South Hotel in Beijing to ensure all devices not only work safely and reliably, but also provide energy saving capabilities while extending the life span of devices. With Advantech's stable, reliable and efficient building automation control system, the Pullman South Hotel can save much more energy than before.

## Project Implementation

Products	Specifications
<b>Advantech WebAccess</b>	Browser-based HMI/SCADA Software
<b>BASPro</b>	BAS-3000 DDC Programming Tool
<b>BAS-3500</b>	Web-enabled DDC Controller

## System Diagram





# Smart Home Management System

Taiwan

## Introduction

Smart homes are living areas that have been equipped with automated lighting and electronic devices that provide a wide range of intelligent features. Many new solutions also provide the ability for homeowners to use mobile phones or PDAs to remotely manage these systems, seamlessly interconnecting technology and home life. In the recent years, these solutions have made significant improvement to their added-value services and offerings, but high reliability will always be the most important.

## System Requirements

Because these houses are sold without any electronic devices or lighting equipment, smart home system integrators need highly reliable systems that can easily connect several devices without any interference. Moreover, they wanted the ability to remotely manage the entire system through the Internet.

The following are the detailed requirements:

- High isolation
- Supports for standard COM port interfaces in order to connect with various electronic devices
- Fulfills both digital input and output requests in one module
- Supports Modbus protocols
- Control panels with color LCD

## System Description

UbiQ-230 allows customers to send demands wirelessly from remote controls, cell phones, or PDAs and then issue commands through RS-485 to an ADAM-4055. The ADAM-4055 can handle eight control on/off switches simultaneously, such as opening or closing curtains, turning on or off air-conditioning, lighting, stereo systems and more. Moreover, with isolation protection, the ADAM-4055 prevents all electronic devices from interfering among others.

## Conclusion

The goal for smart homes is to allow customers to control all electronic devices with one click. Combining the UbiQ-230 and ADAM-4055 enables to act closer to an ideal solution and provides more accurate, efficient, and reliable system for customers.

## Project Implementation

Products	Specifications
ADAM-4055	16-ch Isolated Digital I/O Module with Modbus
UbiQ-230	One-Touch Scenario Control Panel with 3.5" Color LCD

## System Diagram

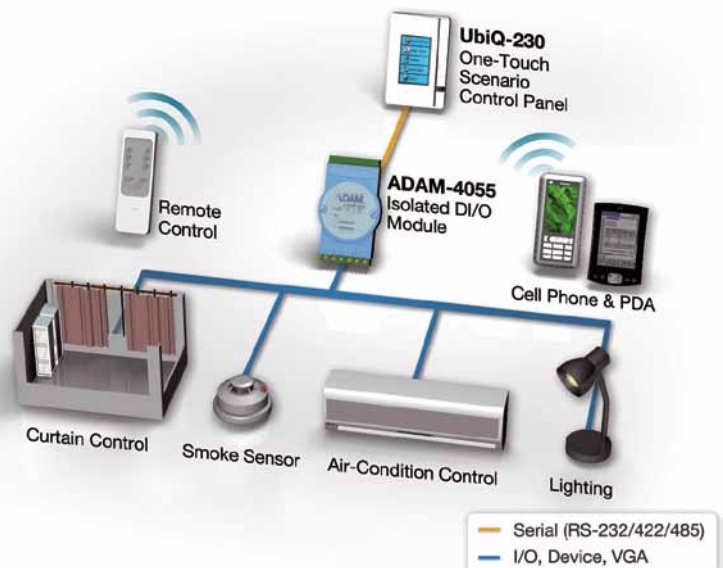

# Centralized Heat Supply & Exchange System

China



## Introduction

Centralized heating supplies are an important part of energy-saving in any large building, and one of the main components of urban modernization. Heating supply systems mainly include heating stations, a complete water pipe network, heat exchange station, and more.

## System Requirements

A large residential complex in China turned to Advantech for help setting up a comprehensive heating supply and exchange system with monitoring capabilities, control, and remote functionality. They wanted to be able to monitor and control the inlet & outlet water temperature and the pressure of the primary and secondary pipelines. Water flow in the primary network of the heat exchange station and details on activity in the circulation pump and pump transducer must also be monitored.

## System Description

The heating supply system for the residential community includes the water pipe network and heating station. The pipe network is further divided into primary and secondary networks, with the former referring to the pipeline network between the urban pipeline network and heating station while the latter referring to the pipeline network between heating station and the community itself.

The control room meters and controls devices connected to the primary and secondary networks for heat exchange, heat dispatching, system monitoring and adjustments. As shown in the system diagram, an ADAM-4017 is used with flow meters and pressure meters to detect flow rate and pressure variations. ADAM-4022T measures temperatures through an RTD thermometer and adjusts the flow rate with PID functions. ADAM-4024 is used to control the inverter drive. All of the ADAM devices can be monitored with Advantech WebAccess SCADA software. This system is used to adjust and maintain heating parameters (voltage, temperature and flow) to guarantee the heat supply runs safely and economically; therefore, functions and features of heat exchange automotive control system are very important; the monitoring and controlling core is for primary and secondary networks' inlet and outlet water temperature, voltage, flow, conditions of circulation pump and make-up water pump, start and stop control, spin speed, malfunctions, electric quantity and other parameters. To improve the operating efficiency and management quality, the heat supply dispatch department needs to conduct centralized and real-time monitoring of temperature, voltage, flow, liquid levels, device conditions and many other parameters of the distributed heat exchange stations, remote control of the running of devices in the heat exchange station.

## Conclusion

After implementation, the management staff of the residential complex was able to achieve complete monitoring and control for both the primary and secondary networks in the heat exchange system. This allowed them to provide their community with improved service while increasing their energy saving and efficiency by a large margin.

## Project Implementation

Products	Specifications
Advantech WebAccess	Browser-based HMI/SCADA Software
ADAM-4017	8-ch Analog Input Module
ADAM-4022T	2-ch Serial-based Dual Loop PID Controller with Modbus
ADAM-4024	4-ch Analog Output Module with Modbus
ADAM-4501	Ethernet-enabled Communication Controller with 8 x DI/O
TPC-1070H	10.4" SVGA TFT LCD Intel® Celeron® M Touch Panel Computer

## System Diagram

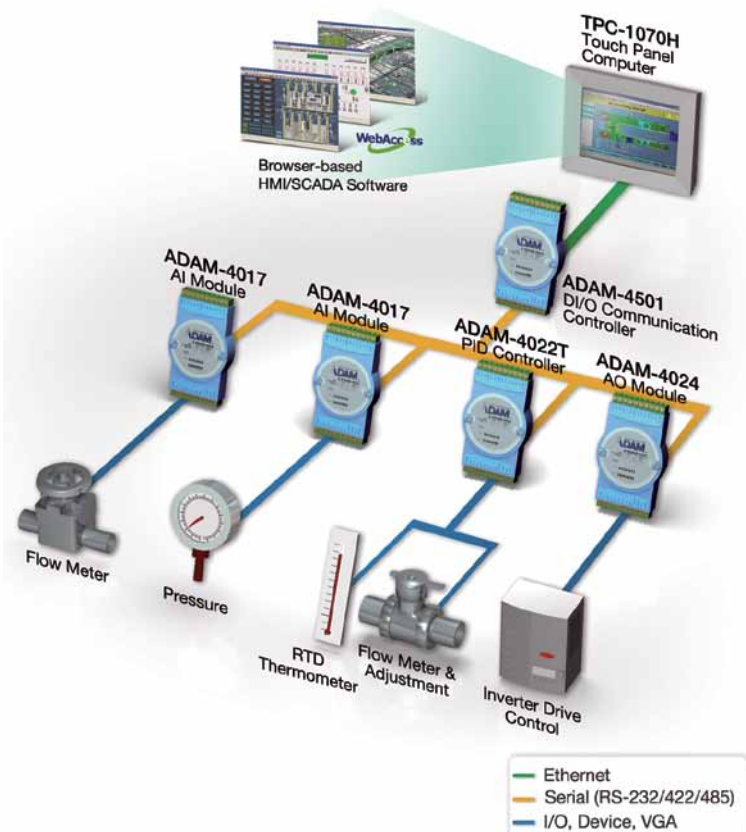



# Intelligent Office Building Monitoring System with Advantech WebAccess

China

## Introduction

Intelligent office buildings are products of the information age; combining computers, telecommunications, control and architecture technologies. A multinational entrepreneur group was developing an office center in China with the goal of establishing a modern, advanced intelligent building. They were looking for a control system with integrated automation software to link the building monitoring system, guard monitoring system, access control, and parking management system, and turned to Advantech to help complete the solution.

## System Requirements

The monitoring software needed to support the popular LonWorks Modbus bus standards, including; Modbus, SOAP, XML, HTTP and other communication protocols. It also needed to support the Universal Plug-and-Play(UPnP) protocol for intercommunication, and DDE, OPC, ODBC, SQL, API and other data access methods with excellent open and intercommunication capabilities.

The system needed to provide a friendly and convenient application development environment, facilitating easy planning, design, construction, maintenance and management. Its servers' operating platform needed to support Microsoft Windows NT 4.0, with an upper bus speed of 100 Mbps Ethernet to ensure high-speed operation. A multi-protocol intercommunication control system that could realize Internet openness and ensure decisiveness and integrity of real-time control was also required.

## System Description

The system uses a distributed control system with two levels of network construction. The first level is Ethernet; the second level is the bus, that is, the data transmission network between internal control host and controllers inside all sub systems. These two levels of network share data within all sub systems through standard data interfaces opened by Advantech WebAccess, including ODBC, DDE, OPC as well as Modbus and LonWorks bus protocols.

The IBMS system includes a building automotive control system, guard monitoring system, and access control and parking management system. Advantech WebAccess' solution provides an advanced network technology with stronger transmission calculation, higher real time accuracy and safer network control. Advantech WebAccess is based on the TCP/IP protocol, so no matter how complicated the network system is, or even across multiple network locations, it can achieve the field monitoring effect, and is unlimited by the network hardware medium, regardless whether it is a telephone line or fiber optic cable. It also provides accurate malfunction diagnosis for engineering maintenance. Since Advantech WebAccess network configuration software has remote diagnosis and maintenance functions, when the system fails, a field operator only needs to access to the Internet to solve system issues: they can finish diagnosis and maintenance within a very short amount of time. When a field alarm occurs, Advantech WebAccess will not only notify the operator through the display interface, but also through e-mail, messages and more. Furthermore, Advantech WebAccess displays real-time images in the video subsystem using network cameras and building monitoring interfaces on the same monitoring screen, allowing operators to see real time field images.

## Conclusion

Advantech WebAccess is integrated in this case to ensure all devices work safely and reliably. It also helps to increase energy saving. With Advantech's stable and reliable building automation control system, the office can operate more efficiently.

## Project Implementation

Product	Specification
Advantech WebAccess	Browser-based HMI/SCADA Software

## System Diagram

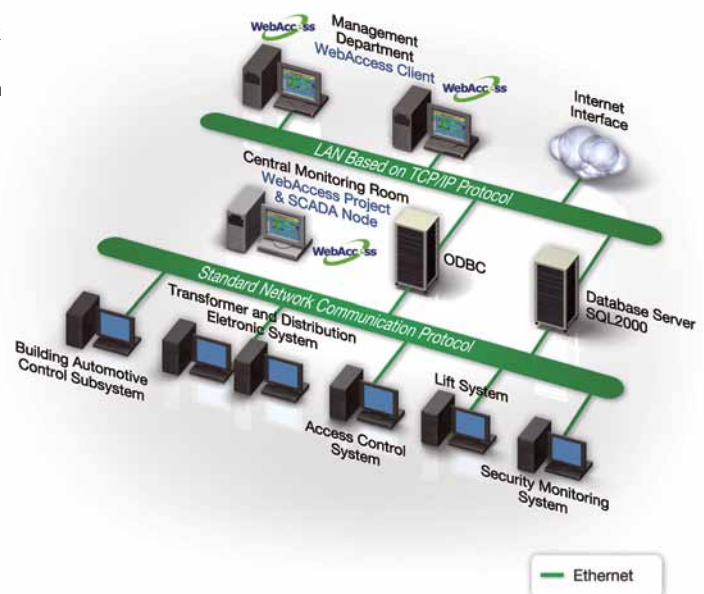



# Video Surveillance in a County Jail

United States



## Introduction

As crime increases, the size of the jail system must increase as well. To ensure safety of the prisoners, guards, and other employees, a high-tech automated video and control system is needed. Guards cannot be in all locations at all times and prisoners are not always supervised.

## System Requirements

A large county jail with over 800 inmates needed to update their security video and lock system to ensure the safety of all individuals housed or working at this facility. The system needed to be both analog and digital and meet a lot of security specifications.

## System Description

Cameras are located throughout the facility including at each door where there is lock controlled by a central location. Advantech uses multiple EKI switches connected to IPCs, PCAs, and PCLs that eventually connect to an Advantech FPM in a central monitoring area. The guards monitoring these displays can control door locks and the cameras from this location.

## Project Implementation

Products	Specifications
ADAM-5000/TCP	8-slot Distributed DA&C System for Ethernet
ADAM-5050	16-ch Universal Digital I/O Card
EKI-4654R	24+2 SFP Managed Redundant Ethernet Switch
EKI-7626C	16+2G Combo Port Gigabit Unmanaged Industrial Ethernet Switch
FPM-3180	18" Industrial Flat Panel Monitor
PCL-722	144-ch Digital I/O ISA Card

## System Diagram

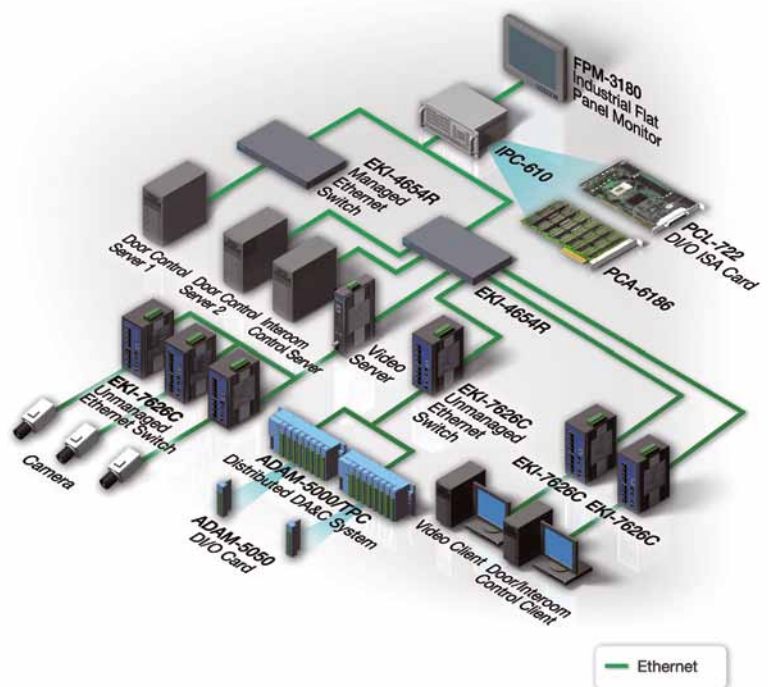

## Conclusion

The system works great and fulfills the needs for extensive coverage with centralized monitoring, ensuring safety and reliability. The safety of all individuals has improved and less manpower is needed to ensure all inmates are monitored. Issues are avoided ahead of time and reaction to any problems is much quicker. This project has much potential to be incorporated in other security locations.



# Energy Conservation and Efficiency in Shanghai Office Building

China

## Introduction

Conservation of energy resources through energy management solutions is receiving considerable attention in the modern office building sector. Specific questions are directed towards average monthly energy costs and energy consumption. Meanwhile administrators need to have sufficient information about the state of their facilities' to plan energy conservation. For those reasons, new office buildings are usually embedded with advanced technology energy efficiency features to monitor their electricity and water resources to detect leaks in the building's plumbing and facilities usage to reduce energy costs as well as providing a comfortable office environment.

## System Requirements

The Shanghai Hung-Xiang Building was completed in June, 2011. This new office building with 15 floors and 3 basement levels, implemented the Building Energy Management System (BEMS) to effectively monitor its equipment usage, especially in terms of electricity and water. Because of its large building area, the building needed more than a thousand monitoring points to collect details of the facilities' conditions and control several subsystems, including fresh air handling units, heat pumps, water supply and the facilities' energy conservation devices. All of the data has to be transmitted to the energy management system to help the supervisor to fully understand the situations of each floor.

## System Description

Advantech's Building Energy Management System (BEMS), combines two major hardware devices. The first item is a 20-ch BAS-3520 Web-enabled DDC Controller that delivers various onboard I/O's to satisfy versatile application requirements and is installed on each floor to control and monitor the chiller plant, AHU and plumbing facilities. The second device is a BEMG-4110 Energy Data Concentrator that is in charge of data collection from water and power meters.

In addition, the browser-based HMI/SCADA software - Advantech WebAccess is another key segment for any BEMS. Advantech WebAccess application provides remote control and management allowing users to easily view, control, and configure automation equipment in building automation systems. Through the use of data acquisition devices and real-time data control software, the administrator can easily control and manage all the devices in a building via Advantech's BEMS.

## Conclusion

In this case, the new architects adopted Advantech's building automation solution to acquire the facilities' data and generate energy consumption reports so that the building administrator can effortlessly control the facilities in real time whilst being able to receive periodic reports to help them to analyze and adjust the building's energy consumption to achieve greater energy efficiencies. Furthermore, Advantech's solution can provide more I/O points for the future expansion.

## Project Implementation

Products	Specifications
Advantech WebAccess	Browser-based HMI/SCADA Software
BAS-3520	20-ch Web-enabled DDC Controller
BEMG-4110	Energy Data Concentrator with 4 x COM, 1 x LAN

## System Diagram

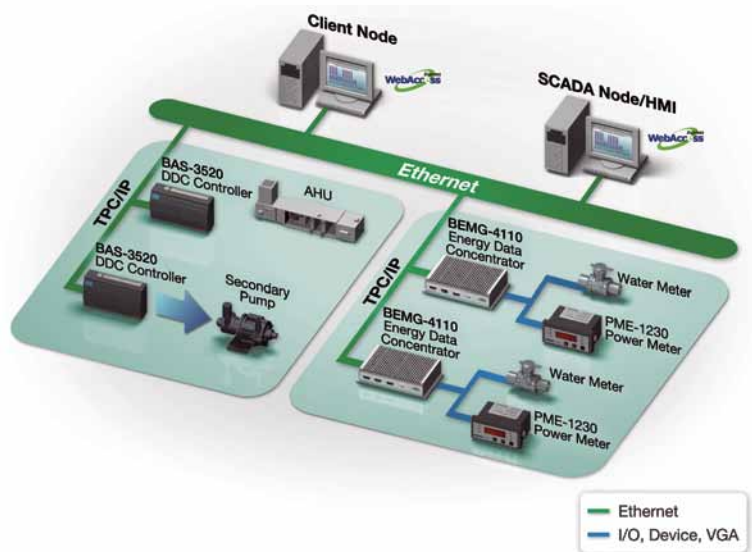

# The Cost-Effective Solution for Building Energy Management in Suzhou Industrial Park

China



## Introduction

Every day, a massive amount of energy is wasted on fuelling buildings. According to statistics, buildings consume 40% of all energy on our planet. Since energy efficiency is a hot issue on a global level, energy efficient buildings are becoming more and more important. However, it is not easy to implement a user-friendly, cost-effective solution for a single enterprise with clustered buildings. To monitor their energy conservation, Advantech provided web-based products to fulfill such Building Automation requirements.

## System Requirements

Our client's three buildings (factory, warehouse and office) are located in Suzhou Industrial Park in mainland China. In order to complete the energy monitoring plan, this new plant needed to connect 1,500 points to comprehensively monitor and control its facilities i.e. air conditioning units, fan coil units, inverters, electricity meters, gas meters etc. Because the system uses many devices from different vendors, there is a necessity for compatibility with the communication devices which collect the facilities' data such as temperature, humidity, voltage and power current.

## System Description

Advantech provided 30 sets of web-enabled DDC & I/O modules and the browser-based Advantech WebAccess HMI/SCADA software to satisfy our client's energy monitoring demands. Advantech WebAccess is installed on a computer in the control center, offering a greater ability to integrate with third party devices, including gas meters, power meters, inverters and digital network thermostats via an RS-485 Modbus to connect to a 24-port Ethernet Switch without DDC; meanwhile it features of animated graphical display, real-time data control, trends, alarms and logs enable users to easily browse the monitoring status.

This integration, directs BAS-3000 series digital controllers connected to the different devices to acquire various analog and digital signals and deliver the data to a host via a 24-port Ethernet Switch. A Direct Digital Controller (DDC) with an easy-to-use graphical programming tool can provide automotive controls such as scheduler, HVAC calculation, sequential control, PID control, alarm and messaging to achieve the saving of energy. Furthermore, the Building Energy Management System (BEMS) with the gathering of data can generate the report to assist administrators to analyze the facilities' conditions and adjust their configuration or fix the problem.

## Conclusion

Efficient features may be either embedded in new buildings or added to existing buildings through energy retrofits but both of them can lessen demand on the power grid, decrease stress on gas supplies and save consumers' money. In addition, conservation and efficiency measures can be as simple as adopting Advantech's Building Automation solution for customer's multiple buildings and the customer can also save a lot of money via the communication integration features of Advantech WebAccess.

## Project Implementation

Products	Specifications
<b>Advantech WebAccess</b>	Browser-based HMI/SCADA Software
<b>BAS-3520</b>	20-ch Web-enabled DDC Controller
<b>BAS-3018</b>	8-ch UI BACnet MS/TP Remote I/O Module
<b>BAS-3024</b>	4-ch UI, 4-ch AO, 4-ch DO BACnet MS/TP Remote I/O Module
<b>BAS-3050</b>	8-ch DI, 8-ch DO BACnet MS/TP Remote I/O Module
<b>BAS-3051</b>	16-ch DI BACnet MS/TP Remote I/O Module

## System Diagram

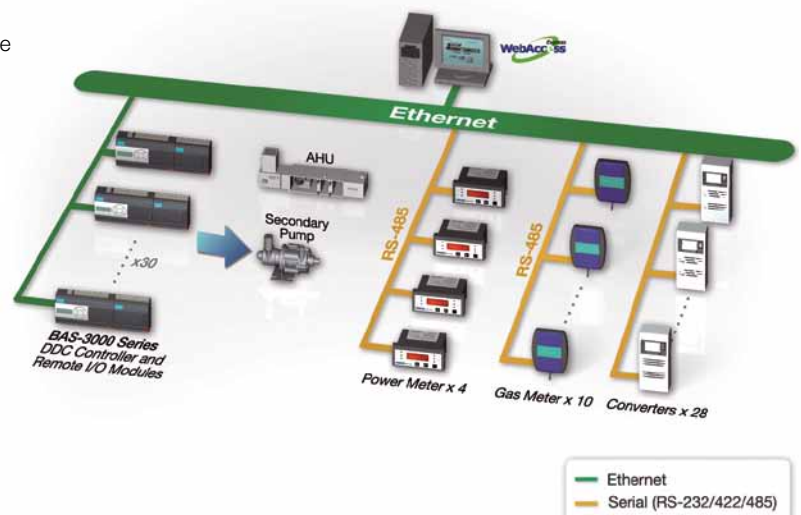

# Environmental Monitoring & Facility Management

## SCADA Software with Video Surveillance and Real-time I/O Solutions

Advantech has been dedicated to developing Environmental Monitoring & Facility Management Systems for many years, especially in dealing with the unique requirements for the water industry. Advantech's value-added systems and solutions through high-volume SCADA and advanced web-based technology allow users to monitor and operate processes anytime, anywhere. Moreover, Advantech offers a wide range of video surveillance, communication, and data acquisition modules with various interfaces. These systems are built with redundant topologies that can be reliably operated even over a long distances and easily integrated with other GPRS systems as well.



### Water & Wastewater Treatment

Water & wastewater treatment plants consist of treatment pools, mixers, pH control pools, and precipitation pools, requiring different process functions and equipment. APAX-5000 & Advantech's Open Embedded Controllers, integrated with Advantech WebAccess, provide complex process capabilities and quality control.



### Pipeline Monitoring

Remote monitoring of pipeline pressure, temperature, flow and leakage is necessary and crucial. Advantech's GPRS device servers, along with APAX-5000 & ADAM-4000/6000, serve as remote monitoring devices. Advantech WebAccess is installed in the central room to monitor values and assess pipeline operations.



### Pumping Station Monitoring & Control

When controlling and maintaining many pump stations remotely, remote transaction is a key issue. Advantech's GPRS devices, Wireless LAN, and fiber optic capabilities provide reliable transaction inquiries, while the APAX-5000 standalone controller handles process applications.



### Disaster Prevention

Advantech's real-time monitoring & control system allows users to not only monitor I/O information from the field, but also provide video surveillance displays through Advantech's redundant X-ring topology to ensure reliable communications.

## Product Solutions

### Software



#### Advantech WebAccess

Browser-based HMI/SCADA Software

### Communication



#### EKI-1322

RS-232/422/485 to GPR IP Gateway

### Controllers



#### UNO-1100H

DIN-rail PCs with Class I, Division 2 Certification



#### APAX-5620

PAC with XScale® CPU and CANopen

### Video



#### NVS-3520

H.264 IP Video Server

### I/O



#### ADAM-4000

RS-485 I/O Modules



#### ADAM-2051PZ

Wireless 8-ch Digital Input Node with Power Amplifier

# Municipal Sewage Treatment Plant Networking System

China



## Introduction

The municipal sewage treatment in Tianjin, China is currently one of the biggest sewage treatment plants in China. Not only is the layout well designed, but many of the systems and processing techniques are the most advanced in the country, with various techno-economic indicators reaching the highest level in China. This plant has applied state-of-the-art Advantech industrial communication products, which can realize the communication between the lower level controllers in each system so as to ensure real-time communication between control systems, monitoring data and the central control room.

## System Requirements

When looking to establish a reliable communication ring within their network infrastructure the Tianjin Capital Environment Protection Group needed switches with strong industrial designs capable of heavy use in their hazardous environment, and products with EMC indicators that conformed to a high industrial grade standard. They also wanted devices using standard 35 mm DIN-rail mounts so as to ensure the device can be directly installed in control cabinet.

## System Description

This system applies state-of-the-art fiber optic Ethernet ring technology, which appropriately combines lower level devices with central control room. The system uses Advantech's EKI-7559MI to constitute an X-Ring – Advantech's ultra-fast redundant ring. The main path in the ring is used as a forward-path; when the Ring Master is set, a backup path is generated. If any link in the ring is broken, the Ethernet ring will activate the backup path automatically (within 10ms) to ensure normal communication. The industrial designed EKI-7559MI combined with a stable and reliable redundancy mechanism, guarantees the safety and stability of the whole communication system.

## Project Implementation

Products	Specifications
Advantech WebAccess	Browser-based HMI/SCADA Software
EKI-7559MI	8+2 Multi-mode Fiber Optic Managed Redundant Ethernet Switch

## Conclusion

In conclusion, Advantech's EKI series solution optimizes redundancy within a fiber optic Ethernet ring. It also provides excellent management methods and easily upgradeable firmware.

## System Diagram

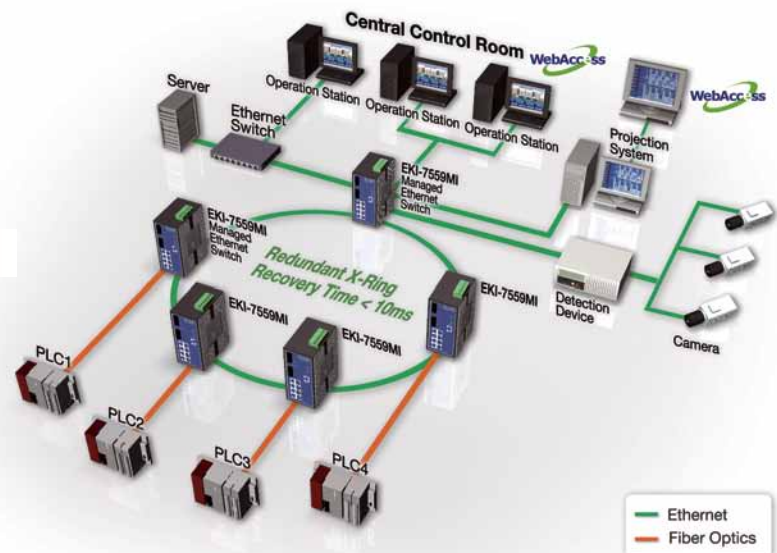



# Dam Monitoring and Control System

Taiwan

## Introduction

Jiaxian Weir is located in the Kaohsiung County in southern Taiwan, about 450 meters upstream from the Jiaxian Bridge. The weir is an extensive facility of the Nanhua Reservoir used to channel water from Qishan Creek into the Nanhua Reservoir. The original equipment that helped control the Jiaxian Weir was damaged by flooding caused by Typhoon Morakot in 2009. It was important to restore the facility before the next typhoon season to prevent a repeat of the disaster.

## System Requirements

The sluice gate control system plays a critical role in monitoring rainfall and water levels in the Qishan Creek so as to transfer overflowing water to the Nanhua Reservoir. The sluice gates will have to operate normally under preset conditions without any errors, or it would become disastrous during a flooding. With the short deadline and weather constraints, the contractors of the project, Sheng Fu Engineering Corporation together with Yi Kung Technology, decided to use Advantech's EKI series of fiber-optic converters and PAC's products for the monitoring control system of sluice gates as these could be installed and configured quickly.

## System Description

To keep a close watch on the amount of rainfall and the status of the weir so as to open or close the sluice gates precisely to prevent flooding, a multi-redundant monitoring system is required. Advantech's APAX-5000 dual redundant control system carries out the mission of monitoring the river and the weir. The dual redundant topology ensures the stability and reliability of an uninterrupted operation of the system and helps to get hold of instant information of weather, water level and water turbidity in order to effectively control the sluice gates and introduces abundant and clear water into the weir for further use.

Meanwhile, Advantech APAX controllers provide I/O modules featuring high point counts, flexible combination and hot-swapping. The remote monitoring and control functionalities enabled the engineers to keep an eye on water level and flow metering, sluice gate openness and water quality, and maintain and control the system with ease.

The APAX-5570 and APAX-5520 are combined to be a dual controller platform that not only separates HMI and SCADA tasks, but also provides a reliable control system. The dual controllers are occupied with separate tasks, with the APAX-5520KW responsible for controlling pumps and other equipment, while the APAX-5570 carries out communications and data process systems. Two sets of dual control hosts were installed to build redundancy, that is, when one set of controllers is down, the other set will take over the work immediately. Furthermore, they adopted two APAX-5343 power supply modules to build dual power supply redundancy, and the APAX-5017 for the data acquisition of water level and flow metering of Qishan Creek, rainfall, and wind direction and humidity of meteorology. The APAX-5040 takes charge of the data acquisition of pump status and water quality while the APAX-5046 is responsible for controlling the sluice gate.

## Conclusion

Under this implementation, Advantech's products have more than met the requirements of this hydro-engineering project, helping the sluice gate monitoring control system operate smoothly and meeting the high standards we had set to prevent floods and disasters.

## Project Implementation

Products	Specifications
APAX-5570	PC-based Controller with Celeron M CPU
APAX-5520	Micro PAC with XScale CPU
APAX-5017	12-ch Analog Input Module
APAX-5040	24-ch Digital Input Module
APAX-5046	24-ch Digital Output Module
APAX-5343	Power Supply for APAX-5570 Series
EKI-2528	8-port Unmanaged Industrial Ethernet Switch
EKI-2541S	10/100T(X) to Single-Mode SC Type Fiber Optic Industrial Media Converter

## System Diagram

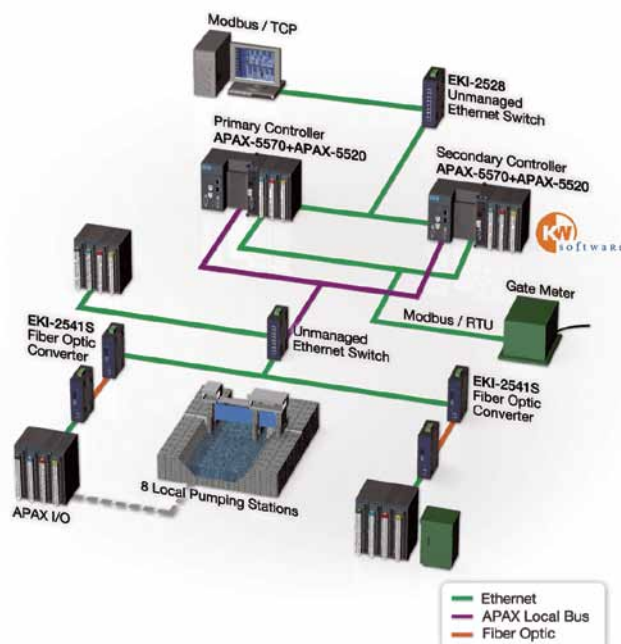

# GIS Railway VOIP Communication System

Italy



## Introduction

GIS Railway in Italy was seeking to develop a VOIP system for their railway applications. They wanted an infrastructure that featured a redundant SHDSL line and allowed connection to a variety of devices, from modern IP interfaces to old analog telephones. This project was very important, as it would lay the foundation for their communications system for many years to come, with many upgrades and expansions already planned.

## System Requirements

The Italian railway company was looking to upgrade their telephone infrastructure to allow integration with advanced features and functions for different environments with redundancy and remote control capabilities. This led to the following requirements:

- 3,000 V<sub>dc</sub> surge protection on the power line
- Products with a wide operating temperature range (up to 60°C)
- Relay output for event alarms on the Ethernet switch
- Redundant power inputs on the Ethernet switch

## System Description

By integrating Advantech's EKI-2528 Ethernet switch, GIS Railway was able to setup a redundant ring across the entire network. It is made with 2 pairs of fiber cables and SHDSL modems. The EKI switches are connected to the modems and connect the phones in the central operation center, the operation managers phone, maintenance, loudspeakers, the telephones on the railway, the VOIP Server (UNO-2170) and the system's HMI (TPC). If the phone is not VOIP ready, an adapter is used to connect the switch and phone.

The TPCs are on the desks of the system managers and are used as the HMI devices. The software on the TPC shows all the connections available on the line, and allows the TPCs to communicate with the servers, trace calls, call someone as a normal phone, create and upload audio messages for the loudspeakers, and activate communications between 2 different types of equipment. Equipment is monitored with remote alarms and it is possible to program it using the onboard web server.

The UNO-2170 works as VOIP server and runs Windows XP.

## Project Implementation

Products	Specifications
EKI-2528	8-port Unmanaged Industrial Ethernet Switch
TPC-1570H	15" XGA TFT LCD Touch Panel Computer
UNO-2170	Intel® Celeron® M Automation Computer with 2 x LAN, 4 x COM and PC/104

## System Diagram

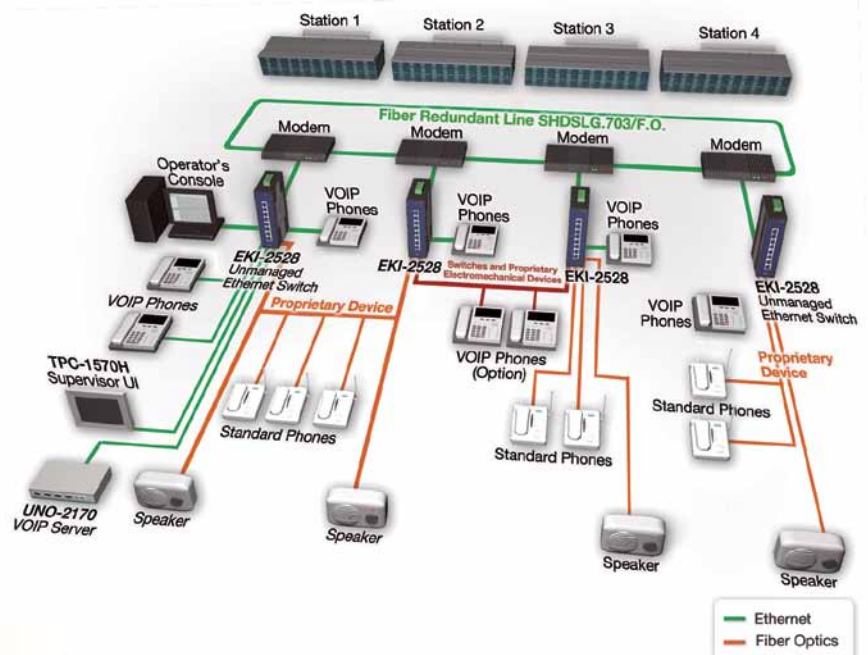

## Conclusion

This new GISAV system has since become a standard VOIP architecture for Italian railways. GIS Railway has been presenting the application to many customers and a demo plant is ready for the demonstrations at the vertical sector exhibitions. Advantech is proud to have supplied high-quality industrial products for this system with local customer support to help implement a state-of-the-art solution for GIS Railway.



# Wartime Simulation Facility for Military Response Training

Taiwan

## Introduction

In order to train soldier responsiveness while under duress, fatigue, and facing the uncertain conditions that occur during wartime, Taiwan recently established a simulation facility to imitate the various circumstances that soldiers face during war. Soldiers are highly monitored during the process to measure reactions, observe mistakes and improve performance and overall responsiveness.

## System Requirements

The ability to think clearly and remain calm under duress is everything in war. The Taiwan government was looking for a system to help them monitor soldier responsiveness: the facility is a two floor building with different rooms that have different equipment (such as weapon ranges, gas vents, and audio speakers). The Independent Remote I/O Modules must have different channels separated across different simulation rooms for different purposes. Once the soldiers enter a simulation room, the equipment needs to receive signals and send them out immediately in order to effectively monitor the soldiers' reactions. Furthermore, all of the installed IP cameras need to be networked through Ethernet, requiring 15M bandwidth per camera to record the reactions of each soldier during the training center.

## System Description

In the simulation center, there are several rooms to test soldier response to different situations that can occur on the battle field. These include (non-lethal) gas, electric shocks, gunfire, blast sounds, and different lighting effects. Thus, these rooms need to be installed with various monitoring equipment and I/O modules to control these events. As shown in the system diagram, there are 33 industrial PC platforms (ACP-4000 with PCB-5124 motherboards) in the center room used to control I/O operations as well as monitor soldier status. The main network is made up of six EKI-7758F switches which establish an X-Ring for redundant functionality. The ADAM-6060, ADAM-6024, and ADAM-6050 connect to the main network through the EKI-7656C switch. The main purpose of the ADAM-6060 (digital input and relay module) is to control the gas, electric shocks and other different effects, while the ADAM-6050 (isolated digital I/O module) is used to control lighting. The loudness and rotation speed of the guns are controlled by the analog input/output module, the ADAM-6024. EKI-7656C is connected to 60 IP cameras used to monitor soldier reactions.

## Conclusion

Advantech's X-Ring redundant architecture maximizes communication reliability, and the whole system is seamlessly connected with Advantech's Ethernet-based remote I/O modules, the ADAM-6000 series, to access real-time data from the field. Advantech provided a total solution for this project, from controllers and communication solutions to remote I/O modules, saving the government from configuration and greatly shortening development time. After implementation of this initial simulation facility, the government was really satisfied with the overall performance of the system, and plans to roll it out across other facilities across the island.

## Project Implementation

Products	Specifications
ADAM-6060	6-ch Digital Input and 6-ch Relay Module
ADAM-6024	12-ch Isolated Universal Input/output Module
ADAM-6050	18-ch Isolated Digital I/O Module
ACP-4000	4U Rackmount Chassis with Visible & Audible Alarm Notification
EKI-7656C	16+2G Combo Port Gigabit Managed Redundant Industrial Ethernet Switch
EKI-7758F	4G+4 SFP Gigabit Managed Redundant Industrial Ethernet Switch
PCE-5124	LGA775 Core 2 Quad CPU Card with PCI Express / IPMI / VGA/ Dual GbE LAN / 6 COM Ports

## System Diagram

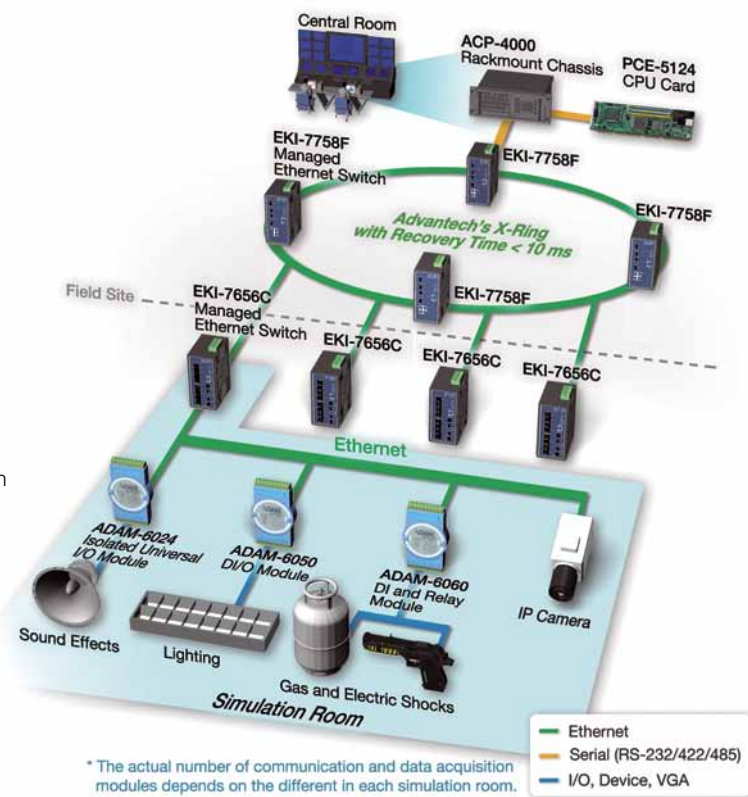



# Intelligent Tunnel Lighting Control System

Taiwan



## Introduction

Jiaxian Weir is located in the Kaohsiung County in southern Taiwan, about 450 meters upstream from the Jiaxian Bridge. The Provincial Highway No.2 stretches through northeastern Taiwan and is one of the major traffic arteries in the region. Two of the main tunnels on the highway were built many years ago, and their equipment was very outdated, with wires and circuits often breaking down. Moreover, they had no remote control and monitoring system, posing safety and security threats to commuters. Advantech's PAC products integrate control, data processing, networking and audio and video functionalities in a single platform, which was perfect as the basis for a lighting and circuit project in the Lanyang Tunnels.

## System Requirements

The sluice gate control system plays a critical role in monitoring rainfall and water levels in the Qishan Creek so as to transfer overflowing water to the Nanhua Reservoir. The sluice gates will have to operate normally under preset conditions without any errors, or it would become disastrous during a flooding. Under deadline and weather pressure the contractors of the project, Sheng Fu Engineering Corporation together with Yi Kung Technology, decided to use Advantech's EKI series of fiber-optic converters and PAC's products for the monitoring control system of sluice gates.

## System Description

In the project, the network equipment for illumination control in Lanyang tunnels is composed of Advantech EKI industrial Ethernet switches with a redundant topology, as well as Ethernet to fiber optic converters, ensuring fast and reliable transmissions. Advantech's APAX-5000 series are used as the main controllers and ADAM-5000 series as sub-system controllers.

APAX-5000 series boast high computing power that can handle large volumes of graphic files and documents. Their unique dual controller scheme allows it to handle different tasks separately, with one controller responsible for acquiring data from project nodes in the tunnels and controlling equipment, while the other is responsible for computing and analyzing data as well as communicating with the network. APAX-5017 is in charge of acquiring data from luminance meters and power meters, APAX-5040 monitoring the status of high-pressure illumination lamps and APAX-5046 controlling the status of the lamps.

ADAM-5051S, a 16-ch digital input module takes charge of monitoring the status of the node lighting and air-conditioning equipment. ADAM-5056S, a 16-ch digital output module, controls tunnel lamps and air-conditioning equipment. A total of 10 sets of controllers were installed in the two tunnels for monitoring supervision. Advantech's APAX-5000 and ADAM-5000 series have dual Ethernet LAN ports to enable fast monitoring, recording, control, storage and remote maintenance functionalities. Fiber optic communications equipment with networking redundancy was established to ensure non-stopping data acquisition and transmission and raise the reliability of tunnel illumination.

## Conclusion

Advantech PAC products, with system architecture of exclusively high flexibility, expandability and reliability, have been applied in monitoring control systems in many industrial applications. They are an excellent choice for transportation monitoring control systems.

## Project Implementation

Products	Specifications
<b>ADAM-5550KW</b>	8-slot Micro PAC with GX2 CPU
<b>ADAM-5051S</b>	16-ch Digital Input Module
<b>ADAM-5056S</b>	16-ch Digital Output Module
<b>APAX-5570XPE</b>	PC-based Controller with Intel® Celeron® M CPU
<b>APAX-5017</b>	12-ch Analog Input Module
<b>APAX-5040</b>	24-ch Digital Input Module
<b>APAX-5060</b>	12-ch Relay Output Module
<b>APAX-5343</b>	Power Supply for APAX-5570 Series
<b>EKI-7654C</b>	4+2G Combo Port Gigabit Managed Redundant Industrial Ethernet Switch
<b>FPM-5151G</b>	15" XGA Industrial Monitor with Resistive Touchscreen, Direct-VGA, and DVI Ports

## System Diagram

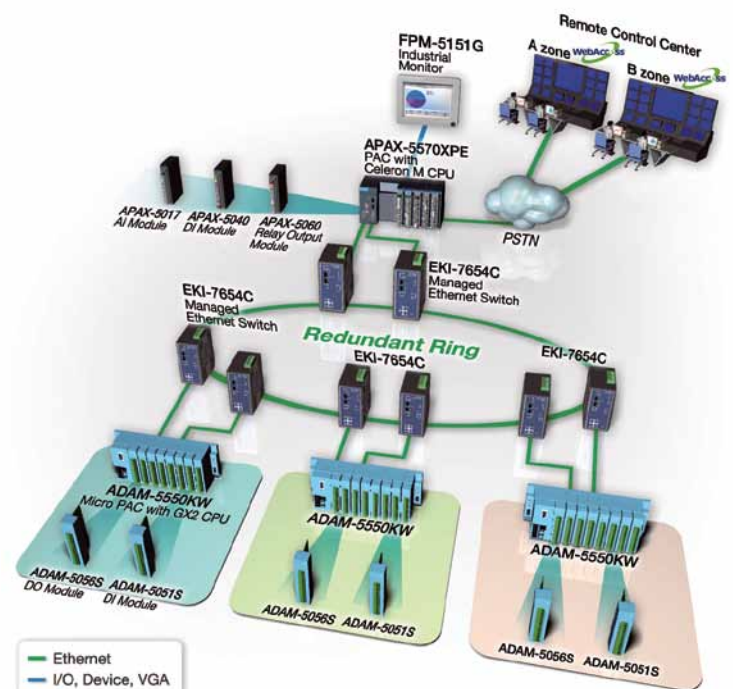



# Coal Mine Automation System of Weight Checking and Fraud Prevention

China

## Introduction

Our customer is a Chinese company who designs and develops weight checking and fraud prevention systems for coal mines and other industrial sites. Coal is transported from the mine to a warehouse, and as with most items, it has value on the black market, therefore to ensure that the correct weight and products arrive at the warehouse, a method of checking is required. Thus, an efficient electronic surveillance system with real time data vision transmission and alarm notice is necessary to control and close watch the delivery of coal.

## System Requirements

In order to develop an efficient surveillance system at coal mines, they need robust and reliable industrial computers with a large number of digital I/O ports to connect and command a number of subsystems including: in-ground truck scale, RFID, remote control, barrier gate control, video, sound and light alarm, infrared, and LED display systems. Because they are to be installed in the coal mines, the harshest of environments, they have to be robust and reliably capable of operating within a wide range of temperatures. Photo-isolated COM ports and digital I/O ports are particularly important, since they minimize interference of communications and protect the main system board. Designed specifically for harsh, dusty environments Advantech's UNO-2050G and EKI-1526 are the best choices for use at coal mines.

## System Description

To build the platform for this application, Advantech's embedded automation computer, UNO-2050G, is paired with an EKI-1526 serial to Ethernet device server, and is controlled using Advantech's industrial touch panel monitor, FPM-3121G, which features wide-temperature and sunlight readability, making it especially suitable for outdoor applications.

The UNO-2050G, is a robust and compact industrial computer which integrates control, communication and other computing functionalities in a small form factor, with 8-ch isolated digital input and 8-ch isolated digital output ports. Its isolated COM ports and isolated digital I/O preventing the environmental intervention make it the ideal choice for operating in the harsh environments.

In this case, the computer system is connected with an IC reader, which can read the RFID tags of the trucks and the items to be warehoused; it is also connected with an in-ground vehicle scale, so it can read the weight of the vehicles at the check point. All the information is collected and transmitted via the EKI-1526 to the UNO-2050G. The EKI-1526 with 2 independent Ethernet ports and MAC addresses provides redundant networking mechanism to ensure the consistency of data transmissions. The data is then sent to the central control room, and is shown not only on the FPM-3121G monitor, but also on an LED display next to the person checking the vehicle's weight.

## Conclusion

The fanless design of Advantech's products allows for stable and reliable operation in ultra-harsh outdoor environments such as coal mines. The UNO-2050G integrates all the needed communications and control functionality with a small form factor, and the large number of ports on the UNO-2050G and EKI-1526 provides great flexibility for developing versatile applications according to actual needs. With all these great features, the Advantech's products described here are the excellent choices for coal mine monitoring applications.

## Project Implementation

Products	Specifications
EKI-1526	16-port RS-232/422/485 Serial Device Server
FPM-3121G	Industrial 12" SVGA/XGA Flat Panel Monitor with Resistive Touch Screen, Direct-VGA, DVI and Wide Operating Temperature
UNO-2050G	AMD Geode™ LX Automation Computer with 2 x LAN, 4 x COM, 8 x isolated DI and 8 x isolated DO

## System Diagram

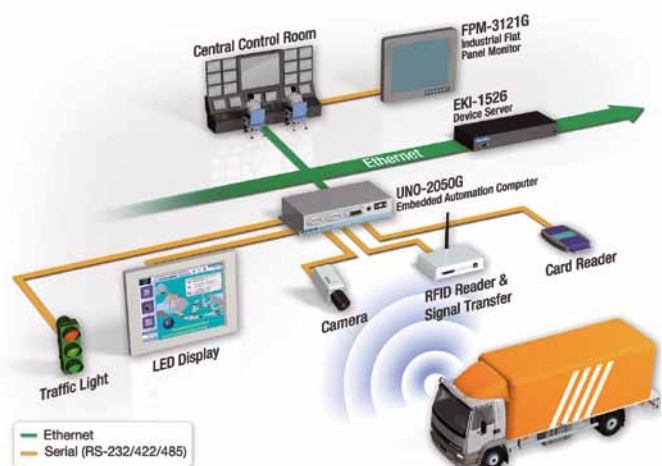

# Fiber Optic Ethernet Based Communication for Coal Mining

China



## Introduction

Coal mine accidents usually result in tremendous loss of lives and money. To avoid tragedies the investment on safety monitoring systems is necessary for modern coal mining industry. Frequent coal-mine accidents prompted the Chinese government to embark on a 50.2 million yuan (or 6.07 million US dollars) plan in 2005 to construct safety monitoring systems in 104 coal mines in 15 provinces. A national overhaul will follow this demonstration program.

The coal mine safety monitoring system relies heavily on reliable information technology that provides secured and rapid data transmission, so that the administrators can detect any abnormal situation in the coal mines just quickly enough for them to take actions to prevent disasters. The detection of hazardous or inflammable gases are particularly important for the security of coal mines, as in China 95 percent of coal mine accidents have been caused by gas blasts. Gases to be cautiously monitored include methane, carbon monoxide, hydrogen sulfide, etc. Thus, Advantech offers reliable solutions of fiber optic-based Ethernet ring for coal mine underground communication networks.

## System Requirements

As any fire spot could cause a catastrophic blast in the underground coal shafts and roadways, the safety monitoring system itself has to be safe or it could become a source of danger. Copper wire-based system of communication cable is therefore not an option for coal mines. Fiber optics is more desirable not only because it is safer here but also because it provides faster and more reliable communications.

On the other hand, the switches and cables deployed in the coal mines must have strong anti-electromagnetic capability to prevent interference from facilities such as power substations in the mines which have motor-driven power adapters inside.

## System Description

Advantech's EKI-7659C switches are deployed in each roadway of the mine to transmit data collected from air sensors located inside the mine, including methane and oxygen concentration, wind speed, smoke, etc. The data is sent to the backbone switch EKI-7657C (three fiber port) via an redundant X-Ring fiber optic network, and then up to the aboveground monitoring and control center.

To avoid electromagnetic interruption, protective components are applied to integrated circuits of the switches, and each switch is enclosed in an explosion proof enclosure to ensure maximum security and reliable operation. The equipment is certified with Chinese MA standards for coal mining security.

## Project Implementation

Products	Specifications
EKI-7657C	7+3G Combo Port Gigabit Managed Redundant Industrial Ethernet Switch with 2 x DI/O
EKI-7659C	8+2G Combo Port Gigabit Managed Redundant Industrial Ethernet Switch

## Conclusion

Advantech's fiber optic Ethernet switches with extraordinary anti-electromagnetic capability and ruggedness provide optimum reliable and secured data collection and transmission network in the adverse underground coal mining environment, which not only help save money but also save lives.

## System Diagram

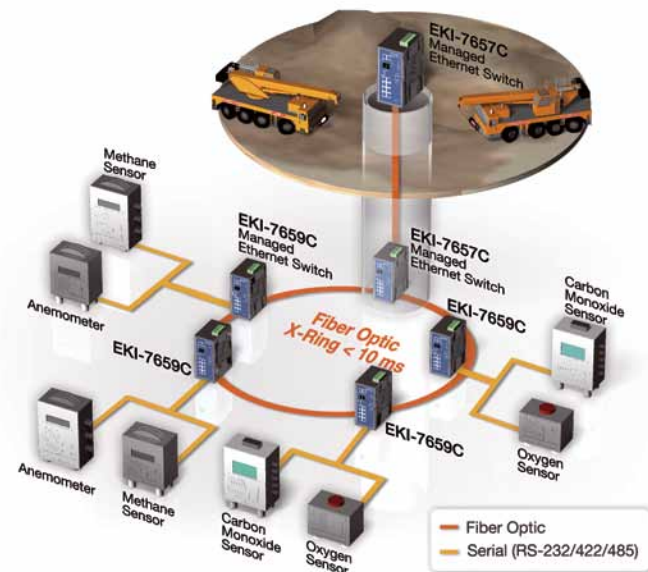

# Machine Automation & Factory Automation

## Highly Flexible Control Systems and Trusted Embedded Solutions

Advantech prides itself on being a leading industrial solutions provider, with over 25 years experience creating robust and reliable industrial products. Advantech's solutions are rooted in factory and machine automation markets, from automatic testing machines and machine inspection, to production, packing and process automation, Advantech not only offers rugged products, but provides professional consulting services to help its suitable customers develop successful applications for a variety of different applications. Now with products that meet the Class I, Division 2 certification for use in hazardous environments, Advantech extends the reach of its professional products even further.

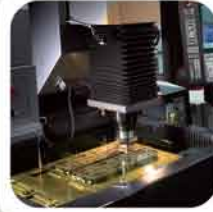

### Automatic Testing and Inspection

Quality control systems have become very expensive in recent years, creating the demand for more cost-effective alternatives. Along with automatic testing and inspection systems, Advantech's products help reduce human error and accelerate time to market.



### Production Automation

Open, embedded architectures with excellent expansion capabilities and high compatibility, and flexible and scalable PACs allow Advantech's customers integrate equipment from a wide range of manufacturers into their systems, and help them meet ever-changing market demands.



### Packing Automation

Delivering a high degree of durability with a low total cost of ownership is a key factor for efficient packaging. By integrating a high-precision motors and high-speed data acquisition cards, packaging machines are able to improve performance greatly, setting up flexible systems that can reduce costs at the same time.



### Process Control

High computing systems with scalable architectures and time-deterministic control are important factors for process control systems. Advantech's solutions allow customers to integrate production information into MES and CIM systems, and fulfill discrete, batch and continuous process control.

## Product Solutions

### HMI



**TPC-1251H**  
12.1" Touch Panel  
Computer

### Controllers



**UNO-3084**  
Wallmount  
Automation  
Computer

**APAX-5000**  
Programmable  
Automation  
Computer

### Communication



**EKI-2748FI**  
8Gx Managed  
Ethernet Switch

### Motion



**PCI-1245/1265**  
Motion Control  
Universal PCI Card

**PCI-1710U**  
Multifunction  
PCI Card

### I/O



**AMAX-1240**  
High performance  
4-axis AMONet  
Motion Slave  
Module

**ADAM-4000/  
ADAM-6000**  
Remote I/O  
Modules

# Hard Drive Manufacturing Quality Control System

United States



## Introduction

Many electronic device manufacturers use machines with PLCs as controllers that need to be able to communicate with a central server for auto process sequence control. A major hard drive manufacturer in the US was facing problems with the communication between their older PLCs and their new server. They desired an automated system that could easily handle communications with the server and provide their engineers with an easy-to-use interface to monitor their HDD manufacturing.

## System Requirements

Charging machines are an integral part of the lapping plate process at many major HDD manufacturers. Previously, this customer had been using a manual lapping plate quality control system which depended on the engineers to verify each plate had been charged before being sent to the polishing machine, which was causing many of their HDD's to be defective. Furthermore, they had recently purchased a new server and found that many of their legacy PLC's were having trouble communicating with it. They needed to automate their quality control process with a reliable system that could communicate with the production server to guarantee quality control for their HDDs.

## System Description

The new system is designed to have auto select recipes, trace and record functions which the original PLC could not do. Advantech provided the FPM-3121G as the industrial monitor and the PCI-1761 to connect to the EMO, safety door switch, on/off buttons, light indicator, alarms and signal control. Every lapping plate has a unique barcode which is scanned and sent to the server to verify the process. After the process has been verified, the system will continue running the process or generate an error code if the lapping plate has not been sent to the charging machine.

## Project Implementation

Products	Specifications
<b>FPM-3121G</b>	12.1" Industrial Monitor with Resistive Touchscreen, Direct VGA, DVI and Wide Operating Temperature
<b>PCI-1761</b>	8-ch Relay and 8-ch Isolated Digital Input PCI Card

## Conclusion

The new system successfully automates the quality control process, significantly increasing the reliability and efficiency of their entire production line. Additionally, Advantech's HMI provides engineers with an easy-to-use interface for monitoring and managing the manufacturing process. Furthermore, the new PC-based system provides a larger memory and an open architecture that is easier for programming and expansion.

## System Diagram

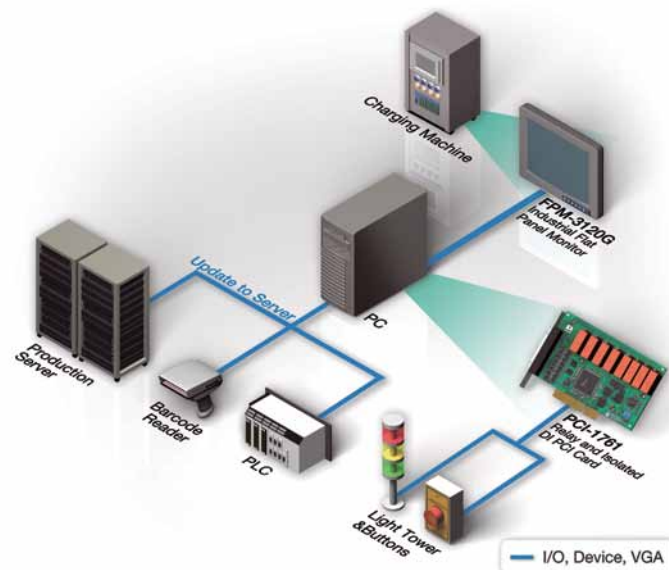



# External Rotor Stator Winding Machine

China

## Introduction

A stator is the stationary part of a rotor system, such as in an electric generator or electric motor. External rotor stator winders are used for automated coil winding in the manufacturing of devices, such as portable electric tools, small electric generators, and electromotors in vehicle engines. This external rotor stator winding machine was built with the help of Advantech, combining motion control and HMI to provide animated displays and self diagnostic functions.

## System Requirements

The goal of this solution was to create a stable and high performance stator winder with a robust computing controller and easy to use interface. Advantech knew the key to this project was to integrate stationary fixtures and hook line protection devices to ensure quick installation of the enameled wire hook, helping realize accurate auto tension control and the ability to store and reference data regarding the rotor winding process.

## System Description

At the heart of this system is Advantech's ADAM-5550KW controller, which is able to connect and control various system devices, such as control buttons, indicators, temperature meters, production data storage, variable frequency motors, etc. The ADAM-5550KW also provides animated displays and self diagnostic functions, which reduces labor intensity and helps increase production efficiency and quality as well.

For the HMI display, the FPM-3121G touchscreen monitor enables users to easily edit, modify, store and encrypt coil data. The system supports rotors of different models, realizes complicated coil winding via multi-axis motion control and meets the requirements of mass production. Furthermore, the programming software is compliant with PLC Open, making it much easier to learn and operate. Various coil winding processes are integrated to realize complicated data processing with the help of the high-speed computing performance of the ADAM-5550KW.

## Conclusion

The automatic stator winder uses Advantech's ADAM-5550KW to meet diverse requirements with strong computing capabilities and large data storage. In addition, the intellectual property of the customer's manufacturing process can be protected with the help of the copy-protect function in the embedded system. As a result, labor intensity has been reduced, while production efficiency and quality has been greatly increased.

## Project Implementation

Products	Specifications
<b>ADAM-5550KW</b>	8-slot Micro PAC with GX2 CPU
<b>ADAM-5017H</b>	8-ch High-speed Analog Input Module
<b>ADAM-5024</b>	4-ch Analog Output Module
<b>ADAM-5051S</b>	16-ch Digital Input Module
<b>ADAM-5056S</b>	16-ch Digital Output Module
<b>ADAM-5240</b>	4-axis Stepping/Pulse-type Servo Motor Control Module
<b>FPM-3121G</b>	12.1" Industrial Monitor with Resistive Touchscreen, Direct VGA, DVI and Wide Operating Temperature

## System Diagram

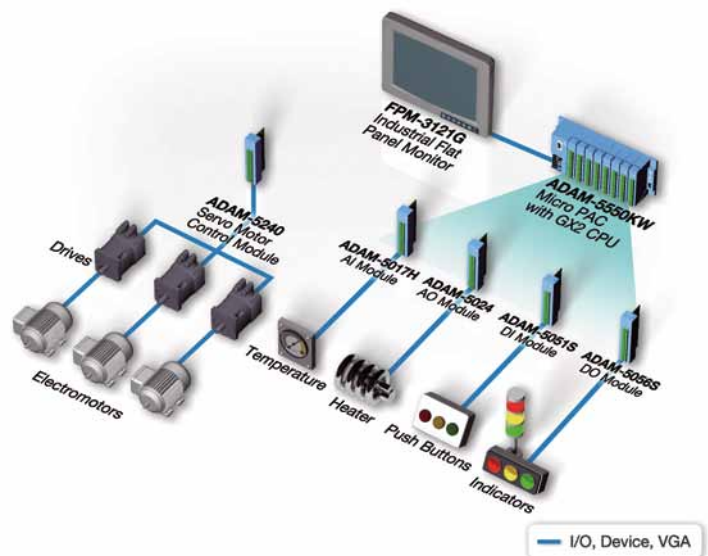

# Multi-axis Ceramic Resistor Test Machine

China



## Introduction

In the global electronics manufacturing market, multi-axis ceramic resistor test machines are widely used for quality testing and screening of micro-electronic components. Supported by various programs, these systems can realize diverse signals and integrate a wide range of functions and devices with real-time control such as motion, HMI and advanced testing instruments. The system highlighted in this application was created by Advantech to support dynamic displays and self-diagnostic functions. This combination of features has helped improve the system, increasing production efficiency and quality.

## System Requirements

Ceramic resistor test machines are required to support multi-axis synchronized motion control and a large amount of digital control. This client also wanted to integrate GPIB instruments, high-end test instruments and an HMI device. The goal was to create an advanced testing control platform with diverse signal reading, a variety of integrated functions and real-time control. The system also required efficient and real-time development software.

## System Description

Integrated with multi-axis motion control, digital status monitoring, GPIB communication instruments and a touchscreen, the system achieves real-time control and multi-axis motion and digital instrument control. Advantech's IPPC-4000D allows users to easily edit, modify and save data.

The system allows electronic components to be easily tested quickly and thoroughly to satisfy production needs. The system integrates visual inspection capabilities through the USB connector on the PC, which, combined with its high speed computing capabilities, also makes quality diagnostic tests. Equipped with Advantech's powerful controller, diversified control cards and rich communication interfaces, the system controls various equipments, such as buttons, signals, instruments, drive motors, and more.

## Project Implementation

Products	Specifications
<b>FPM-3121G</b>	12.1" Industrial Monitor with Resistive Touchscreen, Direct VGA, DVI and Wide Operating Temperature
<b>IPPC-4000D</b>	5.7" VGA TFT LCD 4U 19" Rack Industrial Panel PC with 7 Expansion Slots
<b>PCI-1240U</b>	4-axis Stepping and Servo Motor Control Universal PCI Card
<b>PCI-1756</b>	64-ch Isolated Digital I/O PCI Card
<b>PCI-1671UP</b>	IEEE-488.2 Interface Low Profile Universal PCI Card

## Conclusion

Through Advantech's advanced PC with integrated control and communication modules, the system not only realizes real-time communication between the system and external measuring instruments, but also increases system response times and production precision.

## System Diagram

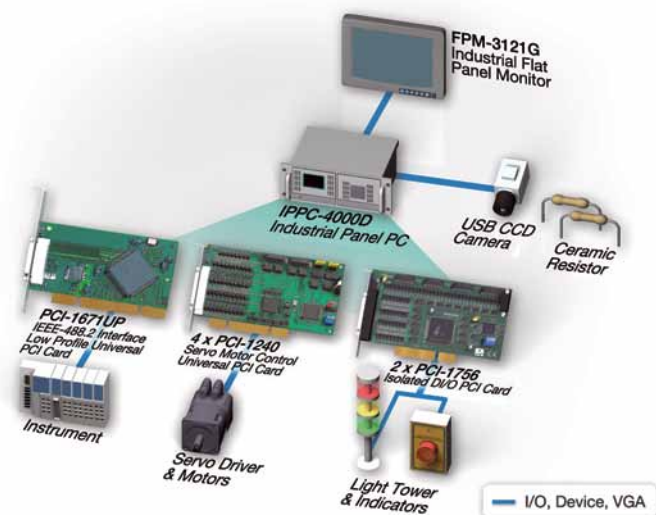





# Steel Factory Control & Monitoring System

Taiwan



## Introduction

In the past, relay devices were the main components for industrial automation control systems, and some existing DA&C factories still use them today. But in today's complicated systems, relays provide limited use, poor flexibility and unreliable stability. Moreover, they are not easily maintained, the control panel is big and heavy, and is not easy to move. With the advent of PLC & PC-based control systems, new systems can easily benefit from easy configuration, high flexibility and high stability. One steel factory was looking to upgrade their system with a new PLC-based control system with a redundant Ethernet network.

## System Requirements

This steel factory was using the very traditional relay devices as control system. It was with big volume control panels. The system was using the complicated physical wiring so that is very difficult for maintenance work. In order to consider the stability and functionality for future operation, it is necessary to go for the revamping work for the old control system. Users had considered the PLC or PC-based control system. But due to the steel factory is with lots of the environment and facility management requirements, the high computing capability and cost effective analog I/O expansion would be more suitable than PLC system.

## System Description

Considering most system engineers are familiar in PLC programming, the ADAM-5550KW with embedded KW SoftLogic was the most suitable choice as the control system. But the system integrators were very worried about the integration capabilities and the system stability, so a reliable network infrastructure was crucial as well. The EKI-7659C Managed Ethernet Switch was chosen to establish a redundant ring between the controllers and information layer. The X-Ring redundant architecture allows one switch in the ring to be the Primary Ring Master. One path of the Ring Master is the forwarding path, while the other is the backup path. If one links fails, the Primary Ring Master automatically activates the backup path within 10ms.

## Project Implementation

Products	Specifications
<b>ADAM-5550KW</b>	8-slot Micro PAC with GX2 CPU
<b>ADAM-5000/TCP</b>	8-slot Distributed DA&C System for Ethernet
<b>ADAM-5051</b>	16-ch Digital Input Module
<b>ADAM-5069</b>	8-ch Power Relay Output Module with LED
<b>ADAM-5080</b>	4-ch Counter/Frequency Module
<b>EKI-7659C</b>	8+2G Combo Port Gigabit Managed Redundant Industrial Ethernet Switch

## Conclusion

Given the scope and functionality required to fulfill this project, Advantech's integrated offering provided the ideal solution. Not only is the new control system smaller, cheaper to maintain and easier to program, it is also much more efficient and reliable as well. Moreover the new network not only provides a dependable infrastructure, but also redundancy, guaranteeing the steel factory's operations will always be online.

## System Diagram

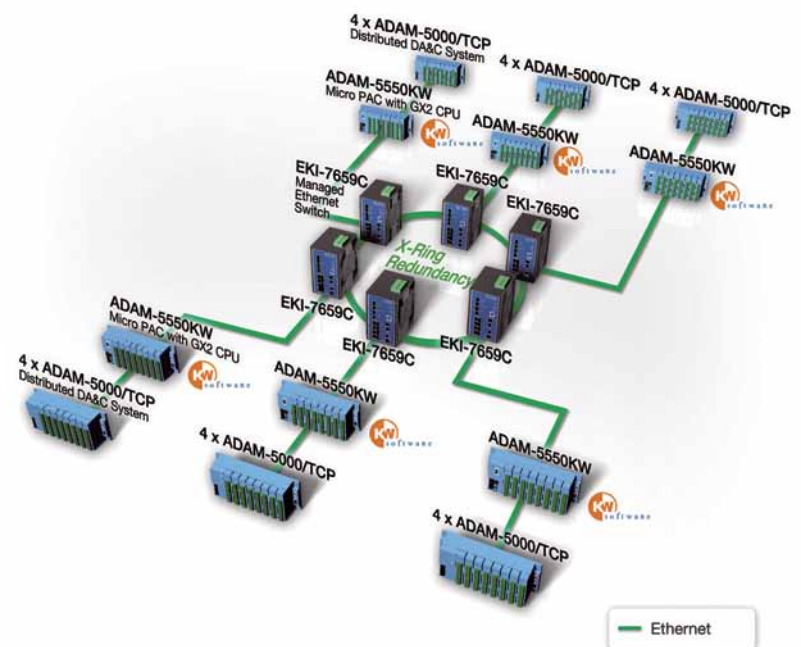



# Jet Engine Test System

China

## Introduction

Jet engine testing is a complicated and tricky process. Due to the expensive costs of fuel and materials, the tests need to be implemented quickly with high sampling speeds and precision. Large-sized engines need to be mounted on an engineering vehicle for field tests. In these scenarios the system has to be shock-proof and interference resistant in order to ensure safe and reliable test results.

## System Requirements

The jet engine testing application required high sampling speed and high sampling frequency. The devices applied must be shock-proof and interference resistant to be suitable for various engine tests. They must also follow standard communication protocol for convenient program modifications and updates.

## System Description

Jet engines should be tested strictly at the test facility before being put into production. Under controlled conditions, data is gathered from the sensors then transmitted to an industrial computer in the field site, and finally measured and verified in the control room.

Advantech's analog input module, PCM-3813I, is used for monitoring data which is changing continuously, such as fuel flow, pressure and temperatures. The digital input/output module, PCM-3730I, is used for controlling actions, such as failure alarms, interlock control and emergency shutdown. It can be mounted directly on an engineering vehicle for field measurements. In between, the communication module with isolation protection, PCM-3610, is used to connect computing platforms via RS-232/422/485.

Installed at both the field site and control central site, the PCM-3725 ensures digital I/O control will work properly during test procedures while the relay function can activate an alarm in the event of a defect or error during testing. All signals sampled during the testing can be transferred to the central computer via standard PC/104 or PCI-104 interface.

## Project Implementation

Products	Specifications
<b>PCM-3813I</b>	100 kS/s, 12-bit, 32-ch Isolated Analog Input PCI-104 Module
<b>PCM-3730I</b>	32-ch Isolated Digital I/O PCI-104 Module
<b>PCM-3725</b>	8-ch Relay and Isolated Digital Input PC/104 Module
<b>PCM-3610</b>	2-port RS-232/422/485 PC/104 Module with Isolation Protection

## Conclusion

In order to resist the extreme vibrations and heat during jet engine testing, the systems at the test facility are required to be extremely robust. These modules need to support multi-channel/optical isolation communication with fast data sampling and high precision via standard PC/104 interface. Advantech's rugged I/O modules proved the perfect solution with shock-proof designs and superior interference resistance. With standard driver programs and measuring software, our customers can develop programs by themselves or easily update the testing software based on different requirements.

## System Diagram

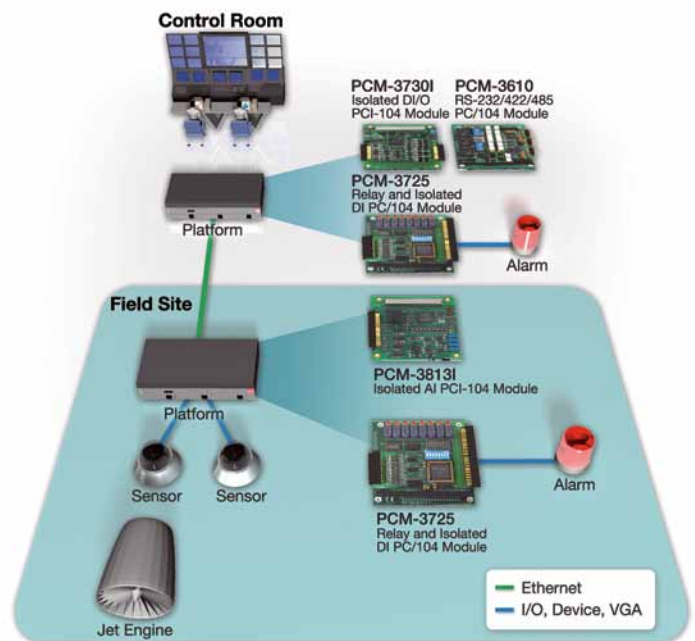

# LED Die Bonding Solution

China



## Introduction

As part of the global green-energy initiative, energy saving LEDs are being increasingly applied worldwide in lighting, traffic, and consumer electronic applications. These applications are creating a high demand for automatic LED manufacturing machines that meet balance of performance, cost and reliability. The quality of LED die bonding relies on excellent collaboration between machinery vision and motion control with microsecond precision that demands for high computing capability.

## System Requirements

Our customer is an LED die-bonding manufacturer that is gaining an increasing market share in China. Many years ago they adopted a PC-based video inspection system with a set of PLCs for motion control and signal monitoring. However, challenges remained for the twofold system to achieve synchronized communication; and the skewed motion resulted in inaccurate placement and high defective rates. Therefore, they were looking to build a new system that incorporates high-resolution video inspection and 10-12 axes motion control, provides a PC-based dual core system with high performance, enables greater precision and speed of die attachment and ensures faster, more precise and reliable machinery vision.

## System Description

This solution is comprised of two systems working together. A mid-range system designed to create quality LEDs for high-end applications driven by servo and stepping motors, which allows for data feedback and greater precision, and a economic system designed to create standard LEDs driven only by stepping motors. Each system is built with Advantech's dual-core UNO-3084 as the IPC platform, allowing PCIe or PCI cards installation for pick & place motion, analog I/O and digital I/O. Its two onboard IEEE 1394b ports also allow one or two CCD cameras to capture images and carry out synchronized signal digitalization for machine vision inspections. The project also includes one 15" TFT LCD monitor with touchscreen for each system as the human-machine interface to show the status of the LED die bonding machine.

Both systems also adopt the PCI-1751, a digital input/output and 2-ch counter PCI card, which is in charge of digitizing data, monitoring status and motion counter feedback. For the mid-range system they adopted three PCI-1240U, 4-axis stepping and servo motor control cards, having 2/3-axis linear, 2-axis circular and continuous interpolation functions to handle complicated and precise motion control. The economic system adopts two PCI-1245E, economic 4-axis stepping and servo motor control cards with 2-axis linear interpolation with point-to-point function. It also includes the PCI-1243U, a 4-axis stepping motor control card for process in and process out control for simpler motion control applications.

## Conclusion

Advantech is able to provide products that can be selectively combined into low-to-mid end or high end solutions that meet the best balance between performance and cost and can be used in various forms of micro-electronic component assembly. Advantech also boasts a unique capability in providing costume-tailored total solutions for our customers. For LED die-bonders we provide packaged solutions, including IPCs, PCI cards, motors, monitors, video cameras and associated software that have been fully tested before delivery.

## Project Implementation

Products	Specifications
PCI-1751	48-ch Digital I/O and 3-ch Counter PCI Card
PCI-1240U	4-axis Stepping/ Pulse-type Servo Motor Control Card
PCI-1243U	4-axis Stepping/ Motor Control Universal PCI Card
PCI-1245E	Economic DSP-based 4-axis Stepping and Servo Motor Control Universal PCI Card
UNO-3084	Intel® Core™ 2 Duo Automation Computer with up to 4 Expansion Slots for PCI Express or PCI Support

## System Diagram

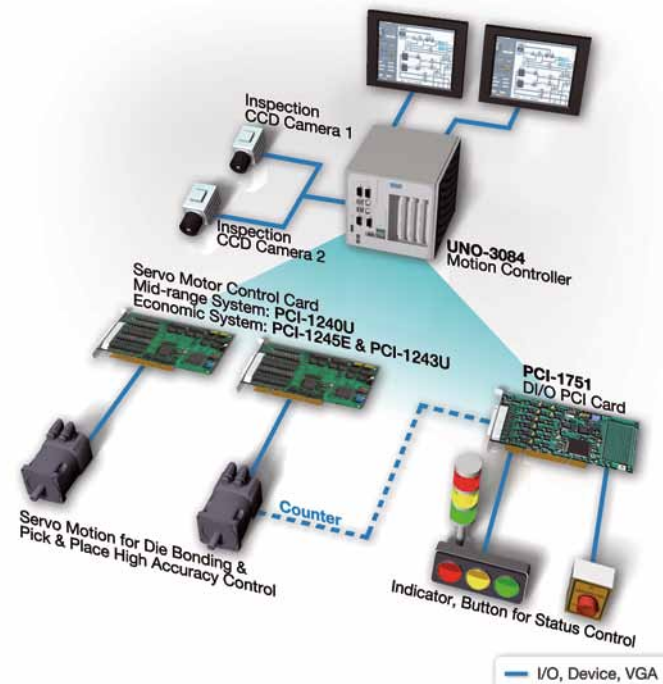



# Ethernet Switches for an Automotive Production Line

China

## Introduction

China's thriving car market is nurturing a huge local automotive manufacturing industry, with a total of 18 million cars made in China during 2010, which presents 30% year-over-year growth. Advantech's customer is a system integrator providing solutions for automatic production control and management to China's top motor manufacturers. They focus on production lines of driveline parts including gearboxes and engines.

## System Requirements

Solutions for Executive & Management Systems (EMS) and Assembly Management Systems (AMS) for motor manufacturers and parts producers require the support of automatic control and information technologies to achieve real time production monitoring, equipment processing parameter setting, product quality management, data archiving & backup and remote user management.

A solid and reliable communication network is critical for carrying out all these functions. To ensure dependability, the network must be designed to take into account the necessary level of redundancy including: a self-healing X-Ring of Ethernet managed switches, which provides a redundant network path in the event of a failure on the network or similar problem; also required is a redundant power supply to provide backup in-case of a catastrophic power failure.

## System Description

Our customer's solution for motor driveline workshops consists of a device level, a control level and an information level, which communicate via a fiber optic network.

The backbone of the network is supported by Advantech's industrial managed Ethernet switches of EKI-7659C or EKI-7656C, which support Advantech's proprietary redundant network protocol; X-Ring that provides users with an easy way to establish a redundant Ethernet network with ultra high-speed recovery time of less than 10ms.

The EKI-7659C/EKI-7656C also come with a wide variety of ports and support the unusual function of "port trunking", that is, the grouping of two or more ports together and working as a logical path to increase bandwidth between two cascaded switches.

At the lowest level, a number of Advantech's EKI-2528 or EKI-2525 switches are deployed to connect with Programmable Logic Controllers (PLCs) which command and control manufacturing equipment. The EKI-2528/EKI-2525 provide redundant power input design, and are secured with a double protection mechanism: Power Polarity Reverse Protect and an Overload Current Resettable Fuse. The former tolerates reverse power wiring and the latter secures the system from overload currents.

The upper level of the application architecture-the information system for the supervisors is supported by EKI-6311GN, a wireless AP that provides a reliable wireless environment for industrial building systems to allow for remote real time monitoring over the production lines.

## Conclusion

Advantech's Managed and Unmanaged Ethernet switches used in this application provide optimum network performance and security. After our customer substituted their original switches with Advantech Ethernet switch and wireless AP products, they found the switches are compatible with different brands of PLCs, and the whole system still operates correctly. By using Advantech products they've saved money without sacrificing system performance.

## Project Implementation

Products	Specifications
EKI-7659C	8+2G Combo Port Gigabit Managed Redundant Industrial Ethernet Switch
EKI-7656C	16+2G Combo Port Gigabit Managed Redundant Industrial Ethernet Switch
EKI-2528	8-port Unmanaged Industrial Ethernet Switch
EKI-2525	5-port Unmanaged Industrial Ethernet Switch
EKI-6311GN	IEEE 802.11 b/g/n Wireless Access Point/ Client Bridge

## System Diagram

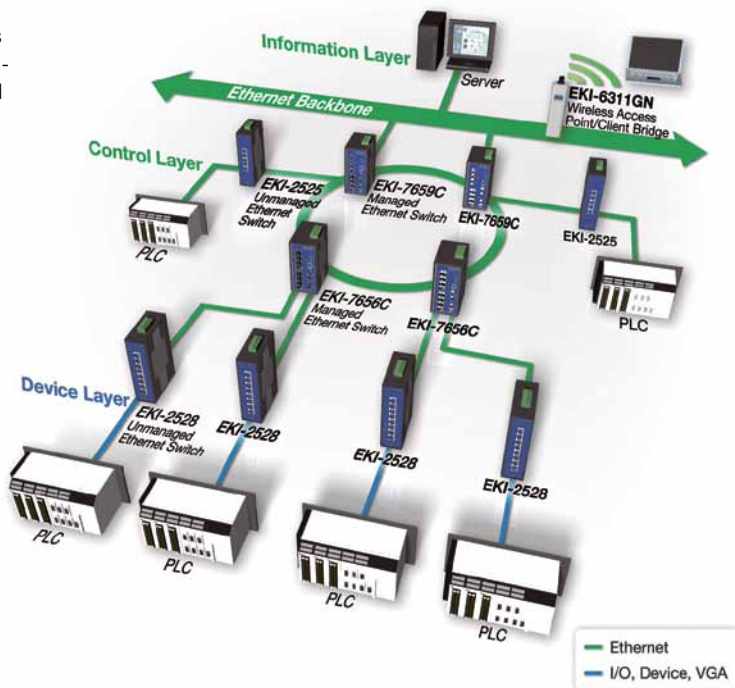

# A Tobacco Production Automation System for Controlling and Monitoring Tobacco Plants

China



## Introduction

Without the aid of computers, calculating production volume in a tobacco plant is troublesome and error-prone. PC-based monitoring systems that automatically collect production data and keep records can greatly improve in-factory logistics management and machinery maintenance. Our customer is a branded tobacco producer in China. When they came to Advantech, their production lines were already automated with the deployment of Programmable Logic Controllers (PLCs). However, they were still dependent on manual labor to count the amount of cigarettes and other materials, and to check and record the data-logs stored in the PLCs for repair and maintenance analysis. But with Advantech's PC-based monitoring machines, installed next to manufacturing machines, related data is shown on touch screens and transmitted to the control center, helping to reduce errors and improve management efficiency.

## System Requirements

A tobacco plant is a complicated environment with a variety of manufacturing machines, including tobacco shredding machines, drying machines, cigarette making machines, and packing machines. Throughout the plant, there are also a wide range of temperatures and voltages used; thus, the industrial computers (IPC) applied must be robust and reliable. Additionally, the IPCs need to have PCI expansion slots for inserting cards to link with legacy PLCs at the production lines. Because the monitoring system has to collect and transmit large amounts of data, powerful CPUs for the IPCs and rapid and reliable Ethernet are required.

## System Description

The monitoring machines provided by Advantech to this tobacco plant are stand-alone machines specially designed for this customer. Each of the machines contains a fanless industrial computer (UNO-3282) inside and a 19" TFT LCD touch screen (FPM-3191G) as a front panel human-machine interface (HMI). The FPM-3191G with stainless steel chassis and NEMA4/IP65 compliant aluminum front panel provides reliable functionality in the harsh and dusty environments.

Additionally, the UNO-3282 is a high-performance automation computer with a powerful Intel Core 2 Duo processor. Its expansion capability, a choice of two PCI expansion slots or one PCIe plus one PCI slots, provides connection to the device level PLCs. The UNO-3282 also has dual teaming-capable gigabit LAN Ethernet ports linking to an Ethernet network with the monitoring machines, and battery-backup SRAM to ensure the consistency of Ethernet networking and data transmissions even in the event of Ethernet breakdown or power breakdown.

At the device level, tobacco manufacturing machines and PLCs are connected using the PROFIBUS protocol. The UNO-3282 then collects data from these PLCs and transmits the data up to central control room. The data is also shown on the FPM-3191G monitor, which allows the operators in the plant to easily read information displayed on the screen and give orders with a touch of their fingers.

## Conclusion

With the use of this monitoring system, all data related to production and machine operation can be shown on terminals and stored on the database in real time, including: the amount of cigarettes produced, defect rate, and the status of PLCs. It saves using manual labor for cigarette counting, and reduces maintenance work for engineers. More importantly, it improves the efficiency of in-factory logistics and the overall management of the factory.

## Project Implementation

Products	Specifications
FPM-3191G	19" SXGA Industrial Monitor with Resistive Touchscreen, Direct-VGA and DVI Ports
UNO-3282	Intel® Core™ 2 Duo M Automation Computer with PCI/PCIe, 2 x GbE, 4 x COM, and DVI Ports

## System Diagram

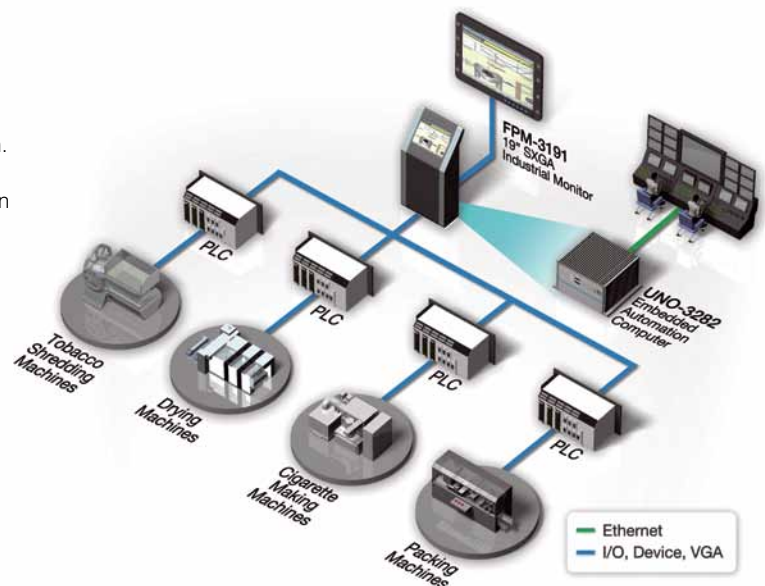



# Touch Panel Linearity Test Solution

China

## Introduction

Thanks to the popularity of smart phones and tablet PCs, the rising demand of touch panels is driving machinery requirements which need higher precision and stability in their manufacturing process. As widely used in panel manufacturing, the linearity testing machine requires simulating the movement of fingers on the panel test. As a result, motion control and data acquisition play important roles in the testing process. However, the traditional Programmable Logic Controller (PLC) operation is limited, the more axes that are required, the more CPU loading is increased, so a PC-based system without such limitations can better meet market needs.

## System Requirements

Our customer is a test equipment vendor, whose linearity testing machine requires high-precision motion control and data acquisition. Through the sliding and pressing movement across the panel's surface to confirm the quality, the testing machine needs a device with a PC's features to deal with a large number of graphical computing functions and data storage.

Meanwhile, in order to avoid plant shutdown, the product must provide fast and long-term maintenance services. Product compatibility is another issue. Advantech's comprehensive product lines can supply the computers, controllers, drivers and other necessities, so there is no need to use products from different vendors which would easily cause the incompatible problem.

## System Description

With the trend for miniaturization, Advantech's IPC-6608/IPC-6606 is a vertical industrial computer designed for limited spaces. It also includes a fast recovery feature, which is an essential function of plant equipment, and can restore the system, after a crash or interruption, in the shortest time.

In addition, the PCI-1710U data acquisition card with 0.005V high-resolution can measure weak signals. When the machine is performing stress tests, the PCI-1710U will collect the pressure data to ensure normal operation. Its utility offers simplified settings to save customer's development time. Furthermore, Advantech's PCI-1240U motion control card can output the motion control signal up to 4 million times per second and features the 2 to 3 axis linear interpolation and 2-axis circular interpolation, so as to accurately execute the motion control without increasing system loading and a waste of system resources.

## Project Implementation

Products	Specifications
IPC-6608/ IPC-6606	8/6-Slot Desktop/Wallmount Chassis with PS/2 and Redundant Power Supply Options
PCI-1710U	100 kS/s, 12-bit, 16-ch Universal PCI Multifunction Card
PCI-1730U	32-ch Isolated Digital I/O Universal PCI Card
PCI-1240U	4-axis Stepping and Servo Motor Control Universal PCI Card

## Conclusion

Advantech's integrated motion control and data acquisition solution satisfies the special needs of touch panel equipment manufacturers. In terms of product compatibility, limited space equipment, troubleshooting, and even after-sales service, Advantech provides the best quality service and guarantee. In addition, Advantech's global service network makes our products and services more reliable as well as reducing customer's maintenance costs without interrupting plant operations.

## System Diagram

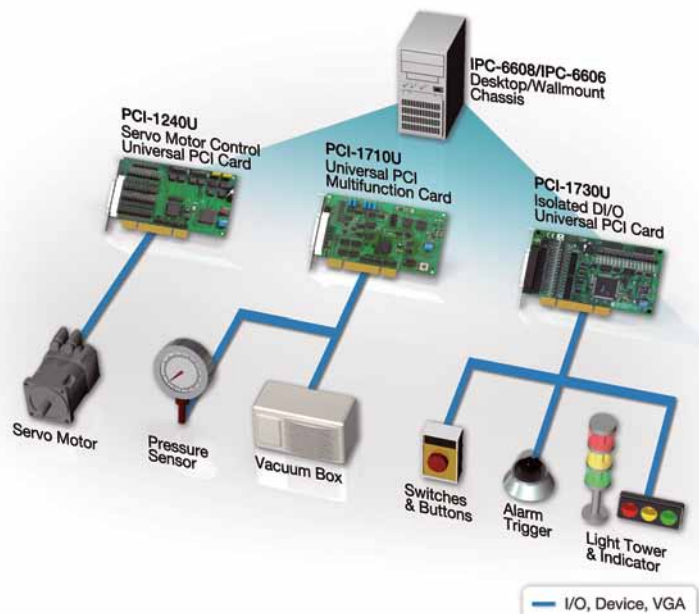

# Solar Cell Test Solution

China



## Introduction

With a global increase in the demand for green energy solutions, the use of solar cells (aka solar panels) is quickly spreading to residential and commercial facilities, resulting in an increase demand in manufacturing and production equipment. The essential steps in the production process of a solar panel include: pick-and-place, high-speed movement, accurate positioning and fixed plug-in fitting. But it is the dislocation and false welding of components that are greater obstacles in the inspection procedure. Therefore, customers need to adopt high-speed multi-axis motion control with a machine vision system to improve their production efficiency.

## System Requirements

Through the use of pick-and-place technology, the solar cell will be placed on conveyer belt and then put in the pre-setting device or storage box where a sensor detects the cell. This traditional procedure is a closed control structure with complex tools for programming and involves a lot of time and money if it needs to change the process or expand the interfaces. In addition, the maintenance costs are far higher than PC-based control systems that lead to low productivity and high production costs. As technology advances, building a flexible PC-based motion control system becomes a primary consideration of many companies since, by using a variety of technologies, including high-speed motion control modules to accurately execute pick-and-place tasks and put the known good cell into the cassette, and also digital input / output modules to acquire the sensors' signals on the conveyor belt and detect the cell's location and surrounding states.

## System Description

The UNO-3084 dual-core embedded controller - integrated with a PCI-1202U AMONet communications card - can provide real-time control device for a pick-and-place mechanism with 20 Mbps transfer rate (scan 1024 digital I/O channel within 1.04ms or manage up to 256 axes for motion control). The AMAX-2752SY/2754SY/2756SY digital control module can deliver the devices' I/O control signal to the control center via AMONet communication. As a control medium between devices and control center, the AMAX series support immediate transmission which not only transmits the production states but also receives instructions from the control center to adjust and precisely control the operation.

## Project Implementation

Products	Specifications
<b>AMAX-2241/PMA</b>	4-axis AMONet RS-485 Motion Slave Module for Panasonic Minas A
<b>AMAX-2752SY</b>	32-ch Isolated Digital Input Slave Module
<b>AMAX-2754SY</b>	32-ch Isolated Digital Output Slave Module
<b>AMAX-2756SY</b>	16/16-ch Isolated Digital Input/ Output Slave Module
<b>PCI-1202U</b>	2-port AMONet RS-485 PCI Master Card
<b>UNO-3084</b>	Intel® Core™ 2 Duo Automation Computer with Dual DVI, 1 x PCIe, 3 x PCI and FireWire

## Conclusion

Using PC-based AMONet solution, the integration of UNO-3084, PCI-1202 AMONet and AMAX series, the process can be divided into multiple areas for effective control. Meanwhile, the whole system can lessen the wiring installation time of electromechanical systems, improving performance, decreasing error rates and reducing costs. The operator can more easily transform and upgrade the production process. Advantech's AMONet solution also can be integrated with MES or CIM systems. In addition, it reduces the problem of signal attenuation due to longer electrical wiring, and lessens the assembly time and wiring check to improve the time effectiveness of equipment assembly.

## System Diagram

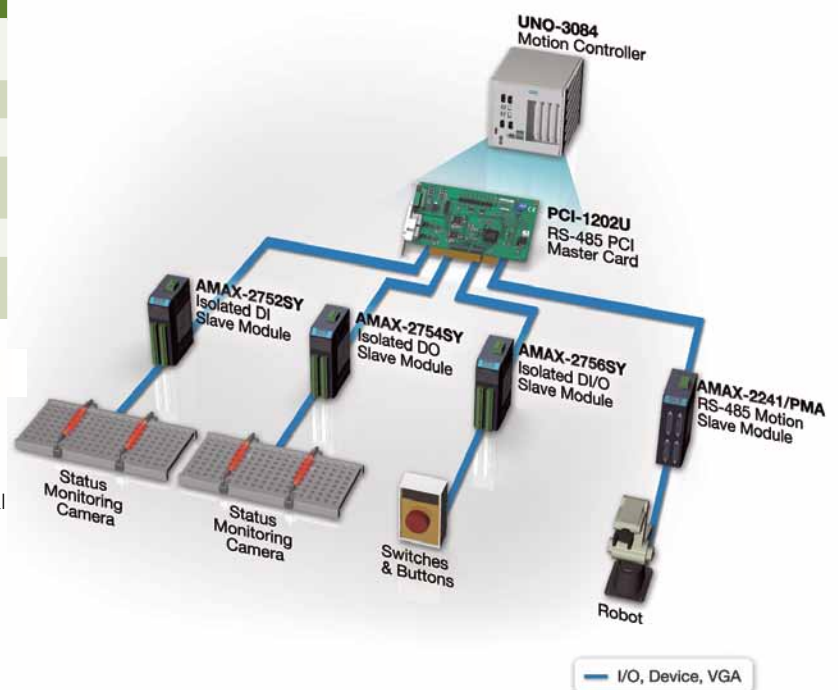

# Intelligent Transportation System

## Solutions for Transportation Automation and Infrastructure

Transportation systems aim at providing communications and technology that allow safe, convenient, comfortable, efficient, and environmentally friendly travel for all commuters. Many cities worldwide are in the midst of improving their transportation system infrastructures, and Advantech is there to provide a helping hand by providing advanced product solutions for the transportation market. Advantech offers cost-effective solutions for traffic monitoring system for railway (station, onboard train, wayside control), freeway (dynamic weighing, tunnel monitoring, passenger information display, entrance control, electronic payment), and other transportation applications.



### Railway Stations

The rapid acceptance of Ethernet-based networking in railway infrastructures is providing many subtle benefits to traveler's worldwide. Train station applications cover fire alarm systems (FAS), automatic fare collections (AFC), passenger information systems (PIS), and control room.



### Onboard Train and Rolling Stock

Today's train information systems are the key communication link between transportation operators and the traveling public. Onboard train applications cover driver control, passenger information systems (PIS), in-seat video entertainment systems, and IP surveillance.



### Freeway Management and Information Display

Freeway management programs support and promote the use of integrated and coordinated systems to provide proactive freeway management that improves the safety efficiency and reliability of travel on freeways and highways worldwide.



### Electronic Payment

Electronic payment systems are very public and the major key is in providing reliable collection systems. Advantech's solution is targeted at simplifying payment for customers and helping reduce congestion at the exits to parking facilities and toll booths.

## Product Solutions

### HMI



**TPC-1250H**  
12" Touch Panel PC

### Communications



**EKI-6340**  
Wi-Fi Mesh AP



**EKI-1526**  
Serial Device Server



**EKI-6558TI**  
EN50155 Switch

### Controllers



**UNO-2173AF**  
Energy Efficient Automation Computer



**APAX-5520**  
Programmable Automation Controller

### I/O



**PEC-3710**  
Integrated I/O Controller



**ADAM-4000/  
ADAM-6000**  
Remote I/O Modules



# Passenger Information Display System (PIDS)

Taiwan



## Introduction

For all mass transportation systems, efficiently communicating important information to all passengers is very important. Arrival times, departure times and weather conditions are all vital subjects, and to transmit such real-time data, the system must have a reliable backbone. By adopting Advantech's fast dual-LAN serial communication products as the core of their display solution, Taipei's Mass Rapid Transit system can now control and transmit real-time information from the control center to all local stations, providing accurate, valuable data to all passengers.

## System Requirements

As in other international cities, Taipei has been experiencing tremendous growth, putting a strain on both personal and public transportation. This growth convinced Taiwan to further develop their Mass Rapid Transit (MRT) system in Taipei and they contacted a handful of the top automation companies to provide solutions for this new system. After a preliminary period, Advantech was chosen to develop the Passenger Information Display System (PIDS) as real world testing proved its products were faster and more reliable than any of its competitors.

The system they were seeking to develop included the following requirements:

- Integrates a control center, factory and multiple MRT stations together with one reliable network transmission system
- Reduces data loss to the smallest amount possible, while increasing both speed and reliability
- Real-time data transmission capabilities
- Keeps the solution as cost-effective as possible

## System Description

The Passenger Information Display System is set up in the central control center to monitor and control all of the devices in the local MRT stations. Each local site also has its own PC to link back to the PIDS at the central room for local control and emergency use. Each local PC can monitor and control the all of the PIDS devices in its own station, allowing the staff to control the flow of information on the PIDS board at each platform.

The MRT communication system conforms to the PCM transmission architecture of CCITT PCM-30, which allows them to connect to the operation center, machine factory and each station. These communications can include voice, digital data, signals, and warning messages. In order to reduce the noise interference of the high power use (750 V<sub>DC</sub>) within each train station, the PCM system uses a single fiber optic architecture to link the operation center, machine factory and all of the stations. To ensure accurate information can be transmitted to the PIDS board without any data loss, the MRT system adopted Advantech's fast EKI-2741F fiber optic converter, EKI-2528 unmanaged Ethernet switch, and high throughput EKI-1526 Serial Device Server.

## Conclusion

This solution allows Taipei's MRT system to control and transmit real-time information from its control center to all local stations, providing the entire commuting city of Taipei with accurate, travel information, (including regular train status, banner propagation, and emergency information) to improve travel efficiency, safety and ease.

## Project Implementation

Products	Specifications
EKI-1526	16-port RS-232/422/485 Serial Device Server
EKI-2741F	10/100/1000TX to SFP Type Fiber Optic Gigabit Industrial Media Converter
EKI-2528	8-port Unmanaged Industrial Ethernet Switch

## System Diagram

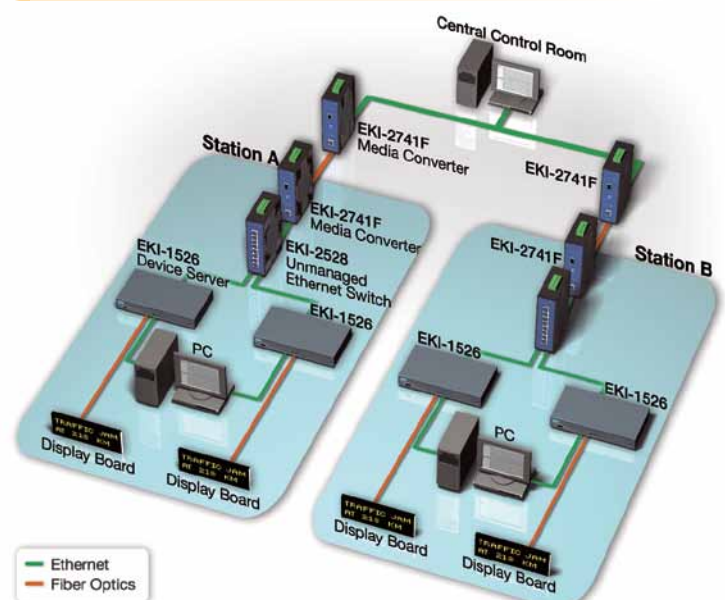



# Fiber Optic Train Station Communication System

Indonesia

## Introduction

A train station in Indonesia wanted to upgrade its network backbone to fiber optics for data transmission. Compounding the issue was the fact they wanted to keep their current RS-485-based PLC for the railroad crossing gates and crossing signs as the controller due to budgetary concerns. Since RS-485 is widely accepted as the standard interface for PLCs, this customer was confronted with the difficulty of finding a way to implement a fiber optic interface with their existing PLC system, and turned to Advantech for support.

## System Requirements

The customer was looking to implement a fiber optic based system with their RS-485-based PLC as the control unit. They also had the following additional requirements:

- The solution should be cost-effective
- The control room is far away from the train stations, so long distance transmissions are required with isolation protection to ensure reliable communications
- Single-mode fiber optic communications

## System Description

The existing PLC system controls the railroad crossing gates and crossing signs. To allow for fiber optic connectivity, Advantech installed a bi-directional converter, ADAM-4542+ in each station to allow the PLC to switch from RS-485 to fiber optic, or vice versa. The ADAM-4520I RS-422/485 to RS-232 converter allows data to be transferred between the train stations and central room where the industrial computer is located. Both ADAM-4542+ and ADAM-4520I are capable of transmitting messages over long distances without interference.

## Project Implementation

Products	Specifications
<b>ADAM-4520I</b>	RS-232 to RS-422/485 Converter
<b>ADAM-4542+</b>	Single-mode Fiber Optic to RS-232/422/485 Converter

## Conclusion

With so many communication interfaces in the market, customers sometimes have problems connecting devices. Advantech not only provides a variety of industrial-grade system components but also offers a wide range of converters for customers to connect with existing platform, even many legacy systems. Equipped with these cost-effective and reliable converters, customers no longer need to worry about connections or installation, and can easily realize a high-speed upgrade without a complete overhaul of the system.

## System Diagram

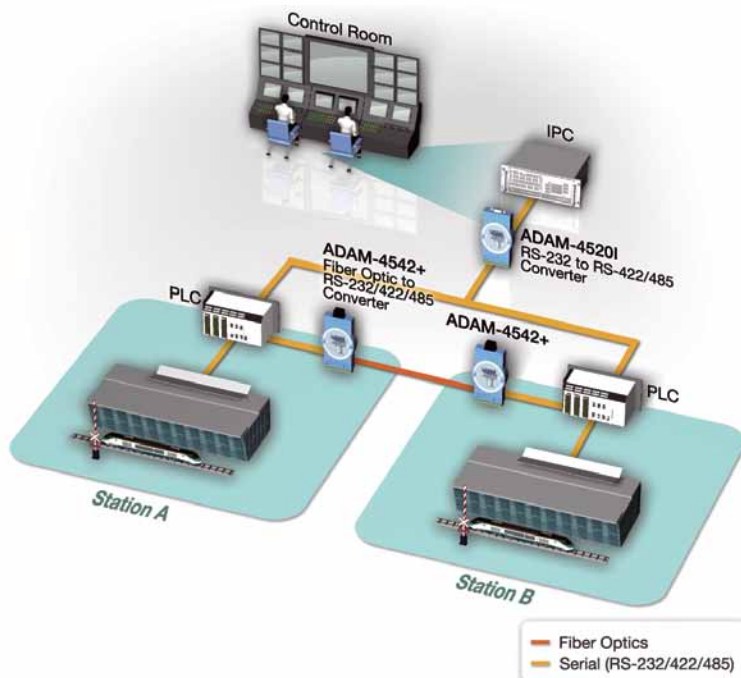

# Automated Circulation System for Railway Transportation

Italy



## Introduction

Rete Ferroviaria Italiana (RFI) is in charge of managing the entire railway infrastructure in Italy. Recently they were concerned with improving circulation control in the face of growing traffic without affecting trip duration. Their target could be reached by creating a completely automated infrastructure to handle traffic in the stations in case of problems with communication in the remote central control room. Without an automated system, train routes must be handled manually, which is very time-consuming.

## System Requirements

Rete Ferroviaria Italiana wanted to introduce intelligent devices able to help remotely manage railway traffic. In case of a lack of communications, the system needed to be able to analyze the input signals and re-route the trains in safe manner. The devices needed to be rugged and reliable, offering versatile functions for their unique application.

## System Description

Advantech's ADAM-5510KW/TCP PAC is placed in every railway station, and along the railway route there are 40 units of ADAM-5510KW/TCPs located at different stations. The PAC is able to acquire all the input signals from the ADAM modules and automatically re-route trains according to pre-defined programming parameters. The system is connected to another room completely independent from the main backbone communication system in order to ensure remote supervision in case of a communication problem. The system is composed of SCADA software in order to control, monitor and drive all the PACs. The SCADA software at the central station acquires field data from the ADAM devices. ADAM-5510KW/TCP is equipped with an ADAM-5055S DI/DO module. The device has been chosen for its form factor that has good computation power allowing high expansion possibility. Advantech system integrator Erreuno integrated SCADA software with to customize the solution.

## Project Implementation

Products	Specifications
ADAM-5510KW/TCP	4-slot SoftLogic Controller with Ethernet
ADAM-5055S	16-ch Isolated Digital I/O Module with LED

## Conclusion

After implementing the new system, RFI was able to realize high voltage isolation on the power supply and serial inputs, with Ethernet connection to the main structure and can now use Modbus TCP/RTU compliancy to ensure reliable communications. Advantech's rugged products were able to provide powerful hardware to ensure local real time DI/DO control capability of stand alone control with possible future local expansion through the ADAM-5000 series. Moreover they achieved a flexible and powerful integrated development suite with KW Multiprog.

## System Diagram

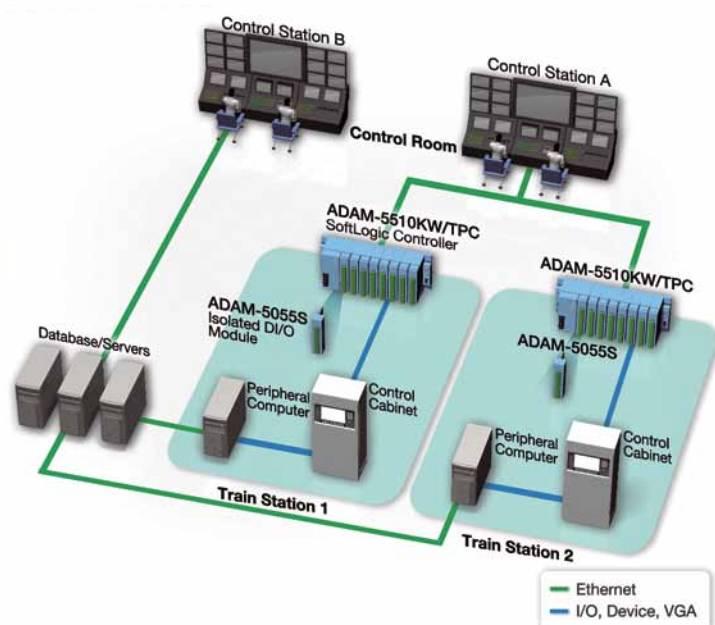



# Surveillance and Monitoring System over Power Substations in Beijing Subway

China

## Introduction

Over the last 10 years, the rapid expansion of Beijing's underground system has helped to modernize the city. However, the sprouting metro lines would be paralyzed if the supply of electrical power was interrupted. In each subway station, near one end of the platform, and sometimes in the basement, is an enclosed structure where equipment for electric power transformation is located. The purpose of these substations is to transform the voltage from the city grid into one that is used by train. In each of the substations, there are meters and other terminal devices monitoring the status of the transformer, the use of power, and environmental factors such as temperature and pressure. This is where Advantech comes in: all this information needs to be collected and carefully monitored using a reliable computer system which can automatically control the system.

## System Requirements

Our products are used in the power substations of one of the Beijing Subway lines. Since the operating environment is full of electromagnetic interference, the computers used for monitoring the equipment must have strong anti-disturbance capabilities and must meet the Chinese government's electrical standards.

Due to their location and the long operating time of the subway, the maintenance of the computers is not an easy job. Thus, the computers deployed here have to be peculiarly reliable and robust. The client also required redundant fiber-optics and a rack mountable computer for the communication network.

## System Description

For this solution, Advantech provided UNO-4672 automation computers, which have 6 LAN ports and 10 isolated COM ports (2 x isolated RS-232 and 8 x isolated RS-232/422/485) that are used to connect to metering equipment and other devices in the substations to collect data, and then transmit the data via Advantech's EKI-7656C Ethernet switch, a redundant fiber-optical managed industrial Ethernet switch with 2 gigabit combo ports and 16 fast Ethernet ports, up to the control center. The proprietary redundant network protocol, the Advantech developed X-Ring provides users with an easy way to establish a redundant Ethernet network with an ultra high-speed recovery time of less than 10 ms. To monitor the substations' activity from a control room, the Advantech IPPC-6172A 17" TFT LCD industrial panel computer was proposed, offering remote out-of-band manageability, improved data transmission and security, and energy efficient performance.

The isolation designs of the UNO-4672, both in terms of power supply and communication interfaces, are especially important for the system to withstand the electromagnetic conditions of substations and maintain stable and reliable operations. The UNO-4672 is not only compliant with IEC 61850-3 and IEEE 1613, the international standards specific to substation automation applications, but also meets the highest level of China's corresponding standards set by China Electric Power Research Institute (Level IV).

## Conclusion

Advantech's UNO-4672, certified with Chinese and international standards for system communications in power substations, is suitable for ultra harsh environmental applications. Together with the EKI-7656C and IPPC-6172A, the UNO-4672 is the excellent choice for subway substation monitoring and surveillance systems.

## Project Implementation

Products	Specifications
EKI-7656C	16+2G Combo Port Gigabit Managed Redundant Industrial Ethernet Switch
IPPC-6172A	17" SXGA TFT LCD Intel® Core™ 2 Quad / Core™ 2 Duo Industrial Panel PC with 2 x PCI Slots
UNO-4672	Intel® Pentium® M/ Celeron® M Automation Computer with 6 x LAN, 10 x isolated COM, 8 x isolated DI, 8 x isolated DO, PC/104+

## System Diagram

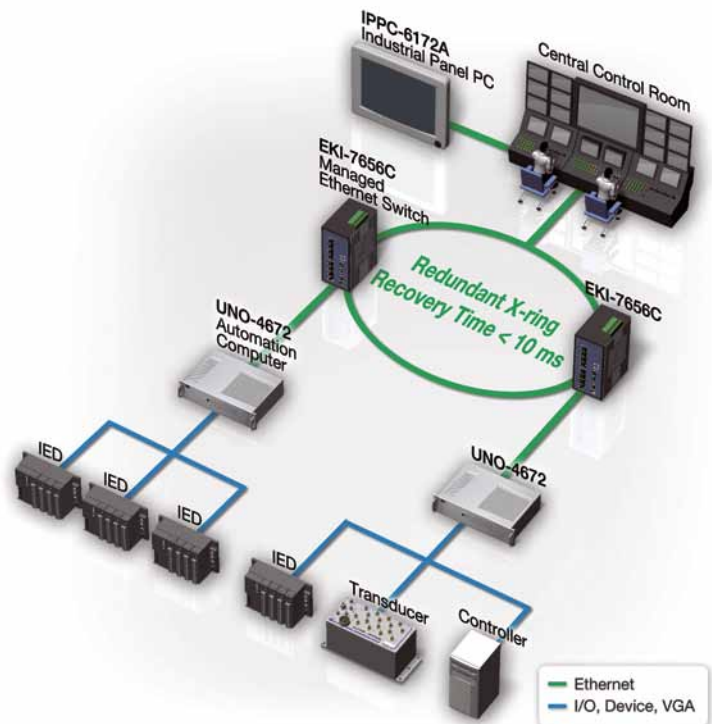

# Parking Lot Monitoring System at Highway Service Area

Japan



## Introduction

Rest areas experience heavy traffic all year long as travelers stop to stretch their legs and visit rest rooms. In Japan, rest areas are called service areas and feature parking lots, restaurants, convenience stores, gas stations, and road information centers in addition to the standard amenities. One of Advantech's customers in Japan was looking to build a high-tech monitoring system at parking lot of a new service area in order to measure traffic flow and provide improved security.

## System Requirements

This project set out to create a comprehensive monitoring system at parking area of the new service area along the Highway in Japan. An extensive communication system would be required to deliver not only accurate parking information to onsite personnel about the coming and going of vehicles, but also to carry traffic information to digital signage to update drivers on the highway status and help provide efficient security at the service area as well.

## System Description

Over 300 Advantech Managed switches, media converters, and SFP modules were applied in this application, from gigabit and fiber optic managed switches and media converters. Advantech's strength in this scenario was the ability to provide a variety of devices that can be easily connected with each other and providing a reliable, redundant network through the X-Ring technology. Many of the devices in this application also feature wide operating temperatures, making them especially suitable for the demanding service area requirements. The switches are connected to controllers for digital signage purposes and IP cameras for surveillance.

## Project Implementation

Products	Specifications
EKI-2541S	10/100T(X) to Single-mode SC Type Fiber Optic Industrial Media Converter
EKI-2748FI	4Gx+4SFP Managed Ethernet Switch with Wide Temperature
EKI-7554SI	4+2 SC Type Fiber Optic Managed Industrial Ethernet Switch
EKI-7659CPI	8+2G Port Gigabit Managed Redundant Industrial PoE Switch
EKI-7656C	16+2G Combo Port Gigabit Managed Redundant Industrial Ethernet Switch
SFP-FXS/LC-30E	100Base-FX Single-mode SFP module
SFP-GLX/LC-10E	1000Base-LX Single-mode SFP module (10 km)

## System Diagram

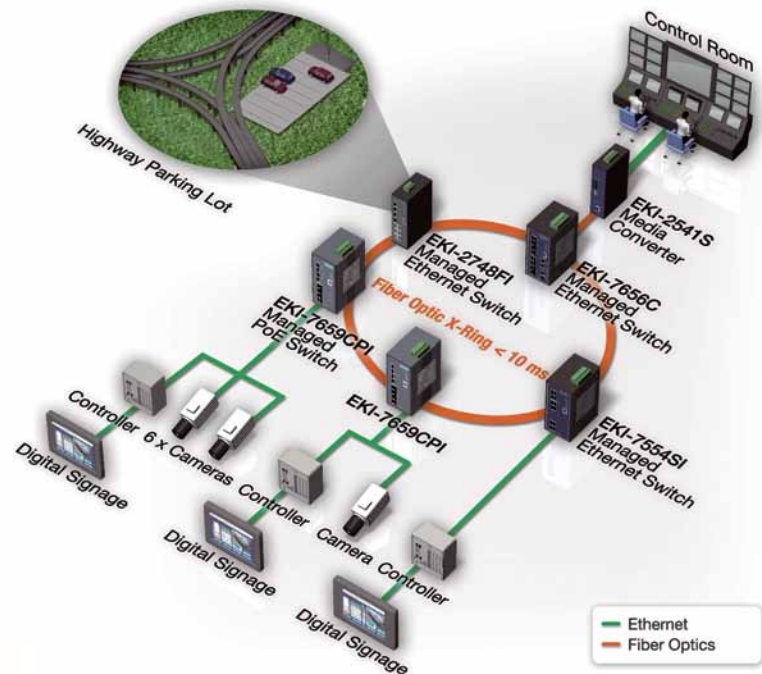

## Conclusion

When the communication system was finished, one of the first comments from the system integrator was how much they appreciated Advantech's ability to provide Ethernet switches, media converters, and rack mount IPCs from one supplier. This allowed them to be assured all products in the communication system would be well integrated with each other with minimal programming effort. In addition, they were very satisfied that Advantech's EKI series of Industrial Communication devices provided them with a reliable, redundant and robust communication system to compliment their new, modern service area.



# Display Panels for Subway Trains

China

## Introduction

China CNR Corporation Limited is not only a major provider of railway vehicles in China's domestic market, but also a main exporter in the world, selling rolling stock and equipment to over 50 countries. In a recent cooperative move with CNR's R&D center, Advantech became Asian first industrial computer manufacturer to initiate its first step into the rolling stock industry by providing a touch panel PC, which serves to be an information display on the train's control mainboard. Computers used for the control system in a moving train need to meet the most rigorous requirements for safety and reliability. This custom-tailored TPC-710D touch panel computer shows control data such as speed, temperature, door and window and other surveillance information to the train's conductor or operators.

## System Requirements

Constant vibration and shock are a fact of life in railway systems; therefore, anti-vibration and anti-shock capabilities are a must for any rolling stock application. Waterproofing and more robust & reliable connectors are crucial for rolling stock computers to resist vibration and shock and guaranteeing safety and reliability, therefore M12 or M16 connectors are necessary for on-board use. The variable temperatures that rolling stock operates under mean that all computers must have a wide range of temperature acceptance. Sudden surges in voltage from the starting and stopping of the train provide unusual challenges; therefore, all equipment must have a wider power input tolerance range. Fanless design is also important for an industrial computer used in the rugged environment of rolling stock, as it reduces dust that may cause the system to fail.

## System Description

The Advantech TPC-710D is a custom-made touch panel computer designed to meet all the demands of rolling stock applications. With a 10.4" high-resolution color display, it is an embedded part of the control mainboard and shows vehicle control information to the train's conductor or operators. To ensure stability and reliability, the display computer is panel-mounted with locking screws, and uses a stainless steel chassis and supportive brackets to increase its robustness.

The TPC-710D is connected to other devices in the system with a variety of interfaces, including serial and LAN ports and a port for connecting power. All these ports are located in the back of the computer. This not only saves space but also aides with waterproofing and connection of the lockable M12 or M16 connectors. It also uses a solid state CompactFlash card to store information, including the operating system, thereby reducing the impact of vibration and shock. Its fanless design ensures a dustless environment and reduces the chance of failure during the long operating time.

## Conclusion

For any monitoring display to be used in metro subway trains, the screen has to be continually on for 18 hours a day. It has to be particularly robust, standing up to the rigors of rail operations. Advantech's TPC-710D meets all the demanding requirements of rolling stock applications. Its fanless design, anti-vibration and anti-shock capabilities create safe, reliable and high performance operations in a space-saving form factor.

## Project Implementation

Product	Specification
TPC-710D	10.4" High Resolution Color Touch Panel Computer

## System Diagram

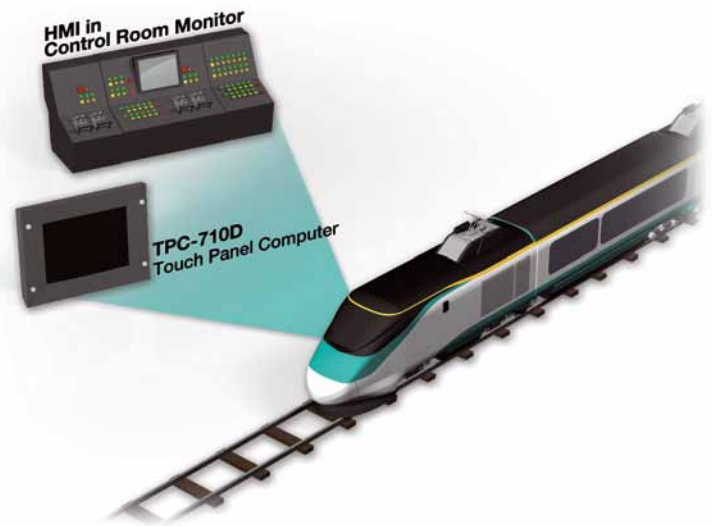

# Dynamic Weighing System

China



## Introduction

With the rapid development of the economy in China, transportation has changed the landscape forever and has caused huge problems with traffic management. In order to facilitate the faster moving of traffic, whilst providing much needed funds for future road development, the authorities set about designing a way of measuring the weight of vehicles whilst they are moving. The system comprises of the following equipment: weighing controllers, weighing sensors, tire inspection sensors, vehicle separators, and coil sensors. When vehicles pass over the dynamic weighing machines, at a limited speed, the system detects the axle's load, car load and type and then sends the information to the computer to calculate the toll based on the actual load.

## System Requirements

The technology of dynamic vehicle weighing has been used in China for many years, but previously, industrial computers or single-board computers were used to acquire and compute the data. In order to achieve the desired functionality, the system needed to use products from different vendors; this in turn created compatibility issues. What was needed was a way of integrating the technologies from multiple vendors.

Environmental and technological changes meant that new low power, anti-interference, compact devices, including high-speed digital-to-analog converter with high identification and sensitivity for the data acquisition were required for this project. The system would use solar cells as its power source; therefore the ideal devices needed to be capable of running on low power, whilst being robust and reliable enough to continue working in all weather conditions.

## System Description

To meet those requirements, Advantech's PEC-3710, an all-in-one low-power computing platform, was specifically designed for dynamic weighing systems in China. Based on Advantech's experience in IPC and data acquisition, the PEC-3710 is a compact integrated I/O controller which combines the CPU, data acquisition, communication functions and storage in one small and robustly built platform to accurately acquire the signal and compute the data. When the car passes through the weighing station, the sensor obtains the weight data and turns that into electrical signals, which are then analyzed by the program at the toll station. The data is transferred from the weigh station to the central control room via RS-485 serial cables.

Its small size, anti-vibration and anti-interference capabilities make the PEC-3710 suitable for space-constrained, reverberating applications. The PEC-3710 is fanless and diskless, and has no internal cabling; such mechanisms make it capable of operating in temperatures of -10~60°C (14 ~149°F) without any heat issues.

Because the PEC-370 is based on standard PC-based architecture, it supports Win CE with pre-installed drivers and tools to control all I/O functions, therefore providing customers with an easy installation and faster development time.

## Conclusion

Advantech's PEC-3710 is an application ready platform, which has seamlessly integrated many I/O functions making it the ideal solution for demanding environments that require the obtaining and receiving of different types of data. Since the completion of the project, the customer has reported greater system reliability when using the PEC-3710 as a weighing controller.

## Project Implementation

Product	Specification
PEC-3710	AMD LX800 500 MHz Controller with 16-ch AI, 4-ch AO and 32-ch Isolated DI/O

## System Diagram

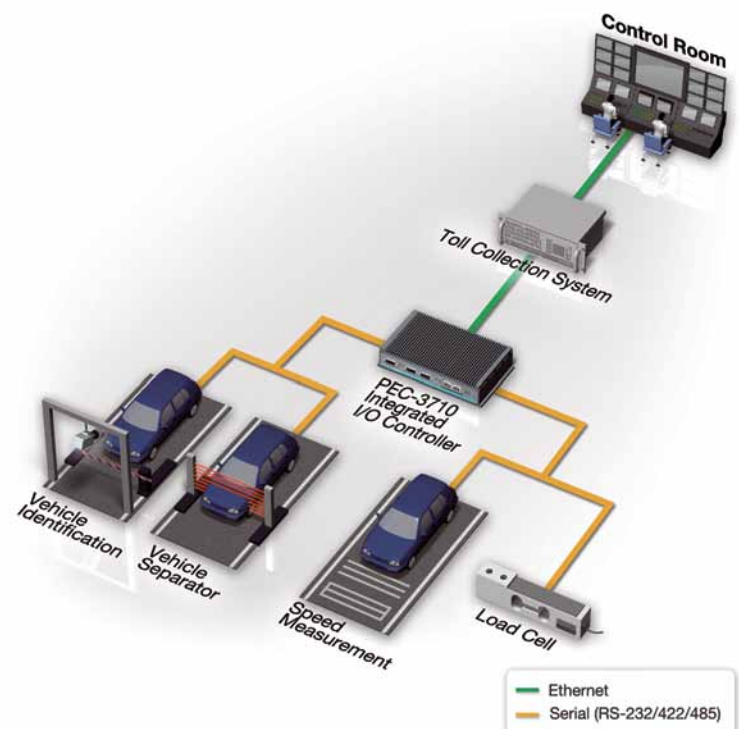



# Train-driving Simulator Optimization Using Advantech's Distributed Control System

China

## Introduction

In recent years, China has invested heavily in railway construction. The rapid development of railway systems has increased demand for qualified professionals in the railway industry, especially locomotive engineers. Advantech has previously developed a train-driving simulator to train and instruct new railway workers. Through simulating the conditions and surroundings of train operation, the train-driving simulator provides a highly realistic virtual driving environment. Using this system to instruct train drivers eliminates the need to use actual railway facilities for training, as well as negating the risk to safety of allowing a theoretically knowledgeable but inexperienced new driver actually operate trains.

## System Requirements

The train-driving simulator is a system that utilizes computer technology to control and simulate train-driving operations in real time. For many years, our customers have been using Advantech's Input/Output card solutions in training programs for railway workers. This simulator is installed in a 10 m<sup>2</sup> front compartment and the driving equipment is in front of and on both sides of the driver's seat. The basic requirement is to use the I/O board and module to read data. However, as the increasing complexity of the system has increased the number of I/O cards required, wiring and cabling work for the overall system has become an extensive and tedious task. Many customers have expressed their desire for a practical solution that streamlines the system while maintaining its original functionality.

## System Description

In response to customer needs, Advantech developed a distributed control system. The industrial personal computer IPC-610H is used as the monitoring host platform, and is integrated with an APAX high-density I/O module to read both analog and digital data.

As the host platform, the IPC-610H provides the operational screen for train control and processes various elements, such as simulation of scenery on the train route, scene changes, speed control, emergency incidents, etc. The APAX-5070 (Modbus/TCP coupler) serves as the communication bridge, connected to the IPC at one end and the I/O module at the other to obtain, store and transmit data. This special internal bus design facilitates operation through a distributed configuration.

In order to conduct an actual simulation of the control system, this system uses the APAX-5017H high-speed analog input module, which can capture the voltage signals of the power device. The APAX-5028 is applied for outputting analog signals to control the train speedometer. The APAX-5040 is used to detect the on/off status of the switch while the APAX-5046 can control alarm indicators and the on/off status of the circuit breaker. In addition, the APAX-5060 controls equipment requiring greater power, such as the switch of the speedometer backlight. Through the characteristics of the APAX modules, including high-density I/O, flexibility, scalability, and hot-swapping, customers can easily construct remote input and output systems.

## Conclusion

Advantech provides the excellent distributed system that enables configuring I/O modules according to the location of different equipment, thus reducing the need for cables by facilitating remote control. This simplifies the task of wiring or cabling, enhances system efficiency, while also reducing the costs borne by the customer.

## Project Implementation

Products	Specifications
APAX-5070	Modbus/TCP Communication Coupler with High Density I/O, Flexibility, Scalability, and Hot Swap Functionality
APAX-5017H	12-ch High Speed Analog Input Module
APAX-5028	8-ch Analog Output Module
APAX-5040	24-ch Digital Input Module
APAX-5046	24-ch Digital Output Module
APAX-5060	12-ch Relay Output Module
IPC-610H	4U Rackmount Chassis with Visual & Audible Alarm Notification

## System Diagram

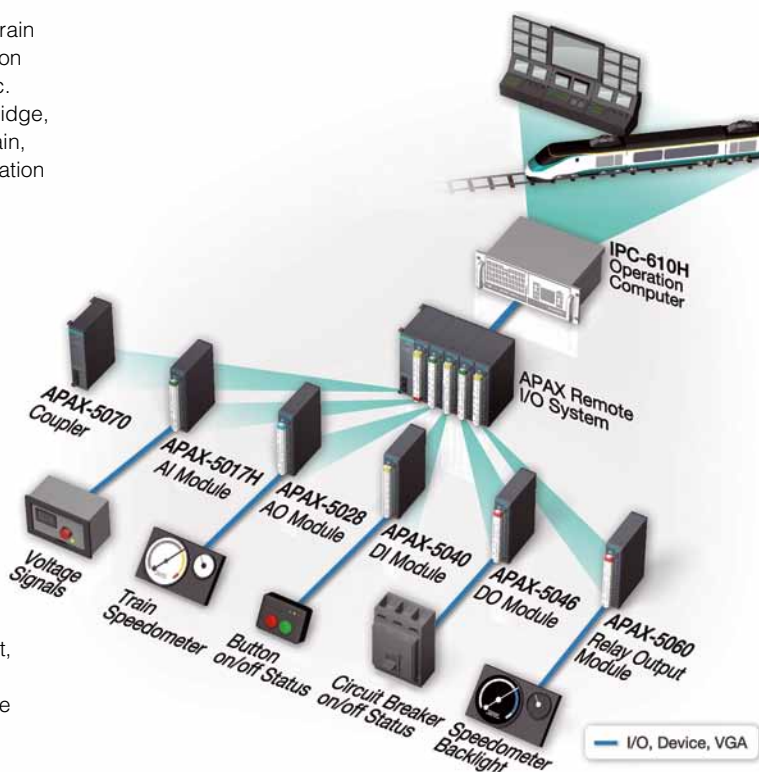



# China Railway High-speed Maintenance System

China



## Introduction

One of the best indicators of China's rapid economic growth should be transportation construction, especially concerning high speed rail projects. China is not only to adopt foreign systems but also invests a lot of efforts in trying to develop their own systems.

In 2007, with many years of experiences of railway rolling stock maintenance and repair, Beijing Railway Institute built its maintenance system for China Railway High-speed (CRH) including CRH Electric Multiple Unit Safety Monitoring System and the rail power system testing which is called the CJK-I Type Rigidly Movable Contact Net. Both of the systems are developed for the maintenance and repair tasks of trains and already have installed in many branch plants of Beijing Railway Institute.

## System Requirements

In the Wuhan factory, the inspection was carried out in a large warehouse (400 x 120 meters) through the programmable logic controllers (PLC) to collect signals and the data will be transmitted to the computer in the control room as well as being displayed on two different size LED monitors. There are a list of unique parameters that our client needed to be specified in the hardware specification including wide temperature range, anti-vibration, anti-interference and stable operation. Meanwhile, the Monitoring System requires a high performance IPC to meet the need for a 24 hours non-stop operation. The low power consumption is a basic demand for the CJK-I power system testing.

## System Description

Because the CRH Safety monitoring system must continuously operate for 24/7 and requires a large amount of data processing, the robust UNO-2182 with Intel® Core™ 2 Duo processor is the best choice as the system host needs to manage the PLC and other peripherals on site. On the other hand, Energy Star certified UNO-2173AF with Intel® Atom™ N270 processor was chosen for the CJK-I Type Rigidly Movable Contact Net power testing system, which requires only basic computing and data processing. In both monitoring and testing systems, data acquired from PLCs is transmitted to the UNO-2182 and UNO-2173AF to dynamically display the status, parameters and curve of the various devices including signal lights, LED monitors, operating room indicator lights, and audible and visual alarms via a graphical user interface that allows users to easily interact with devices via image commands. In addition, the UNO-2182 and UNO-2173AF send alerts via the integrated speaker to warn staff when abnormal situations are detected.

Furthermore, the fanless UNO-2182 and UNO-2173AF are designed for harsh environments, which make them ideal platforms for maintenance sites with high temperatures and 24/7 non-stop operation. Their wide operating temperature range of up to 70°C, anti-interference, anti-vibration, and dual Ethernet ports ensure their reliability and stability. Both of them not only meet our customer's specifications but also provide the best quality.

## Conclusion

Advantech's Embedded Automation Computers have always provided customers with high-performance application ready platforms as well as high efficiency. Regarding the UNO-2100 series, their robustness and reliability make them excellent choices for harsh environment applications.

## Project Implementation

Products	Specifications
UNO-2182	Intel® Core™ 2 Duo Automation Computer with 2 x GbE, 4 x COM ports, DVI
UNO-2173AF	Intel® Atom™ N270 Automation Computer with 2 x LAN, 3 x COM ports, Mini PCIe

## System Diagram

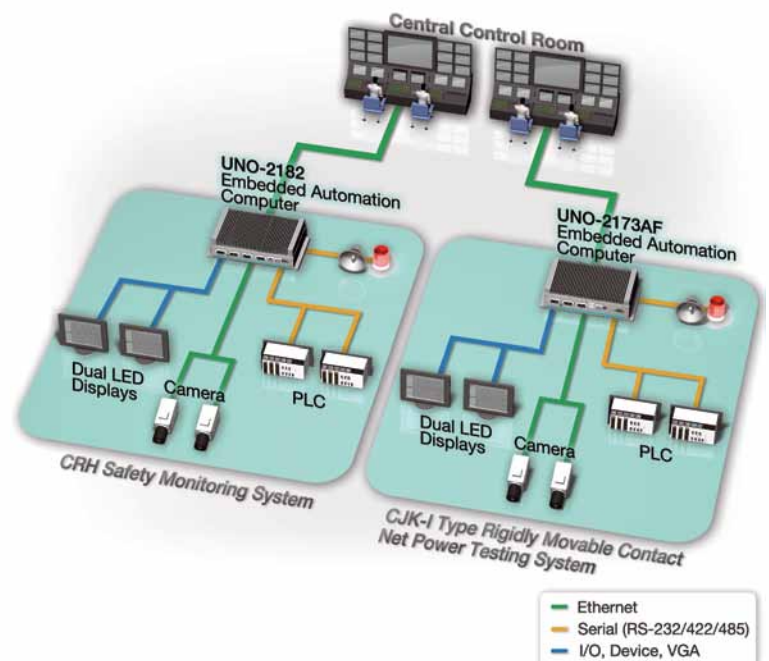

# Power & Energy Management

## Build Reliable Power Automation Solutions with Trusted System Components

Power supply and demand are becoming more and more critical. Substation automation, T&D grid automation, renewable energy, power generation & transmissions, energy management systems and maintenance-free power backup systems with IEC 61850-3 compliance are the big trends in today's applications. Power Automation improves energy efficiency and intelligence while also implementing important environment protection and green powered features. Advantech is proud to develop reliable HMIs, Open Embedded Controllers, Managed Switches and Programmable Automation Controllers to serve this market.



### Power Generation

Advantech provides reliable and high performance components to help customers develop more efficient power backup solutions, nuclear simulation system and a generator monitoring system and more.



### Power Distribution

Advantech's Substation Automation Solutions provide robust IEC 61850-3/IEEE 1613 compliant devices and components, computing platforms, protocol gateways and networking switches to ensure interoperability and interconnection between substations and power systems.



### Renewable Energy

With harsh environment factors, such as drastic day-night temperature differences, dust/sand storms, vibration, heat and electrical noise, Advantech provides rugged, reliable and real-time communication, monitoring, tracking, testing and DAQ control solutions for renewable energy applications.



### Electric Car Charging Stations

Advantech's touchscreen controlled industrial computer systems, serial modules, switches and data acquisition modules serve as system components for data acquisition and transmission among separate EV/PHEV charging posts, with precise monitoring and control.

## Product Solutions

### HMI



**FPM-3151G**  
15" XGA Industrial Monitor

### Controllers



**APAX-5570**  
PAC with Intel Celeron M CPU



**APAX-5620**  
PAC with XScale CPU and CANopen



**UNO-1170A/AE**  
Intel® Atom™ N270 DIN-rail PCs



**UNO-4673A**  
IEC 61850-3/IEEE 1613 Automation Computer

### Communications



**EKI-4654R**  
IEC 61850-3/IEEE 1613 Industrial Ethernet Switch



**EKI-7559SI/MI**  
8+2 SC-type Fiber Optic Managed Ethernet Switches

### I/O



**APAX-5017H**  
12-ch High Speed Analog Input Module

# Solar Thermoelectric Control System

China



## Introduction

The sun is a huge source of abundant power, sending nearly 10,550 EJ of energy to the Earth every day. This is more energy in one hour than all the combined cities of the world use in one year. To try and harness this magnificent power, many countries have been investing in solar technologies for over 30 years. Today's solar thermoelectric systems include reflectors, mirrors, heat insulating absorbers and advanced motion control technology. Advantech's own Industrial Wireless Ethernet products are a perfect fit for many such applications due to their great performance, reliability and ruggedness.

## System Requirements

Wireless communications are an excellent complement to industrial wired solutions for many applications. In a typical solar thermoelectric control system, a combination of wired and wireless communications can effectively solve problems related to data transmission and field application issues. Two connection modes are supported; Infrastructure and Ad-hoc. When in Ad-hoc mode, the wireless network card does not require a huge network structure and a high-speed, simple network can be built without a lot of end-user effort. In this solar thermoelectric control system, the client required a wireless network with the following requirements:

- Industrial grade equipment with high electromagnetic compatibility
- Fanless products to operate in extreme environments with high temperatures and humidity
- Long MTBF
- Easy network management

## System Description

WLAN Access Points (AP) are very similar to an Ethernet switch. On one hand, each AP communicates with regular nodes (Clients) regardless of whether they are fixed nodes or mobile nodes. On the other hand, APs can connect directly to each other through a cable or an independent wireless network, thus realizing communications without the limitations of a wireless network.

This solution adopted Advantech's Wireless AP EKI-6311GN and Wireless EKI-1351 Serial Device Server. 100 PLCs have been deployed in the field, and each PLC adopted Wireless mode to transmit information to the host computer. Moreover, these PLCs are far away from the central control room. Therefore, Advantech recommended to the ratio of 1 Wireless AP for every 10 PLCs to guarantee reliable wireless network transmissions. The Wireless APs apply WDS (Wireless Distribution System) technology allowing them to be bridged flexibly, making it easy to transmit data to all of the 100 PLCs through 100 EKI-1351's and then upload all relevant information to the central control room.

## Project Implementation

Products	Specifications
EKI-6311GN	802.11 b/g/n Wireless Access Point/ Client Bridge
EKI-1351	1-port RS-232/422/485 to 802.11 b/g Wireless Serial Device

## Conclusion

Advantech's EKI-6311GN AP provides 54 Mbps high speed transmission rates, 128-bit WEP encryption, an IP55-based dust-proof and waterproof design and enhanced dual antennas, thus greatly improving wireless transmissions and building a reliable wireless communication platform in a rough industrial environment.

## System Diagram

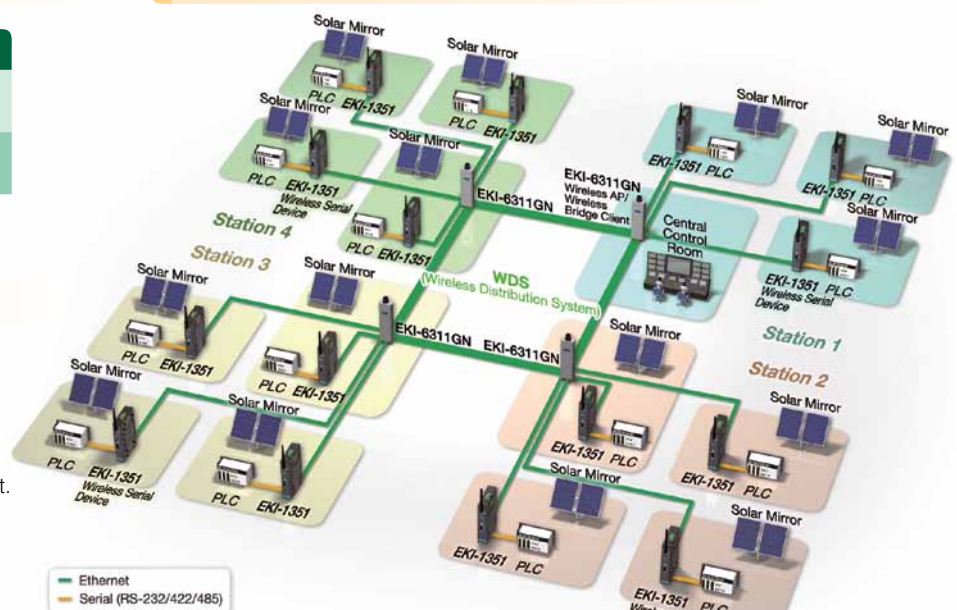

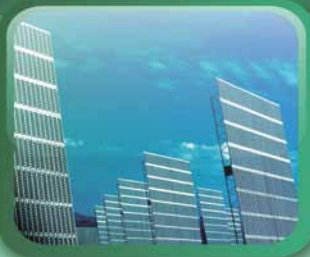

# Sun Tracking System for Solar Energy

China

## Introduction

Based on its very nature, solar energy isn't available 24 hours a day. Making the most of our sun energy requires highly efficient solar cells and advanced sun tracking systems. Sun tracking allows the solar cells to face the strongest sunlight while it is available, so they need to be able to detect the strength of sunlight in different directions to determine the best location for the strongest sunlight. The solar plates must be constantly adjusted to the correct angle and direction by the sun tracker system, which requires a multi-axis motion control system.

## System Requirements

Because sun tracker systems are installed in outdoor areas in direct sunlight, the devices in the system need to be able to withstand harsh environments and have wide operating temperatures. This particular system also required a robust DAQ module to measure voltage from different transmitters and a reliable controller with precise stepping control.

## System Description

The ADAM-4117 measures the input voltage signal from the sunlight transmitters to detect the direction of the strongest sunlight, then informing the result to PEC-3240 in order to get the best performance for the solar cell modules. The horizontal transmitters help the system to detect the position of solar plate while the tracker transmitters are used to detect the sunlight strength. On the other hand, the PEC-3240 controls the stepper motors of the sun tracker system. If the different strength of the sunlight is detected between two transmitters, the PEC-3240 will calculate the sunlight strength difference to adjust the stepper motors to find the optimal position of the solar cell module. If there is no difference of the sunlight strength between two transmitters, it means the solar cell module is in the optimal direction of sunlight. The system can keep track the relative data to adjust the stepper motors to control the angular and position of the solar cell module for getting the best performance.

## Conclusion

After implementing the PEC-3240 as the control mechanism for this application, the sun tracker system has operated efficiently and reliably without any breakdown or downtime. This positioning system outlines the inherent strength and benefits of the PEC-3240, which is suitable for many similar motion control applications. Not only can this Embedded Motion Controller simplify existing system architectures to save costs, but its rugged design provides a very reliable solution. Combined with the ADAM Remote I/O module, the PEC-3240 offers more flexibility for different system requirements.

## Project Implementation

Products	Specifications
ADAM-4117	8-ch Analog Input Module with Modbus
PEC-3240	Intel® Celeron® M 1.0 GHz 4-axis Embedded Motion Controller with 32-ch Digital I/O

## System Diagram

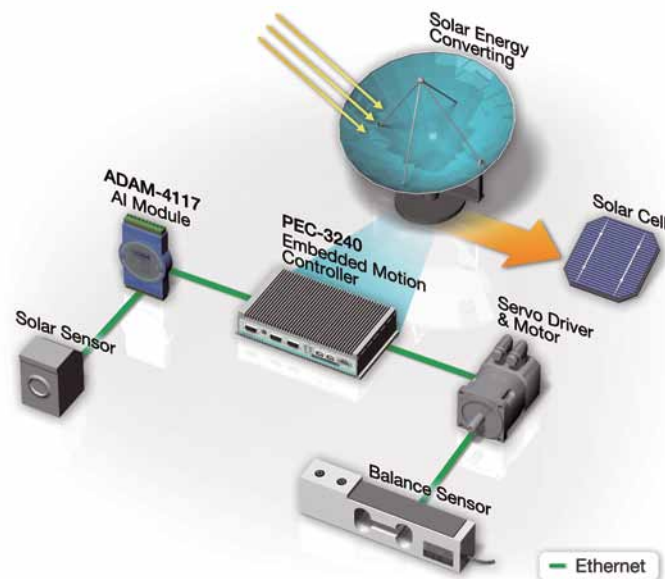

# Control Solution for Solar Energy Monitoring System

Taiwan



## Introduction

The Hsinta Power Plant is a large thermal power station located in the Yong-an township of Kaohsiung County. To take advantage of its geographical position in southern Taiwan, Hsinta has begun developing an expansive solar power facility with a 1 megawatt capacity as part of the government's effort to tap into new renewable energy technologies.

## System Requirements

This project aimed to install over 4,500 solar panels, with a total generation capacity of 953.19 KW. The Taiwan Power Plant was looking to develop a system to oversee the metering and analysis of sunlight data, power generation data, and controlled grid-connection, specifically data metering, equipment control, and power conversion to the grid. The collection and analysis of data was also very important, such as sunlight strength, overall direct current power, average energy conversion efficiency of the solar cell modules, alternating current power output of the power converters, average conversion efficiency of the power converters, direct current power ratio, total system operation hours, accumulated carbon dioxide reduction, and accumulated direct and alternating current power generation.

## System Description

In order to collect accurate sunlight data and evaluate solar panel effectiveness, the system needed to have a robust and compact controller for power plant control inquiry, analog signal measurements, fast data sampling, recording and analysis, and remote configuration, troubleshooting and maintenance.

Advantech's PAC products serve as power controllers because of their ability to meter, record, control, store and provide remote maintenance functionalities, which are excellent for solar power applications. ADAM-5550KW is particularly remarkable in its capacity, providing multi-functional data acquisition modules. SoftLogic, also provided by Advantech, allows the engineers to program with ease.

The ADAM-5017 is an analog input module used to collect weather information, such as temperature on the solar panels, the amount of sunlight, and the shading temperature. It also meters and analyzes the power storage and energy conversion at the solar cells and recording data of current and voltage. The ADAM-5550KW is used as the control host, with fast computing capacity overseeing the DC to AC conversion process, analyzing equipment efficiency, and detecting the service life length of voltage converters. The ADAM-5053S is a digital input module which collects critical alarms, temperature sensors, thermal overshoot, IGBT over Temperature, contactor, CT, MOV, and VAC sense circuits. The ADAM-5056 acts as a digital output module to precisely control status of gas circuit breaker switching and power connection to the utility grid.

## Conclusion

In this solar panel power generation application, Advantech's PAC products, with their fast and powerful capacity in metering, recording, controlling and saving, and outstanding features in remote maintenance and multi-function data acquisition modules, along with provided professional software pack, proved an excellent choice.

## Project Implementation

Products	Specifications
ADAM-5550KW	8-slot Micro PAC with GX2 CPU
ADAM-5017	12-ch Analog Input Module
ADAM-5053S	24-ch Digital Input Module
ADAM-5056	24-ch Digital Output Module

## System Diagram

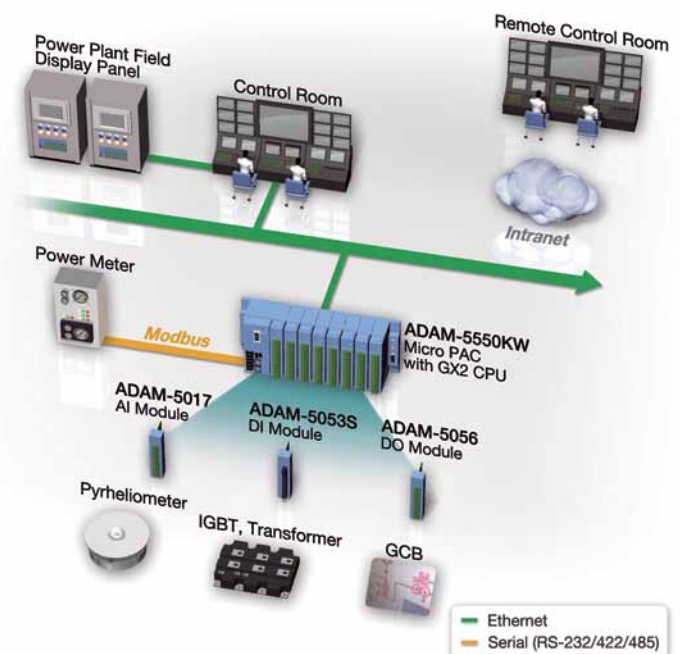



# Photovoltaic Plant Management Solution

Italy

## Introduction

Our customer is a local system integrator with extensive experience in the photovoltaic market. One of their main focuses is solar inverter manufacturing, which brings them most of their business. Recently, their business has grown more and more in this area and thanks to strong demand for environmental applications that growth is expected to continue. For this specific application, the customer was looking for different PC controllers based on the specific requirements of the plants, as well as one single and trusted partnership with an experienced and consolidated brand that can provide added value.

## System Requirements

The requirement of this specific application was to find different Embedded PC platforms with different consumption levels, but with low power specifications and fanless design in order to save costs, plus a compact design to save space. Other requirements included: 4 COM ports (3 x RS-485), 2 LAN ports, isolation and, last but not least, a competitive price.

## System Description

This specific application involves three different photovoltaic plants, each of them with a dedicated data logger and a specific PC Controller. Each PC Controller helps to collect data, calculate parameters and forward all information to the central station through EKI-2725/2728, 5/ 8-port Gigabit Unmanaged Ethernet Switches for further monitoring. Depending on the power requirements and eventual data acquisition functions needed, three different PCs were adopted for different photovoltaic plants: the ARK-1310, cost-effective Automation System Solution; the ARK-3360, Intel® Atom™ High Value Automation Control Box; and the UNO-1140, Embedded DIN-rail PC Controller. In the end, all information is shown through a monitor and managed with proprietary HMI software made by the customer.

## Project Implementation

Products	Specifications
ARK-1310	Cost-effective Automation System Solution
ARK-3360	Embedded IPC with Intel® Atom™ Processor and Isolated COM Ports
EKI-2725/2728	5/8-port Gigabit Unmanaged Ethernet Switch
UNO-1140	Embedded DIN-rail PC Controller with 1 x LAN and 4 x Isolated COM Ports

## Conclusion

The customer chose Advantech because of the high quality and reliability of all three systems whilst being able to reduce their costs. In addition, Advantech's global service network and the trusted partner in Italy were able to provide high quality service and necessary added value. Thus, Advantech was able to provide a reliable all-in-one vendor solution for Photovoltaic Plant Management.

## System Diagram

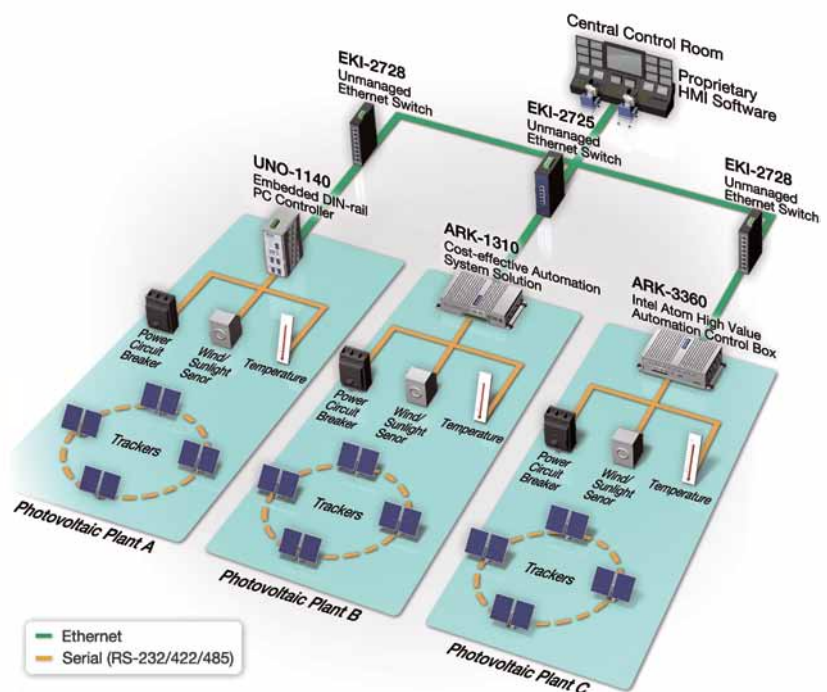

# A Total Solution Elevates the Performance of a Wind Farm

China



## Introduction

As an alternative to fossil fuels, wind power is a plentiful, renewable, widely distributed and clean energy. Due to these characteristics, wind energy has become an important player in the world's energy markets. A large wind farm may consist of several hundred individual wind turbines connecting to the electric power transmission network. Most wind farms are located in sparsely populated areas with harsh environments and only a few maintenance staff. Because of their location, the problem of how to ensure the wind power plant can be operated safely and reliably is an essential and very important issue.

## System Requirements

Our customer is one of five major power generation companies in China with more than hundred wind farms around the country. They plan to adopt the Wind Power Management System (WPMS) with robust hardware devices to monitor their multiple power plants in real time. Therefore, the system not only needs to be able to be controlled via remote control, but also to provide the data upload program to generate regular reports which can help administrators to analyze the availability of the wind turbine or electricity generation. The hardware also needs to support a wide operating temperature range and provide protection against interference. In order to enhance long-distance transmission and data reliability, the network devices also need to support a fiber optic redundant ring backbone.

## System Description

Advantech's WPMS is based on an advanced and reliable platform, Advantech WebAccess integrated the customer's local wind power systems, including a wind turbine control system, high voltage station supervision system and video surveillance systems via a unified access interface as well as collecting real-time data to the control center in headquarters. WPMS not only completes the data collection, storage and processing, configuration, and condition monitoring for cluster management needs but also simultaneously communicates with multiple power station systems to ensure the timeliness, accuracy and completeness of the data. Its remote control feature enables the customer to access and monitor the wind power plant from anywhere.

As for the hardware devices, each wind turbine tower is equipped with an EKI-7554SI Ethernet switch linked to the redundant ring via a single-mode optical fiber. The EKI-7554SI uses the proprietary X-Ring redundant network protocol which provides users an easy way of establishing a redundant Ethernet network with an ultra high-speed recovery time of less than 10ms. Each of the wind turbine towers connects to the EKI-4654R at a control center to transmit the data to an IPC-620 local server. The EKI-4654R has a long range voltage redundancy power input which provides a convenient and uninterrupted power supply to guarantee network safety. Advantech also provides a reliable platform, TPC-1251H, for the on-site mobile operation to transmit the wind turbines' data to the local wind power system via Ethernet.

## Conclusion

With Advantech's total solution, the WPMS is qualified to exceed the expectations of our customer in need of the distributed management to remotely control their system in real time; meanwhile, our hardware devices with exclusive networking technology provide an effective and efficient network infrastructure to connect the hundred wind turbines.

## Project Implementation

Products	Specifications
<b>Advantech WebAccess</b>	Browser-based HMI/SCADA Software
<b>WPMS</b>	Wind Power Management System (Browser / Server Software)
<b>IPC-620</b>	20-slot Multi-system Rackmount IPC Chassis
<b>TPC-1251H</b>	12.1" SVGA TFT LCD Intel® Atom™ Touch Panel Computer
<b>EKI-7554SI</b>	4+2 SC Type Fiber Optic Managed Industrial Ethernet Switch with Wide Temperature
<b>EKI-4654R</b>	24+2 SFP Port Managed Redundant Industrial Ethernet Switch

## System Diagram

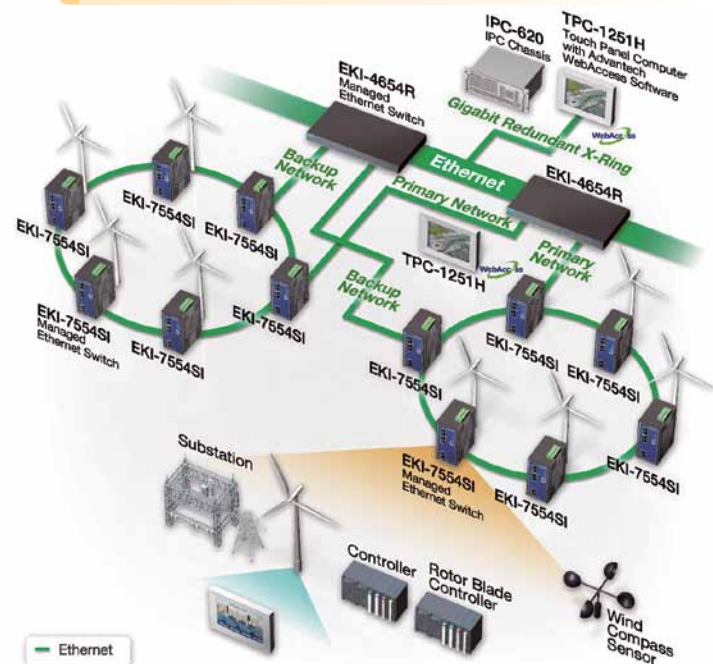



# Standalone Fuel Cell Power Generation Station

Taiwan

## Introduction

Energy efficiency is an increasingly important issue. Renewable energy solutions, such as solar cells, wind power, and fuel cells are good alternatives over traditional energy sources to further this cause. Fuel cells are electrochemical cells that convert source fuels into electrical currents. They generate electricity through reactions between a fuel and an oxidant. One Taiwanese fuel cell manufacturer is building a standalone distributed power generation station using fuel cells as the energy source. This fuel cell power generation could be located in parks, hotels, public institutes or even homes.

## System Requirements

The client wants to build a complete system to monitor and control the fuel cell reaction process. A reliable controller is needed because the power station is located far from control center room. Other system requirements include:

- The ability to easily deploy the system using the LabVIEW graphical development environment
- Possible to maintain and manage the station remotely through Ethernet
- Compact and robust controller and I/O with hot-swapped functionality
- Data logging both remotely and locally

## System Description

The source fuel (reactant, here is hydrogen) flows into the cell, generates electricity by the reaction through the oxidant (here it's the air controlled by a pump). The APAX-5045 Digital Output module is used to control the valve and the pump, controlling the reaction process. Pressure sensors connected to the APAX-5017 Analog Input module, which monitors how much hydrogen is flowing into the cell. The generated electricity is measured by the APAX-5017 module, making the system capable to calculate power generation efficiency. The output electricity can be used on the load, or transfer to alternating current for usage. During the reaction, a fan is needed to control the environment temperature to ensure the best power generation efficiency. The APAX-5045 can be used to control the cooling fan, and the APAX-5018 can trace the environment temperature. the APAX-5570XPE features an open platform which makes it easy to perform data storage. Combined with a wireless AP, data on the APAX-5570XPE can be transferred to remote PC.

## Project Implementation

Products	Specifications
APAX-5570XPE	PC-based Controller with Intel® Celeron® M CPU
ADAM-5017	12-ch Analog Input Module
APAX-5018	12-ch Thermocouple Input Module
APAX-5045	24-ch Digital Input/output Module

## Conclusion

The APAX-5570XPE allows engineers to seamlessly develop programs through LabVIEW and execute on APAX-5570XPE without additional effort. Advantech's APAX series helped this client shorten the time-to-market, because engineers can leverage their knowledge of LabVIEW. Openness and flexibility are perfectly combined with reliable features. Another important benefit brought by this Advantech solution is that APAX analog modules can be configured with different channels with different input types and ranges. This helps clients save stock, costs and installation space.

## System Diagram

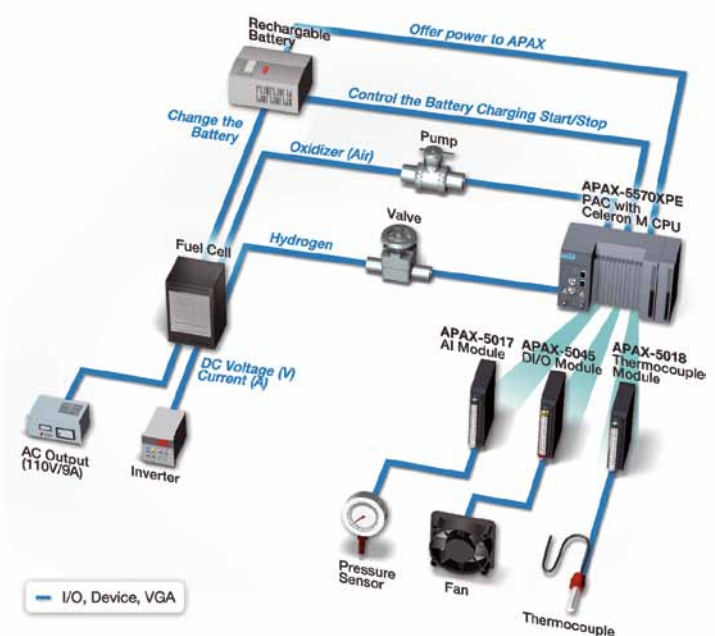



# Advanced Power Management Station

Taiwan



## Introduction

As energy saving and carbon reduction issues become more widespread, it is more important than ever to have advanced power management stations to measure, analyze and optimize power consumption to improve energy efficiency. A large corporation in Taiwan sought Advantech's Data Acquisition solution to help them develop a new power management station in order to improve their energy usage to reduce costs and their impact on the environment.

## System Requirements

The more efficient the monitoring of power consumption, the more costs and energy can be saved. When this customer wanted to build a new power management station (in which precious watt-hour meters play a crucial role), they were extremely concerned with the quality of data acquisition devices they installed in the system. Thus, they turned to Advantech with the following requirements:

- High-accuracy and high-precision measurement
- High-speed analog input to estimate 60 Hz sine wave signals
- Easy programming development for engineers
- Isolated counter card to acquire high voltage clock signals

## System Description

Since the watt-hour meter has a dry contact output, the voltage signal cannot be measured by general DAQ products. Due to the 2,500 V<sub>DC</sub> isolation protection of the PCI-1750, it can be used to recognize the frequency in order to respond whenever the electricity is conducted and also get rid of the usage of voltage divider. Meanwhile the PCI-1710's high speed analog input measures the time period by reading the pulse numbers. Utilizing these cards and the A-DAQ Pro software allowed this customer to measure their power consumption accurately and easily.

## Project Implementation

Products	Specifications
A-DAQ Pro	ActiveX Control-based Software for Data Acquisition
PCI-1750	32-ch Isolated Digital I/O and 3-ch Counter PCI Card
PCI-1710	100 kS/s, 12-bit, 16-ch PCI Multifunction Card

## Conclusion

Advantech offers a wide range of data acquisition modules for customers to choose from; therefore engineers do not have to spend extra time to integrate multiple data acquisition modules from different vendors. This solution also allows the customer to easily maintain and expand the system in the future.

## System Diagram

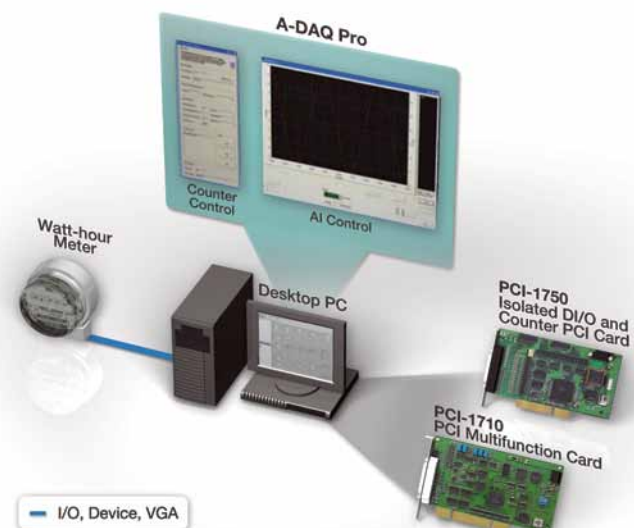



# Monitoring Quality and Consistency of Electricity Supply

United States

## Introduction

To ensure that customers' equipment isn't damaged, electricity suppliers need to ensure that the voltages delivered to customers are at an even level. They achieve this by the continual monitoring of the supply equipment.

## System Requirements

Our American client, an electricity supplier, required a method of monitoring the quality and consistency of the power being delivered to their customers. The company was looking for a system that was easy and cost effective to install whilst being able to connect to their existing equipment. Their existing sensor equipment, responsible for measuring the voltage of the power supply, outputted the data in AC, but the monitoring equipment needed to receive this information as DC.

## System Description

To convert the sensor data from AC to DC the client attached each sensor to an ADAM-3112, an isolated AC voltage input signal conditioner that supports three different AV voltage input modes (120V, 250V and 400V) and transduces them into 0 ~ 5 V<sub>DC</sub> output. As a rectifier, the ADAM-3112 then sends the converted DC volts to an ADAM-4017+ .16-bit, 8-channel analog input module, which is connected to the clients monitoring equipment via RS-485. Since this is a modular system, it is easily expandable, thus allowing our client to add additional sensors to the supply equipment.

## Project Implementation

Products	Specifications
ADAM-3112	Isolated AC Voltage Input Module
ADAM-4017+	8-ch Analog Input Module with Modbus

## Conclusion

The deployment of the ADAM-3112 and ADAM-4017+ modules meant that the client was successfully able to monitor their equipment and address issues as they arose.

## System Diagram

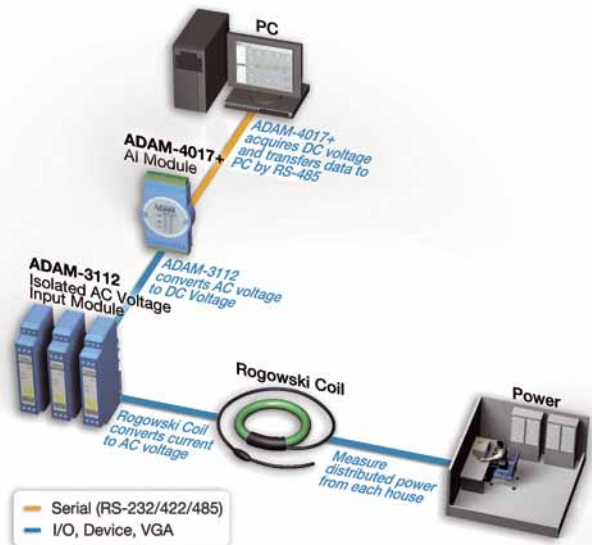

# A Total Solution for Electronic Vehicle Charging Stations

Hong Kong



## Introduction

Building a low-carbon economy has become a key measure in tackling the challenges of climate change. In many countries, policies and plans have been established for transition to a low-carbon economy. One of the key strategic tools for this transition is Electronic Vehicles (EVs) which, in recent years, have gained mainstream attention as viable alternatives to gasoline-powered cars. In Hong Kong, the government is continuously identifying possible ways to encourage vehicle owners to use cleaner alternative fuel vehicles. Its pro-active approach for promoting the use of electric vehicles is to cooperate with developers to set up the EV charging facilities.

## System Requirements

In order to promote low carbon living, last year, the Hong Kong government introduced EV Charging Stations. The charging pole provides three kinds of plugs, to fit different vehicles, for charging and due to fast-charging battery technology it only takes 2 to 8 hours to be fully charged. The pole is attached to a touch screen with a graphical user interface and card payment system to allow users to pay in multiple ways. To meet the specifications for human machine interaction, the charging equipment needs a variety of I/O modules to acquire meter data and control the various switches as well as managing the power grid to charge and discharge. The whole system also needs a reliable and low-cost IPC platform, which needs to provide an optical interface to connect the EV Charging Stations to complete the charging.

## System Description

Based on the system requirements, Advantech provided a stable low-cost 10.4" touch panel computer - TPC-1070H - as the charging system host to control the three charging sockets. Each socket is attached to an EKI-1521 to acquire the meter data and an ADAM-6052 to the control various switches. The EKI-1521 is a 1-port RS-232/422/485 Serial Device Server with two independent Ethernet ports and MAC addresses to provide a redundant network mechanism to guarantee Ethernet network reliability. With 8 digital inputs and 8 digital outputs, the ADAM-6052 is suitable for any other type of low current applications that need to be carefully controlled. Its built-in communication watchdog and network failure safety functions can reset the outputs to pre-configured values if network failure occurs.

The TPC-1070H easily connects all devices in the charging pole via Advantech's industrial Ethernet Switch, EKI-7626C. Its 2 GB fiber optic/copper combo ports enable interconnection of the system and the charging station network via fiber optic network. By being connected to the USB-4761 data acquisition module, the TPC-1070H can also control the buttons, switches and light signals in the master control box. With the features of easy installation and lockable cable mechanism, the USB-4761 is a reliable 8-ch relay and 8-ch isolated digital input USB module as well as featuring an isolation protection for rugged applications.

## Conclusion

Reliability is always a priority with Advantech products, and our platform for this case is no exception. It is a reliable, compact and easy to wire solution as well as eliminating the compatibility issues because all devices are manufactured by Advantech.

## Project Implementation

Products	Specifications
ADAM-6052	16-ch Source-type Isolated Digital I/O Modbus TCP Module
EKI-1521	1-port RS-232/422/485 Serial Device Server
EKI-7626C	16+2G Combo Port Gigabit Unmanaged Industrial Ethernet Switch
TPC-1070H	10.4" SVGA TFT LCD Intel® Celeron® M Touch Panel Computer
USB-4761	8-ch Relay and 8-ch Isolated Digital Input USB Module

## System Diagram

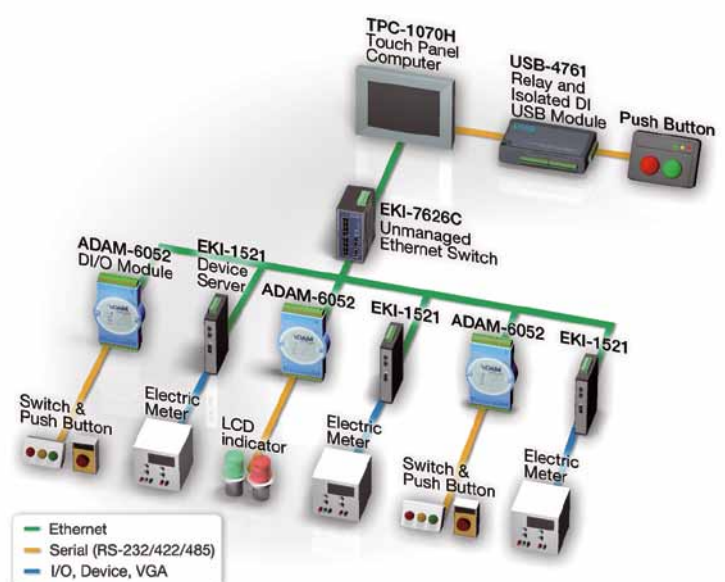

## Regional Service & Customization Centers

### China

Kunshan  
86-512-5777-5666

### Taiwan

Taipei  
886-2-2792-7818

### Netherlands

Eindhoven  
31-40-267-7000

### Poland

Warsaw  
48-22-33-23-740/ 741

### USA/ Canada

Milpitas, CA  
1-408-519-3898

## Worldwide Offices

### Greater China

#### China

**Toll Free** 800-810-0345  
Beijing 86-10-6298-4346  
Shanghai 86-21-3632-1616  
Shenzhen 86-755-8212-4222  
Chengdu 86-28-8545-0198  
Hong Kong 852-2720-5118

#### Taiwan

**Toll Free** 0800-777-111  
Rueiguang 886-2-2792-7818  
Yang Guang 886-2-2792-7818  
Xindian 886-2-2218-4567  
Taichung 886-4-2378-6250  
Kaohsiung 886-7-229-3600

### Asia Pacific

#### Japan

**Toll Free** 0800-500-1055  
Tokyo 81-3-6802-1021  
Osaka 81-6-6267-1887

#### Korea

**Toll Free** 080-363-9494  
Seoul 82-2-3663-9494

#### Singapore

Singapore 65-6442-1000

#### Malaysia

**Toll Free** 1800-88-1809  
Kuala Lumpur 60-3-7724-3555  
Penang 60-4-397-3788  
60-4-397-4188

#### Indonesia

Jakarta 62-21-7690525

#### Thailand

Bangkok 66-2-248-3140

#### India

**Toll Free** 1800-425-5070  
Bangalore 91-80-2337-4567

#### Australia

**Toll Free** 1300-308-531  
Melbourne 61-3-9797-0100  
Sydney 61-2-9476-9300

### Europe

#### Germany

**Toll Free** 00800-2426-8080  
Münich 49-89-12599-0  
Hilden 49-2103-97-885-0

#### France

Paris 33-1-4119-4666

#### Italy

Milano 39-02-9544-961

#### Benelux & Nordics

Breda 31-76-5233-100  
Roosendaal 31-165-550-505

#### UK

Reading 44-0118-929-4540

#### Poland

Warsaw 48-22-33-23-740/741

#### Russia

**Toll Free** 8-800-555-01-50  
Moscow 7-495-232-1692

### Americas

#### North America

**Toll Free** 1-888-576-9668  
Cincinnati 1-513-742-8895  
Milpitas 1-408-519-3898  
Irvine 1-949-789-7178

#### Brazil

**Toll Free** 0800-770-5355  
Saude-São Paulo 55-11-5592-5355

# ADVANTECH

Enabling an Intelligent Planet

[www.advantech.com](http://www.advantech.com)

Please verify specifications before quoting. This guide is intended for reference purposes only.

All product specifications are subject to change without notice.

No part of this publication may be reproduced in any form or by any means, electronic, photocopying, recording or otherwise, without prior written permission of the publisher.

All brand and product names are trademarks or registered trademarks of their respective companies.

© Advantech Co., Ltd. 2012

2000020796