



User Manual

MIO-5850

ADVANTECH

Enabling an Intelligent Planet

Copyright

The documentation and the software included with this product are copyrighted 2018 by Advantech Co., Ltd. All rights are reserved. Advantech Co., Ltd. reserves the right to make improvements in the products described in this manual at any time without notice. No part of this manual may be reproduced, copied, translated or transmitted in any form or by any means without the prior written permission of Advantech Co., Ltd. Information provided in this manual is intended to be accurate and reliable. However, Advantech Co., Ltd. assumes no responsibility for its use, nor for any infringements of the rights of third parties, which may result from its use.

Acknowledgements

Intel® is a trademark of Intel® Corporation.

AMI is a trademark of American Megatrends, Inc.

IBM, PC, PS/2 and VGA are trademarks of International Business Machines Corporation.

Microsoft Windows®, DirectX® is a registered trademark of Microsoft Corp.

All other product names or trademarks are properties of their respective owners.

For more information on this and other Advantech products, please visit our websites at:

<http://www.advantech.com>

<http://www.advantech.com/eplatform>

For technical support and service, please visit our support website at:

<http://support.advantech.com/>

This manual is for the MIO-5850.

Product Warranty (2 years)

Advantech warrants to you, the original purchaser, that each of its products will be free from defects in materials and workmanship for two years from the date of purchase.

This warranty does not apply to any products which have been repaired or altered by persons other than repair personnel authorized by Advantech, or which have been subject to misuse, abuse, accident or improper installation. Advantech assumes no liability under the terms of this warranty as a consequence of such events.

Because of Advantech's high quality-control standards and rigorous testing, most of our customers never need to use our repair service. If an Advantech product is defective, it will be repaired or replaced at no charge during the warranty period. For out-of-warranty repairs, you will be billed according to the cost of replacement materials, service time and freight. Please consult your dealer for more details.

If you think you have a defective product, follow these steps:

1. Collect all the information about the problem encountered. (For example, CPU speed, Advantech products used, other hardware and software used, etc.) Note anything abnormal and list any onscreen messages you get when the problem occurs.
2. Call your dealer and describe the problem. Please have your manual, product, and any helpful information readily available.
3. If your product is diagnosed as defective, obtain an RMA (return merchandise authorization) number from your dealer. This allows us to process your return more quickly.
4. Carefully pack the defective product, a fully-completed Repair and Replacement Order Card and a photocopy proof of purchase date (such as your sales receipt) in a shippable container. A product returned without proof of the purchase date is not eligible for warranty service.
5. Write the RMA number visibly on the outside of the package and ship it prepaid to your dealer.

Declaration of Conformity

CE

This product has passed the CE test for environmental specifications. Test conditions for passing included the equipment being operated within an industrial enclosure. In order to protect the product from being damaged by ESD (Electrostatic Discharge) and EMI leakage, we strongly recommend the use of CE-compliant industrial enclosure products.

FCC Class A

This equipment has been tested and found to comply with the limits for a Class A digital device, pursuant to part 15 of the FCC Rules. These limits are designed to provide reasonable protection against harmful interference when the equipment is operated in a commercial environment. This equipment generates, uses, and can radiate radio frequency energy and, if not installed and used in accordance with the instruction manual, may cause harmful interference to radio communications. Operation of this equipment in a residential area is likely to cause harmful interference in which case the user will be required to correct the interference at his own expense.



Caution! *There is a danger of a new battery exploding if it is incorrectly installed. Do not attempt to recharge, force open, or heat the battery. Replace the battery only with the same or equivalent type recommended by the manufacturer. Discard used batteries according to the manufacturer's instructions.*

Technical Support and Assistance

1. Visit the Advantech website at <http://support.advantech.com> where you can find the latest information about the product.
2. Contact your distributor, sales representative, or Advantech's customer service center for technical support if you need additional assistance. Please have the following information ready before you call:
 - Product name and serial number
 - Description of your peripheral attachments
 - Description of your software (operating system, version, application software, etc.)
 - A complete description of the problem
 - The exact wording of any error messages

Packing List

Before you begin installing your card, please make sure that the following materials have been shipped:

- 1 x MIO-5850 SBC
- 1 x SATA Cable 30cm (p/n: 1700006291)
- 1 x SATA Power Cable 35cm (p/n: 1700018785)
- 1 x Audio Cable 20cm (p/n: 1700019584)
- 2 x COM Cable 22cm (p/n: 1701200220)
- A cable D-SUB 9P/1*3p-1.25+G-TEM 30cm (p/n: 1700021705-01)
- 1 x Heatsink (19mm) (p/n: 1960087101T001)
- 1 x Startup manual (p/n: 2006585000)
- 1 x Mini Jumper(10pcs package) (p/n: 9689000002)

If any of these items are missing or damaged, contact your distributor or sales representative immediately.

Optional Accessories

Part number	Description
TBD	Heat spreader
1757003934	Adapter 100-240V 60W 12V 5A W/O PFC
1703100264	Internal 1-Port USB cable 22.5cm
SQF-SHMM2-32G-S9	mSATA 32G
96FD-I128-TR1	mSATA 128GB
SQF-S25M8-2T-SAC	2.5" SATA SSD
SQF-S25U8-512G-SAE	2.5"SATA SSD
EWM-W160M201E	M.2 Key A+E (Wireless LAN)
EWM-W163M201E	M.2 Key A+E (Wireless LAN +Bluetooth)
IDK-1107WP-50WVA1E	7" Panel
IDK-1110WP-50XGA1E	10.1" Panel
IDK-1115P-50XGA1E	15" Panel

Contents

Chapter 1	General Information	1
1.1	Introduction	2
1.2	Specifications	2
1.2.1	Functional Specifications	2
1.2.2	OS Support	4
1.2.3	Mechanical Specifications	4
1.2.4	Electrical Specifications	4
1.2.5	Environmental	4
1.3	Block Diagram	5
1.4	Board Layout: Dimensions	5
	Figure 1.1 MIO-5850 Mechanical Drawing (Top Side)	5
	Figure 1.2 MIO-5850 Mechanical Drawing (Bottom Side)	6
	Figure 1.3 MIO-5850 Mechanical Drawing (Coastline)	6
Chapter 2	Installation.....	7
2.1	Jumpers & Switches.....	8
	Table 2.1: Jumpers & Switches	8
2.2	Connectors.....	8
	Table 2.2: Connectors	8
2.3	Locating Connectors	9
	Figure 2.1 MIO-5850 Connector Locations (Top Side).....	9
	Figure 2.2 MIO-5850 Connector Locations (Bottom Side).....	9
2.4	Setting Jumpers	10
	Table 2.3: Clear CMOS (J1)	10
2.4.1	Auto Power On Setting (J2)	10
	Table 2.4: Auto Power On Setting (J2).....	10
2.4.2	LCD Power (J4)	10
	Table 2.5: LCD Power (J4)	11
2.4.3	LVDS VCON Setting (J5).....	11
	Table 2.6: LVDS VCON Setting (J5)	11
Chapter 3	AMI BIOS Setup	13
3.1	Entering Setup	15
3.1.1	Main Setup.....	15
3.1.2	Advanced BIOS Features Setup.....	16
3.1.3	Chipset Configuration	29
3.1.4	Security	36
3.1.5	Boot.....	37
3.1.6	Save & Exit	38
Chapter 4	Installation.....	39
4.1	Quick Installation Guide:	40
Appendix A	Pin Assignments	41
A.1	Jumper List.....	42
A.2	Connector Pin Definition	43

Appendix B	How to install Win7 64-bit	57
B.1	Purpose.....	58
B.2	Requirement:	58
B.3	Instruction	58
Appendix C	System Assignments.....	65
C.1	System I/O Ports.....	66
	Table C.1: System I/O Ports	66
C.2	1st MB Memory Map.....	66
	Table C.2: 1st MB Memory Map	66
C.3	Interrupt Assignments	66
	Table C.3: Interrupt assignments.....	66
Appendix D	EC Watchdog Timer Sample Code ..	67
D.1	EC Watchdog Timer sample code	68

Chapter 1

General Information

This chapter gives background information on the MIO-5850.

Sections include:

- Introduction
- Specifications
- Block diagram
- Board layout and dimensions

1.1 Introduction

MIO-5850 is first the 3.5" SBC with a CPU bottom side up design, powered by an Intel Celeron J1900, and Atom E3845/E3825. MIO-5850 is a specific design for domain focused applications in the Robotic/CNC industry. It has 3 LAN ports, CAN bus interface (2.5K ESD protection), 2GB/4GB memory on-board, 16GB/32GB/64GB eMMC on-board (optional), power input, 16-bit GPIO, M.2 key E /mini PCIe. MIO-5850 supports various display interface including VGA, HDMI and LVDS and rich I/O: SATA, mSATA, 4 x Serial Ports, 1 x USB 3.0, 5 x USB 2.0.

1.2 Specifications

1.2.1 Functional Specifications

■ Processor:

- Celeron® J1900 2.0GHz (burst frequency 2.42GHz), quad cores, four threads
- Atom™ E3845 1.91GHz, quad cores
- Atom™ E3825 1.33GHz, dual cores, two threads
- Cache Hierarchy
 - * 32 KB 8-way L1 instruction cache and 24 KB 6-way L1 data cache per core
 - * 1 MB, 16-way L2 cache, shared per two cores
- Supported C-states: C0, C1, C6, C7
- Advanced Technologies
 - * Intel® Virtualization Technology (VT-x)
 - * Intel® 64-bit architecture
 - * Enhanced Intel SpeedStep technology
 - * Intel® Trusted Execution Engine (TXE)
- Power Management
 - * ACPI 5.0
 - * System sleep states: S0, S3, S4, S5

■ System Memory Support

- Non-ECC
- 64-bit data bus
- x8 and x16 DDR3L SDRAM device data widths
- DDR3L with 1066 MT/s data rates for E3825, total memory bandwidth 8.5GB/s
- DDR3L with 1333 MT/s data rates for J1900/E3845, total memory bandwidth can be scalable to 21.3GB/s
- Aggressive power management to reduce power consumption

■ Graphic and Media Engine

- Intel® 7th generation (Gen 7) graphics and media encode/decode engine
- GFX: Normal 688 MHz / Burst 854 MHz for J1900/E3845, normal 533 MHz for E3825
- Graphic Features:
 - * 3D HW acceleration: DirectX11, OpenGL3.2, OpenCL1.2
 - * HW video decode: H.264, MPEG2, MVC, VC-1, WMV9, MJPEG and VP8
 - * HW video encode: H.264, (MPEG2 and MVC only for J1900)
- Multi-display interfaces: VGA, HDMI, 48-bit LVDS.
 - * Supports extend/ clone mode with multi-display device
 - * Dual display: any two combination between VGA, HDMI/DisplayPort/MIOe, DisplayPort, LVDS/eDP
- Specification and Resolution
 - * VGA: 2560 x 1600 at 60Hz

- * HDMI/DisplayPort: HDMI 1.4a with audio, up to 1080P at 60Hz.
- * LVDS: 48-bit dual channel LVDS up to WUXGA 1920x1200 at 60Hz via CH7511.
- * Inverter power: 1A @ 5V/12V
- 3D HW acceleration: OGL4.0, DirectX 11.1
- HW video decode: H.264, MPEG2, VC-1, VP8
- HW video encode: H.264, MPEG2 (max at 1080p)
- **Gigabit Ethernet**
 - Controller: Intel® i210
 - * 10/100/1000 BASE-T
 - * IEEE 802.3az Energy Efficient Ethernet (EEE), which defines Low Power Idle (LPI) state
 - * IEEE 1588/802.1AS precision time synchronization
 - * 9.5 KB jumbo frames supported (full-duplex)
 - * Flow control supported
 - * Magic packet wake-up enable with unique MAC address
- **Peripheral interface**
 - 1 Serial-ATA port, up to 3.0Gb/s transfer rate (300 MB/s), supports independent DMA operation
 - * SATA power: 5V / 12V
 - 1 x USB 3.0 & 5 x USB2.0
 - * One USB 3.0 and 1 USB 2.0 on rear I/O, 4 x internal USB2.0
 - * USB 3.0 SuperSpeed (SS), implements xHCI software host controller interface
 - * Multiplexed with EHCI controller that are High-Speed/Full-Speed (HS/FS)
 - * USB source: USB 3.0 and USB 2.0's dual port on rear I/O's USB signal directly from CPU, 4 x USB 2.0 from USB hub.
 - * Supports wake-up from sleeping state S3
 - * Power supply: 0.5A @ 5V for USB2.0, 1A @ 5V for USB3.0
 - 2 RS232/422/485 for COM1/2, 2 RS232 for COM3/4 (ESD protection: air gap ±15kV, contact ±8kV)
 - 8-bit programmable general purpose input/ output from iManager (5V tolerance)
 - 1 SMBus / I²C channel from iManager
 - Watchdog timer: Output system reset, programmable counter from 1 ~ 255 minutes/ seconds
 - Mini PCIe / mSATA
 - * 1 Full-size Mini PCIe with SIM holder (with PCIe and USB interface)
 - * 1 Half size mSATA (with SATA and USB interface)
 - * Power supply: 1.1 A @ 3.3 V, 0.375 A @ 1.5 V
 - M.2 E Key
- **High Definition Audio:**
 - Intel® High Definition Audio Interface
 - High definition audio codec with Realtek proprietary loss-less content protection technology
 - Supports 1 Line-input, 1 Line output, 1 Mic-input
- **BIOS**
 - AMI UEFI 64 Mbit, BIOS for 64 or 32-bit is different, default version is for 6-bit
 - Default setting is legacy boot, that can be manually changed to UEFI boot. If default setting to UEFI is needed, that can be done by T-P/N

1.2.2 OS Support

MIO-5850 supports Win8, Win7, WES8, WES7, WEC7.

For further information about OS support of MIO-5850, please Advantech website: <http://support.advantech.com.tw/> or contact the technical support center.

1.2.3 Mechanical Specifications

- **Dimensions:** 146 x 102 mm (5.7 x 4 inches)
- **Height:** Top side 19mm, PCB 1.6mm, bottom side 6.8mm, total 27.4mm
- **Weight:** 0.5 kg (reference weight of total package)

1.2.4 Electrical Specifications

- **Power Requirement:** Single +12V DC \pm 10% power input
- **Power Consumption:**
 - Max load
 - MIO-5850J-U0A1E: 1.74A @12V (20.88W)
 - MIO-5850J-U0A1E: 3.57A @24V (85.68W)
 - Idle mode
 - MIO-5850J-U0A1E: 0.63A @12V (7.56W)
 - MIO-5850J-U0A1E: 0.60@24V (14.4W)
- **Power Consumption Conditions:**
 - Test software: 3DMark 2006
 - Max. load: Measure the maximum current value which system under maximum load (CPU: top speed, RAM & graphic: full loading)
 - Idle mode: Measure the current value when system in windows mode and without running any program
- **RTC Battery:**
 - Typical Voltage: 3.0 V
 - Normal discharge capacity: 210 mAh

1.2.5 Environmental

- **Operating Temperature:** 0 ~ 60°C (32 ~ 140°F), extended: -40 ~ 85° C (-40 ~ 185° F)
- **Operating Humidity:** 40°C @ 85% RH Non-condensing
- **Storage Temperature:** Storage temperature: -40~85°C
- **Storage Humidity:** Relative humidity: 95% @ 60°C

1.3 Block Diagram

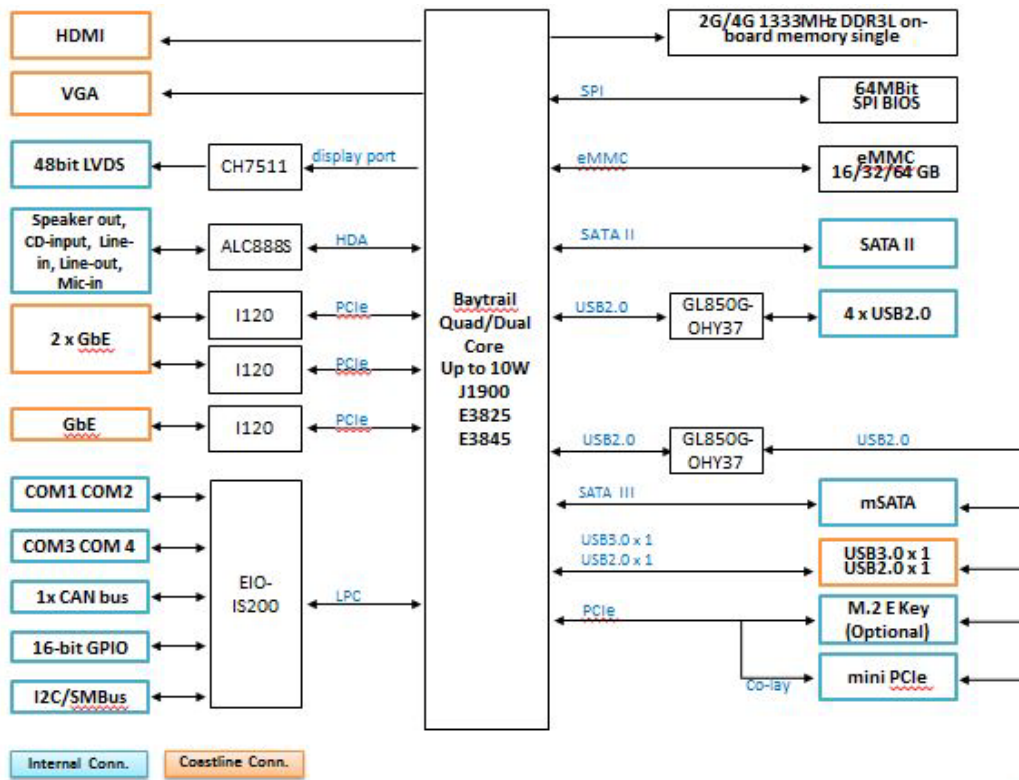

1.4 Board Layout: Dimensions

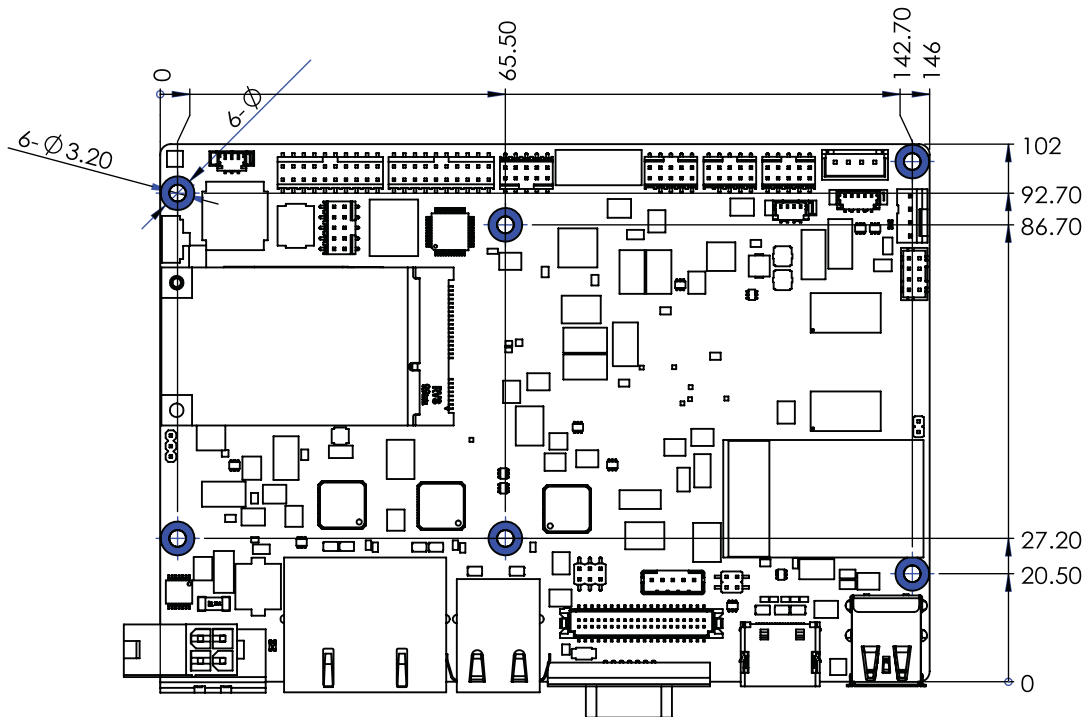

Figure 1.1 MIO-5850 Mechanical Drawing (Top Side)

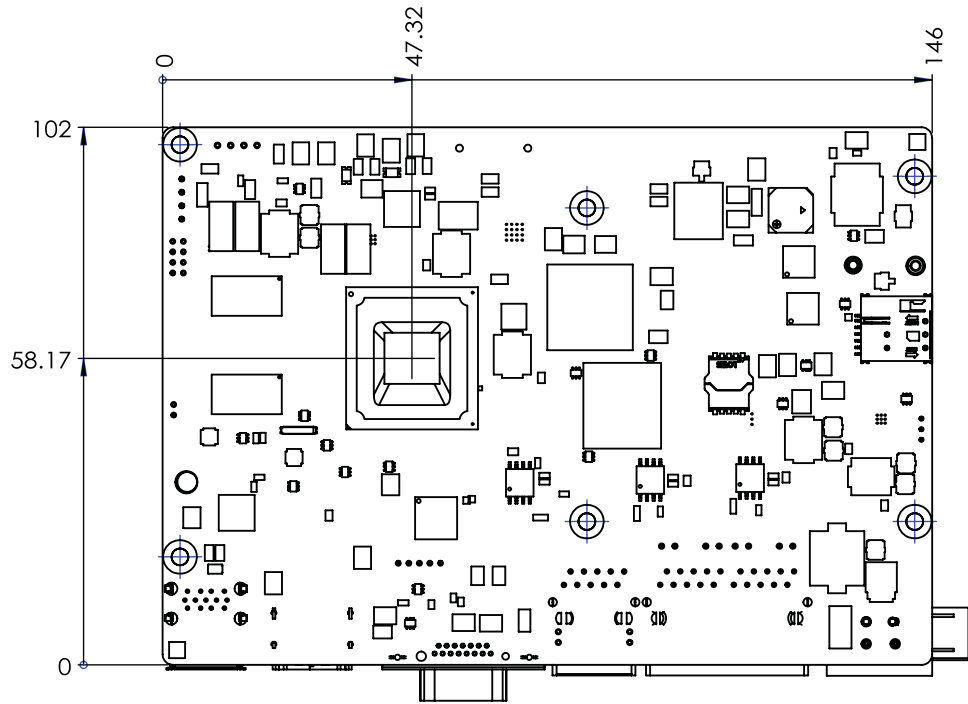

Figure 1.2 MIO-5850 Mechanical Drawing (Bottom Side)

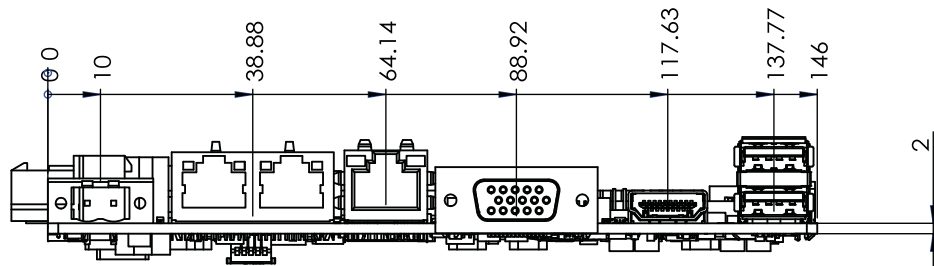

Figure 1.3 MIO-5850 Mechanical Drawing (Coastline)

Chapter 2

Installation

This chapter explains the setup procedures of the MIO-5850 hardware, including instructions on setting jumpers and connecting peripherals, switches and indicators. Be sure to read all safety precautions before you begin the installation procedure.

2.1 Jumpers & Switches

The MIO-5850 has a number of jumpers that allow you to configure your system to suit your application. The table below lists the functions of the various jumpers.

Table 2.1: Jumpers & Switches

J1	Clear CMOS
J2	Auto Power on Setting
J4	LCD power
J5	LVDS VCON Setting

2.2 Connectors

Onboard connectors link the MIO-5850 to external devices such as hard disk drives, a keyboard, or floppy drives. The table below lists the function of each of the connectors.

Table 2.2: Connectors

Label	Function
CN1	M.2 E-key
CN2	RTC Battery
CN3	CAN Bus
CN4	SATA Power
CN6	Front Panel
CN7	SATA
CN8	Internal USB
CN9	Internal USB
CN10	COM1/COM2/RS232/RS422/RS485
CN11	COM3/COM4/RS232
CN12	I2C
CN13	SM Bus
CN14	FAN
CN16	Audio
CN17	GPIO_P0
CN18	GPIO_P1
CN19	mSATA
CN20	MINIPCI Express
CN22	Inverter Power output
CN23	RJ45
CN24	RJ45
CN25	48-bit LVDS
CN26	USB2.0+3.0
CN28	HDMI
CN29	Power Input
CN31	VGA
CN32	NAMO SIM

2.3 Locating Connectors

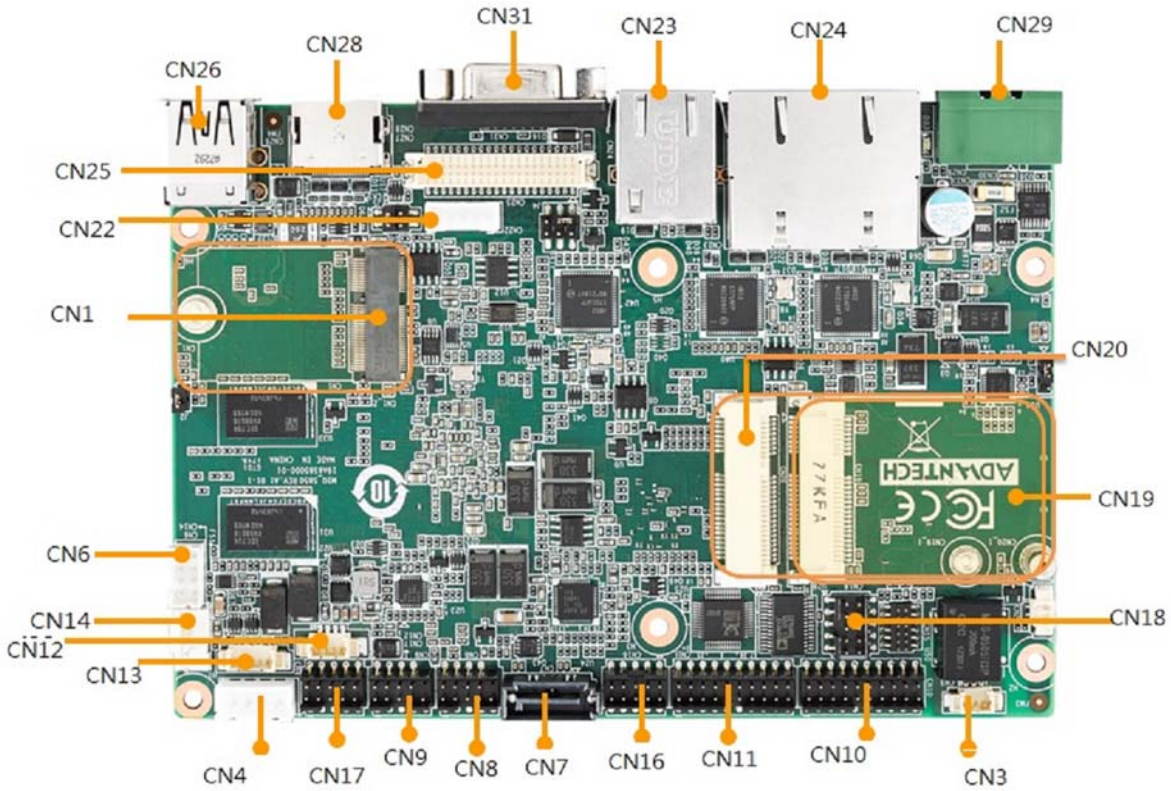

Figure 2.1 MIO-5850 Connector Locations (Top Side)

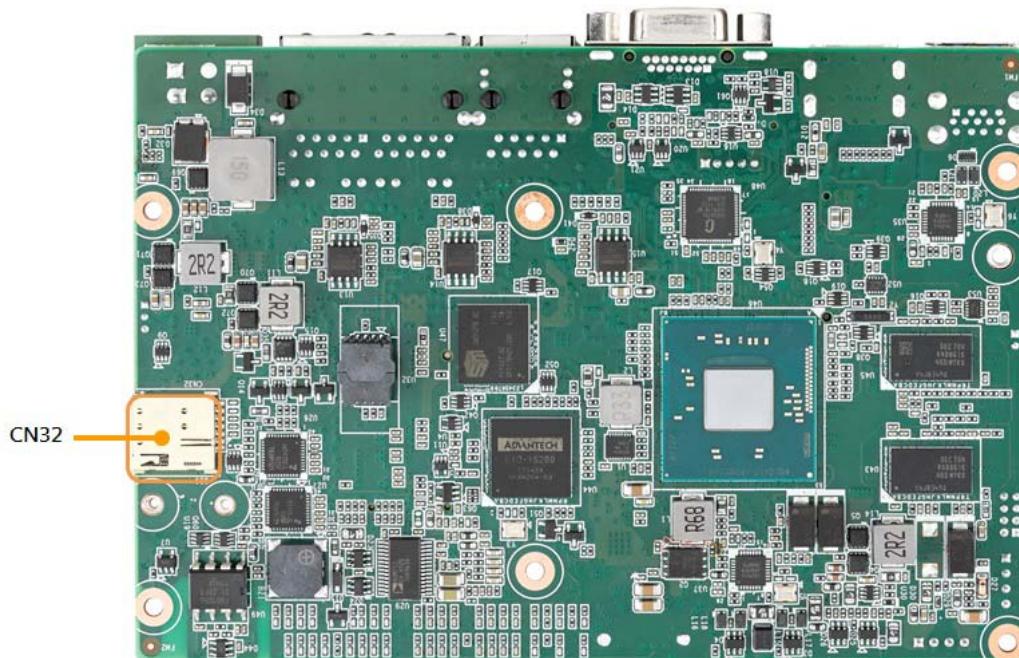
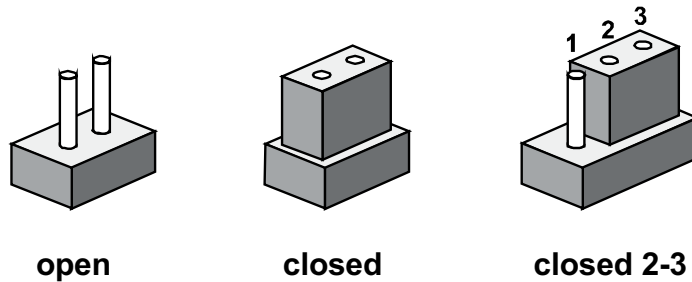

Figure 2.2 MIO-5850 Connector Locations (Bottom Side)

2.4 Setting Jumpers

You may configure your card to match the needs of your application by setting jumpers. A jumper is a metal bridge used to close an electric circuit. It consists of two metal pins and a small metal clip (often protected by a plastic cover) that slides over the pins to connect them. To “close” a jumper, you connect the pins with the clip. To “open” a jumper, you remove the clip. Sometimes a jumper will have three pins, labeled 1, 2 and 3. In this case you would connect either pins 1 and 2, or 2 and 3.

The jumper settings are schematically depicted in this manual as follows:



A pair of needle-nose pliers may be helpful when working with jumpers. If you have any doubts about the best hardware configuration for your application, contact your local distributor or sales representative before you make any changes. Generally, you simply need a standard cable to make most connections.

Table 2.3: Clear CMOS (J1)

Setting	Function
(1-2)*	Normal
(2-3)	Clear COMS

2.4.1 Auto Power On Setting (J2)



Table 2.4: Auto Power On Setting (J2)

Setting	Function
NC	Power Button for Power On
(1-2)*	Auto Power On

* Default

2.4.2 LCD Power (J4)

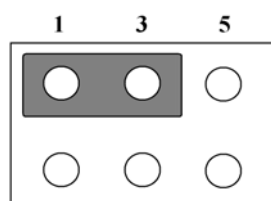
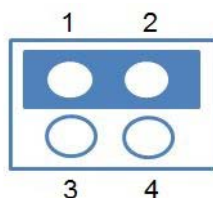

Table 2.5: LCD Power (J4)

Setting	Function
(1-3)*	+3.3V
(3-5)	+5V
(3-4)	+12V

2.4.3 LVDS VCON Setting (J5)

**Table 2.6: LVDS VCON Setting (J5)**

Setting	Function
(1-2)*	3.3V High for VCON on LVDS
(1-3)	Low for VCON on LVDS

Chapter 3

AMI BIOS Setup

With the AMIBIOS Setup program, you can modify BIOS settings and control the various system features. This chapter describes the basic navigation of the MIO-5850 BIOS setup screens.



AMI BIOS ROM has a built-in Setup program that allows users to modify the basic system configuration. This information is stored in battery-backed CMOS so it retains the Setup information when the power is turned off.

3.1 Entering Setup

Turn on the computer and check for the patch code. If there is a number assigned to the patch code, it means that the BIOS supports your CPU. If there is no number assigned to the patch code, please contact an Advantech application engineer to obtain an up-to-date patch code file. This will ensure that your CPU's system status is valid. After ensuring that you have a number assigned to the patch code, press and you will immediately be allowed to enter Setup.

3.1.1 Main Setup

When you first enter the BIOS Setup Utility, you will encounter the Main setup screen. You can always return to the Main setup screen by selecting the Main tab. There are two Main Setup options. They are described in this section. The Main BIOS Setup screen is shown below.

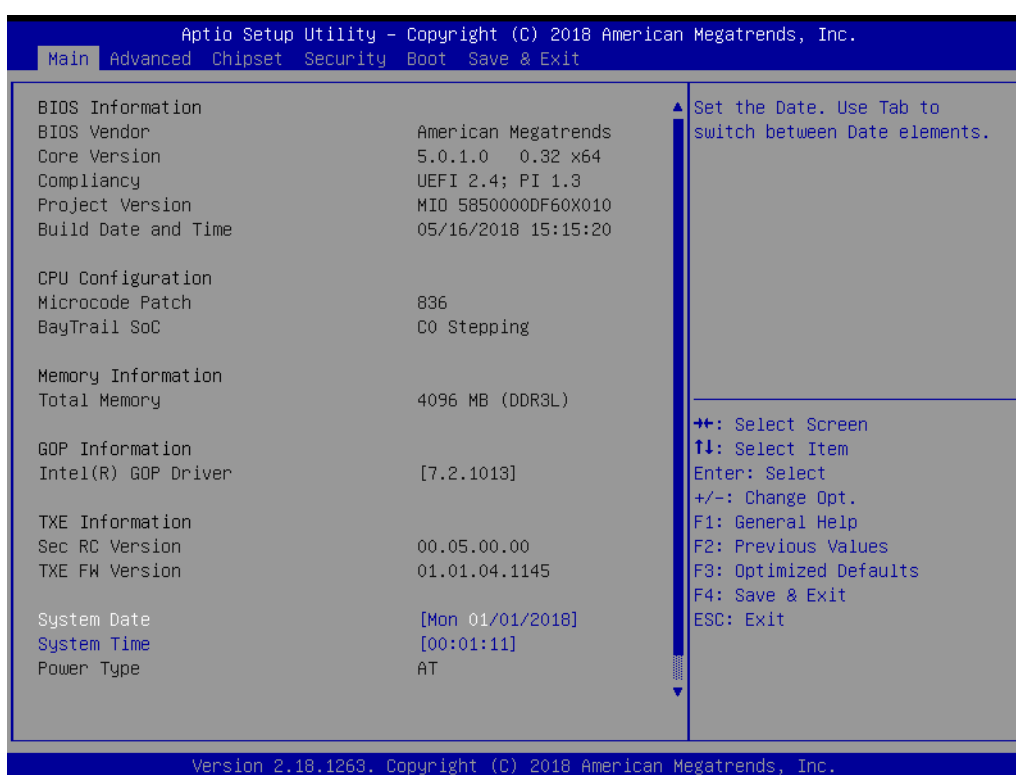

The Main BIOS setup screen has two main frames. The left frame displays all the options that can be configured. Grayed-out options cannot be configured; options in blue can. The right frame displays the key legend.

Above the key legend is an area reserved for a text message. When an option is selected in the left frame, it is highlighted in white. Often a text message will accompany it.

■ System time / System date

Use this option to change the system time and date. Highlight System Time or System Date using the <Arrow> keys. Enter new values through the keyboard.

Press the <Tab> key or the <Arrow> keys to move between fields. The date must be entered in MM/DD/YY format. The time must be entered in HH:MM:SS format.

3.1.2 Advanced BIOS Features Setup

Select the Advanced tab from the MIO-5251 setup screen to enter the Advanced BIOS Setup screen. You can select any of the items in the left frame of the screen, such as CPU Configuration, to go to the sub menu for that item. You can display an Advanced BIOS Setup option by highlighting it using the <Arrow> keys. All Advanced BIOS Setup options are described in this section. The Advanced BIOS Setup screens is shown below. The sub menus are described on the following pages.

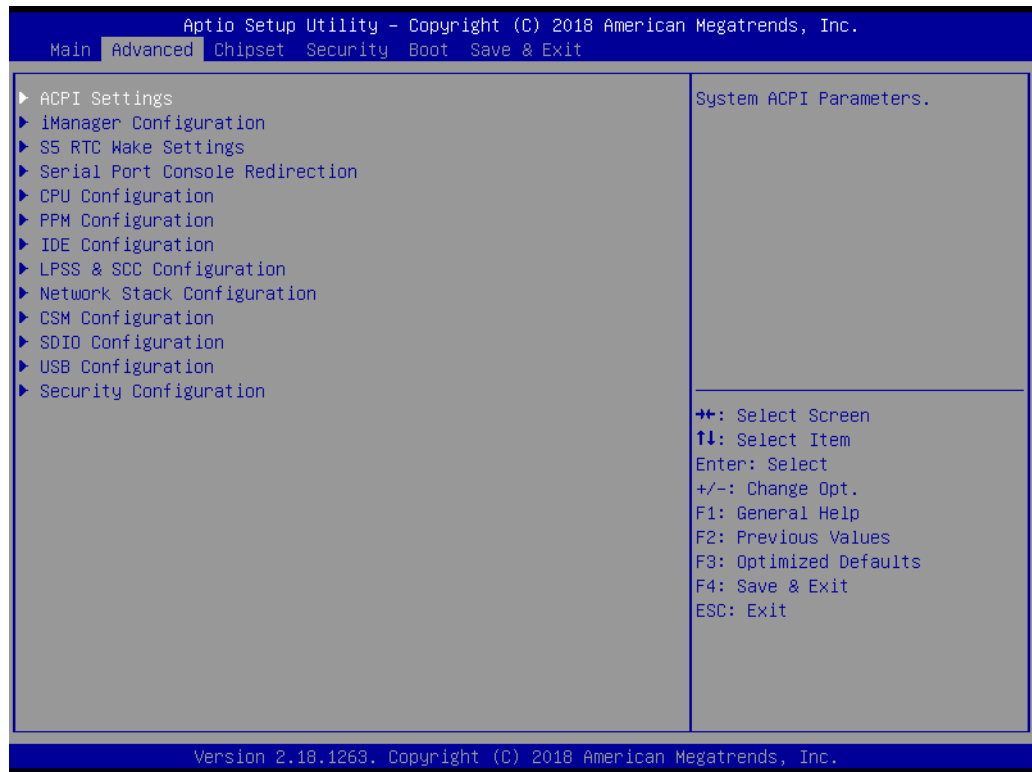

3.1.2.1 ACPI Settings

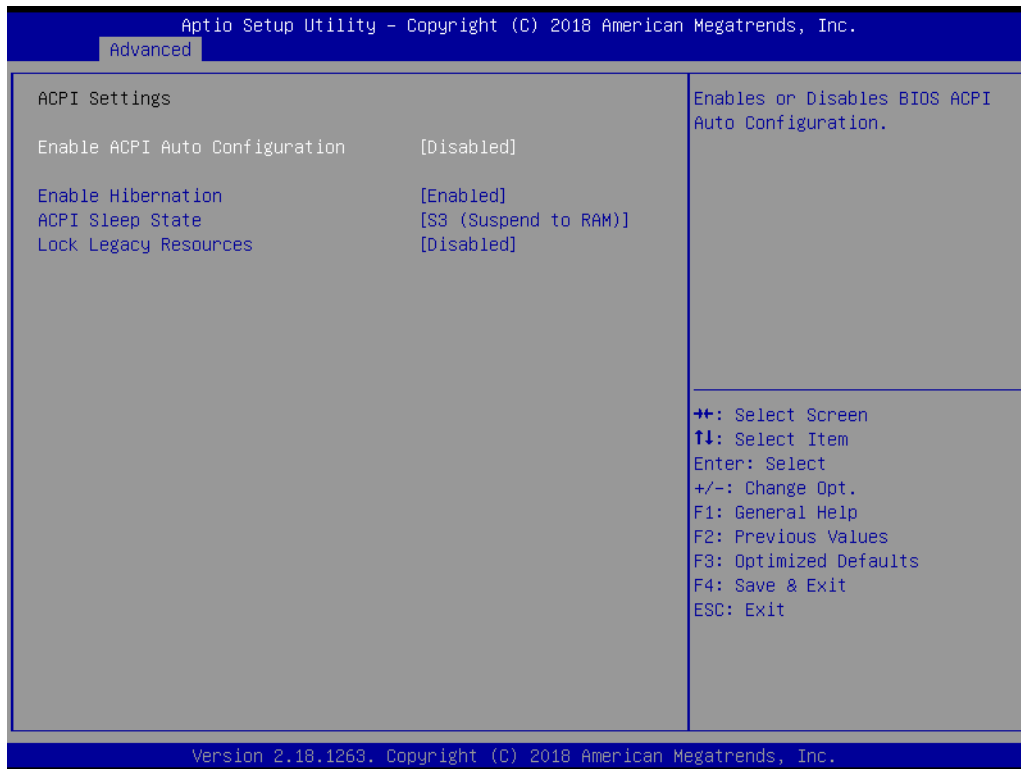

- **Enable ACPI Auto Configuration**
Enables or disables BIOS ACPI auto configuration.
- **Enable Hibernation**
Enables or disables system ability to hibernate (OS/S4 sleep state). This option may not be effective with some OS.
- **ACPI Sleep State**
Selects the highest ACPI sleep state the system will enter when the SUSPEND button is pressed.
- **Lock Legacy Resources**
Enables or disables Lock of Legacy Resources

3.1.2.2 iManager Configuration

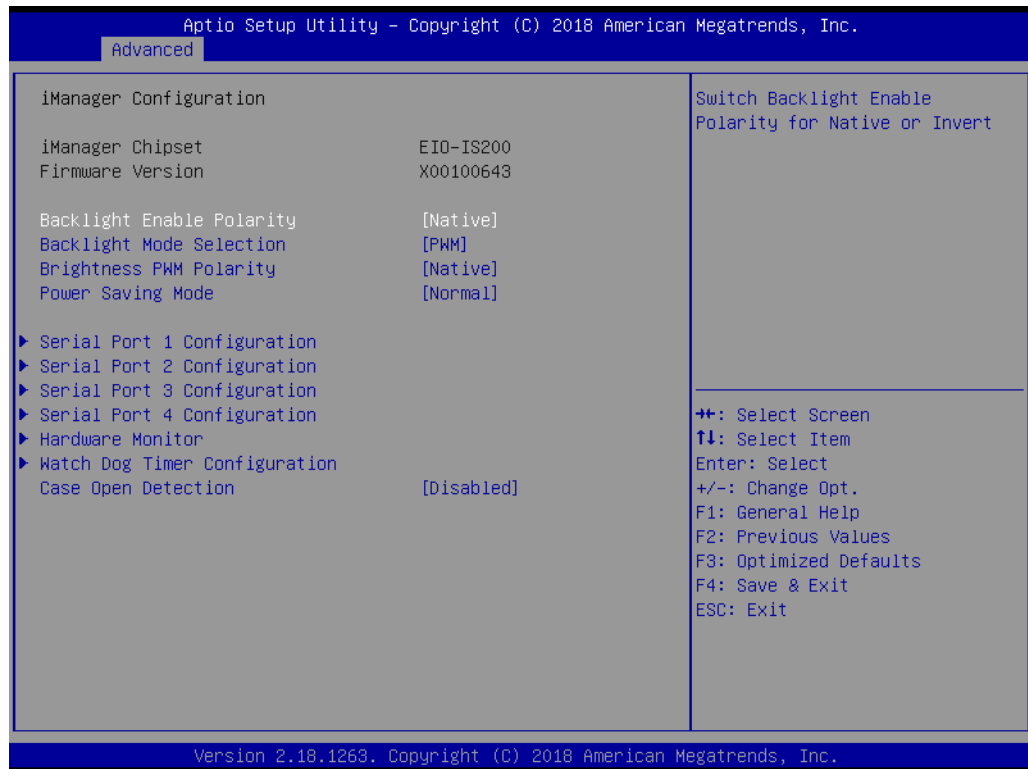

- **Backlight Enable Polarity**
Switch Backlight Enable Polarity for Native or Invert.
- **Backlight Mode Selection**
Switch Backlight Control to PWM or DC mode.
- **Brightness PWM Polarity**
Switch backlight control Brightness PWM Polarity for native or invert.
- **Power Saving Mode**
This item allows users to set board's power saving mode when off.
- **Serial Port 1 Configuration**
Set Parameters of Serial Port 1 (COMA).
- **Serial Port 2 Configuration**
Set Parameters of Serial Port 2 (COMB).
- **Serial Port 3 Configuration**
Set Parameters of Serial Port 3 (COMC).
- **Serial Port 4 Configuration**
Set Parameters of Serial Port 4 (COMD).
- **Hardware Monitor**
Monitor hardware statue.
- **Watch Dog Timer Configuration**
Watch Dog Timer Configuration page.
- **Case Open Detection**
Enables or disables Case Open Detect function.

HW Monitor

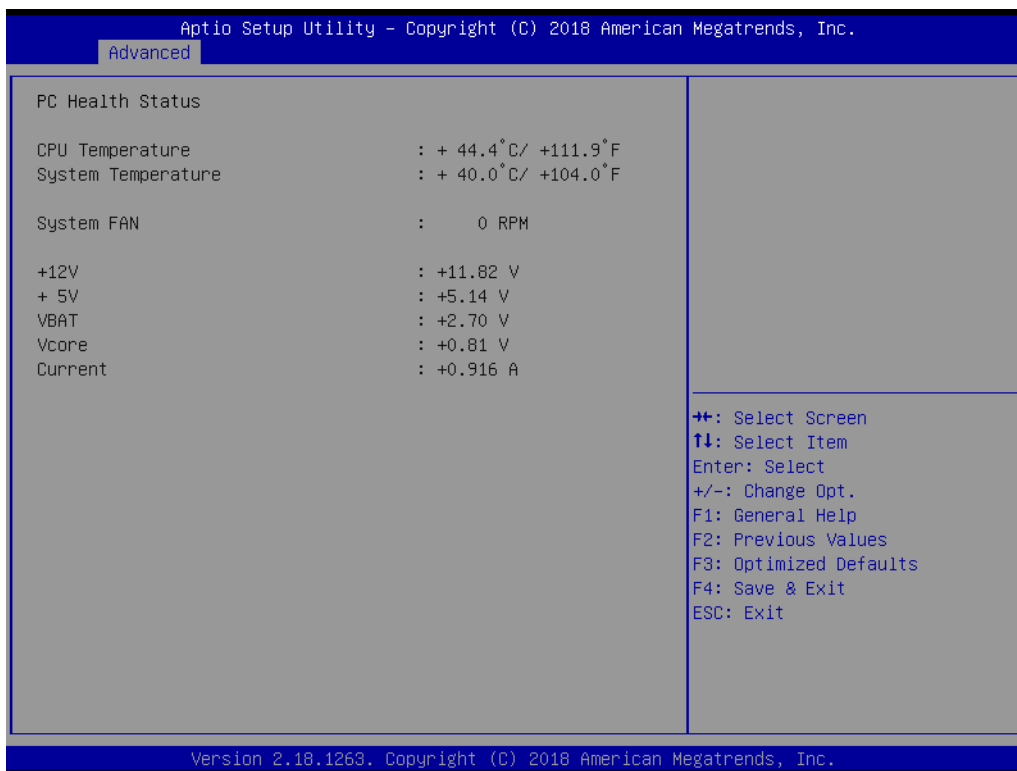

■ PC Health Status

This page displays all information about system Temperature/Voltage.

Watch Dog Timer Configuration



- **Watch Dog Timer**

This page displays all information about Watch Dog Timer Configuration.

3.1.2.3 S5 RTC Wake Settings

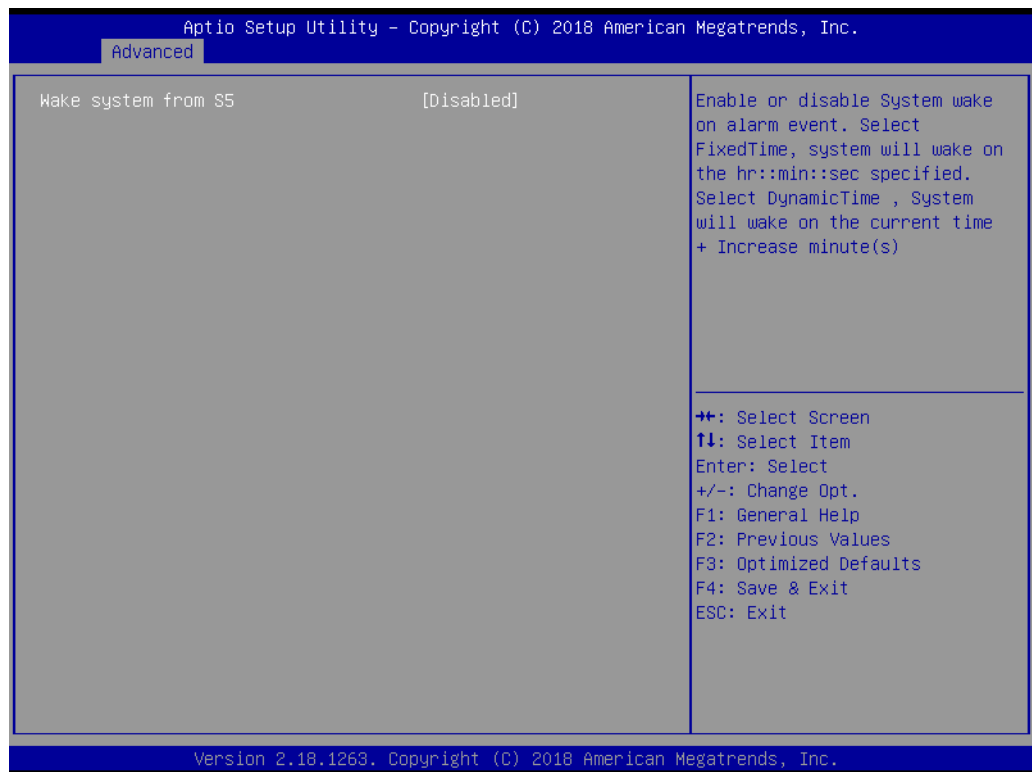

- **Wake system from S5**

Enable or disable System wake on alarm event. Select FixedTime, system will wake on the hr:min:sec specified.

3.1.2.4 Serial Port Console Redirection

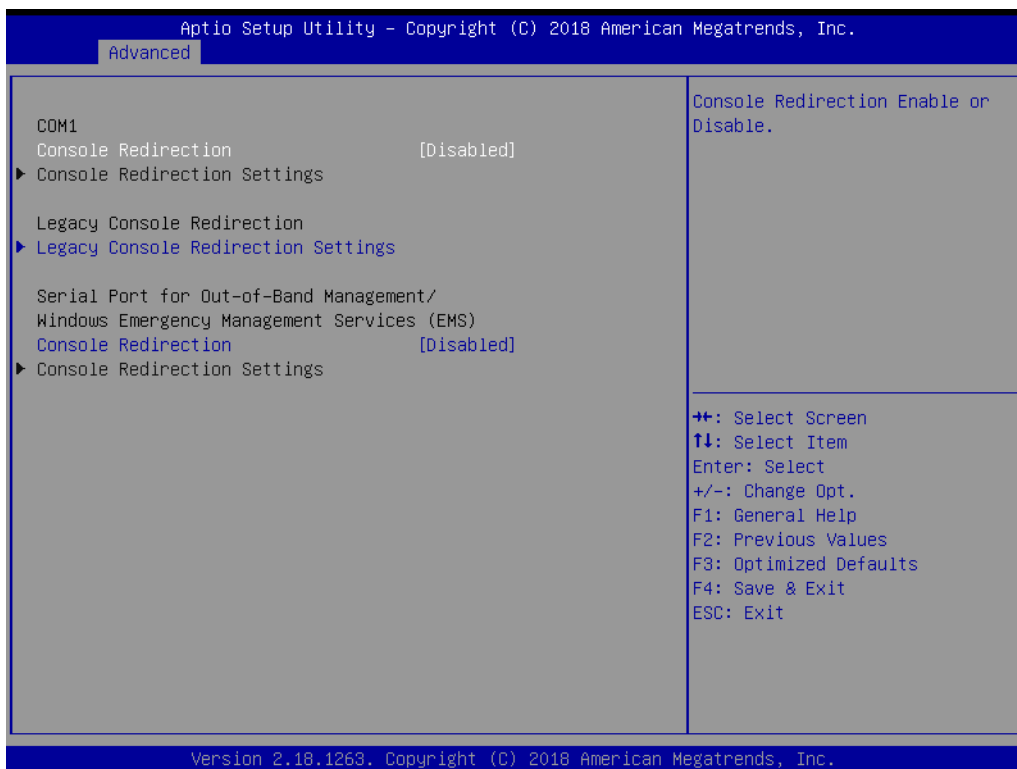

- **Console Redirection**
This item allows users to enable or disable console redirection for Microsoft Windows Emergency Management Services (EMS).
- **Console Redirection**
This item allows users to configuration console redirection detail settings.

3.1.2.5 CPU Configuration

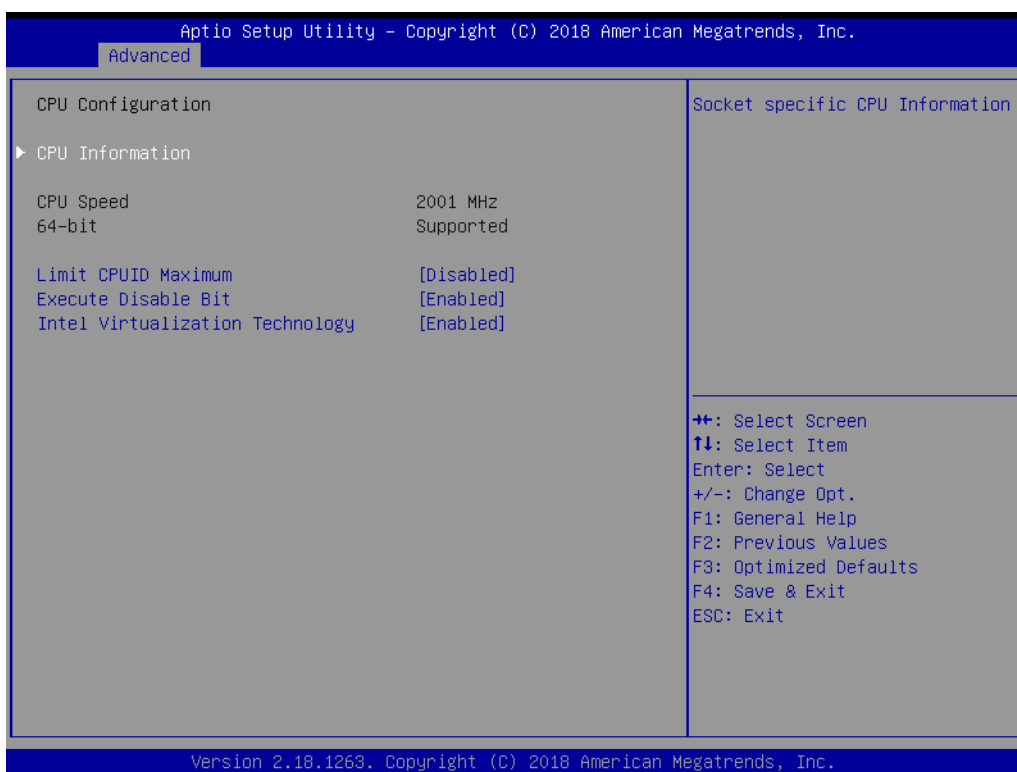

- **Limit CPUID Maximum**
Disabled for Windows XP.
- **Execute Disable Bit**
When XD can prevent certain classes of malicious buffer overflow attacks when combined with a supporting OS (Windows Server 2003 SP1, Windows XP SP2, SuSE Linux 9.2, RedHat Enterprise 3 update 3.).
- **Intel Virtualization Technology**
When enabled, a VMM can utilize the additional hardware capabilities provided by Vanderpool Technology.

3.1.2.6 PPM Configuration



- **CPU C state Report**
Enable or disable CPU C state report to OS.

3.1.2.7 IDE Configuration

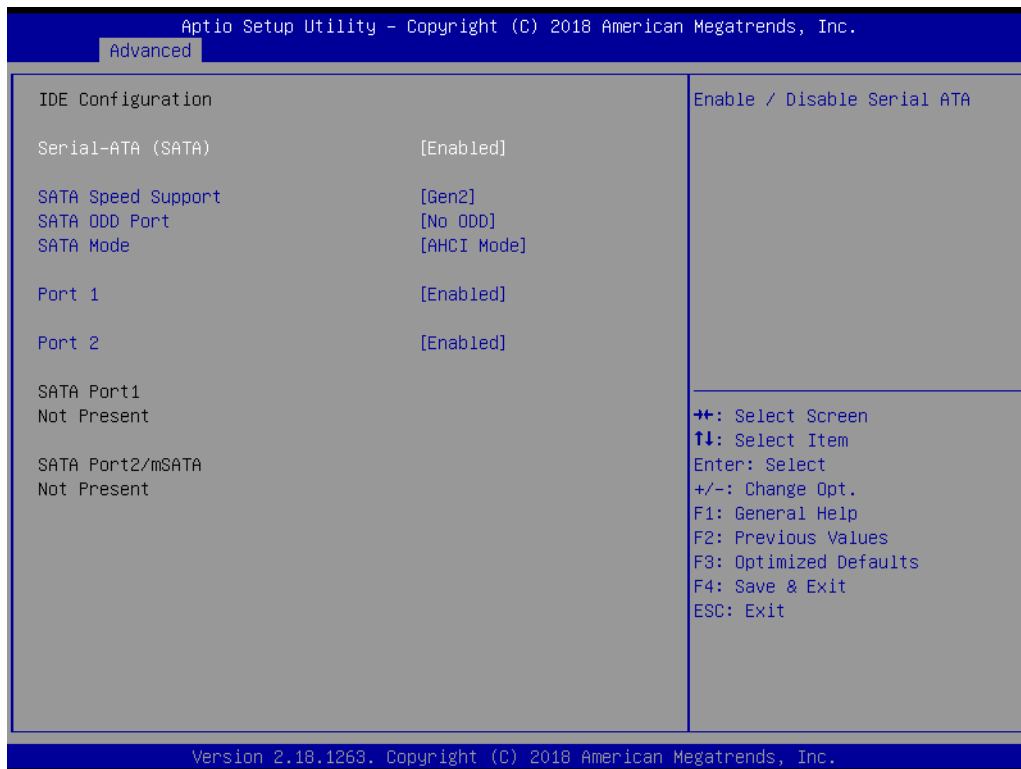

- **Serial-ATA (SATA)**
Enable / Disable Serial ATA.
- **SATA Speed Support**
SATA Speed Support Gen1 or Gen2.
- **SATA ODD Port**
SATA ODD is Port 0 or Port 1.
- **SATA Mode**
Select IDE / AHCI.
- **Serial-ATA Port 0**
Enable / Disable Serial ATA Port 0.
- **Serial-ATA Port 1**
Enable / Disable Serial ATA Port 1.

3.1.2.8 LPSS & SCC Configuration



- **LPSS & SCC Devices Mode**
LPSS & SCC Devices Mode Settings.
- **SCC eMMC Support**
Enable or disable SCC eMMC support.
- **eMMC Secure Erase**
Enable or disable eMMC Secure Erase. When enabled, all the data on eMMC will be erased.
- **SCC SDIO Support**
Enable or disable SCC SDIO support.
- **LPSS HSUART #1 Support**
Enable or disable LPSS HSUART #1 support.

3.1.2.9 Network Stack Configuration



- **Network Stack**
Enable or disable UEFI Network Stack.

3.1.2.10 CSM Configuration

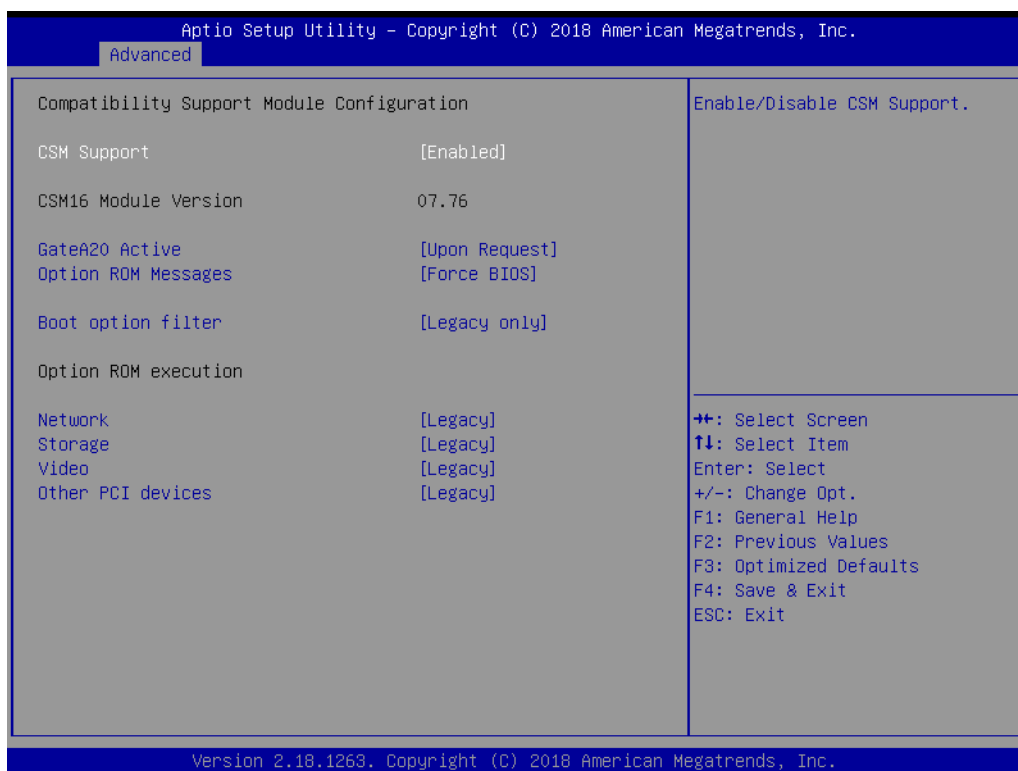

- **CSM Support**
Enable or disable CSM Support.
- **GateA20 Active**

UPON REQUEST - GA20 can be disabled using BIOS services. Do not allow disabling of GA20; this option is useful when any RT code is executed above 1MB.

- **Option ROM Messages**
Set display mode for Option ROM.
- **Boot option filter**
This option controls Legacy/UEFI ROM priority.
- **Network**
Controls the execution of UEFI and Legacy PXE OpROM.
- **Storage**
Controls the execution of UEFI and Legacy Storage OpROM.
- **Video**
Controls the execution of UEFI and Legacy Video OpROM.
- **Other PCI devices**
Determines OpROM execution policy for devices other than Network, Storage, or Video.

3.1.2.11 SDIO Configuration



- **SDIO Access Mode**
Auto Option: Access SD device in DMA mode if controller supports it, otherwise in PIO mode.

3.1.2.12 USB Configuration

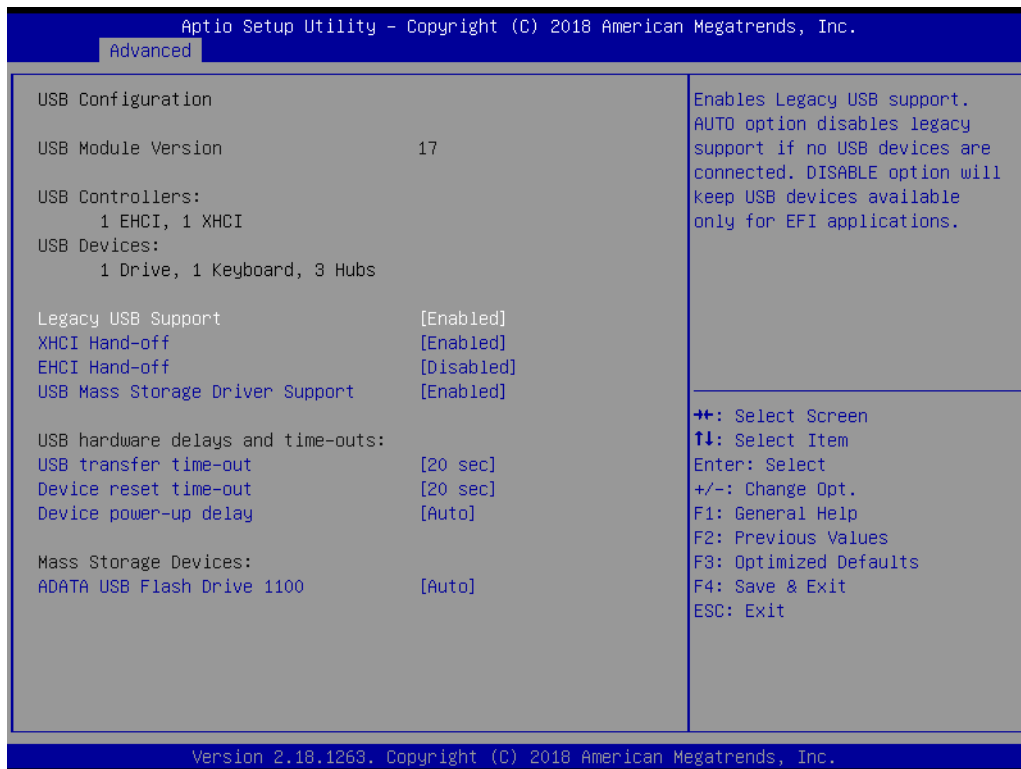

- **Legacy USB Support**
Enables Legacy USB Support. AUTO option disables legacy support if no USB devices are connected. DISABLE option will keep USB devices available only for EFI applications.
- **XHCI Hand-off**
This is a workaround for OS without XHCI hand-off support. The XHCI ownership change should be claimed by XHCI driver.
- **EHCI Hand-off**
This is a workaround for OS without EHCI hand-off support. The EHCI ownership change should be claimed by EHCI driver.
- **USB Mass Storage Driver Support**
Enable or disable USB Mass Storage Driver Support.
- **USB transfer time-out**
Time-out value for control, bulk, and interrupt transfers.
- **Device reset time-out**
USB mass storage device start unit command time-out.
- **Device power-up delay**
Maximum time the device will take before it properly reports itself to the Host Controller. 'Auto' uses default value: for a Root port it is 100 ms, for a Hub port the delay is taken from Hub descriptor.

3.1.2.13 Security Configuration

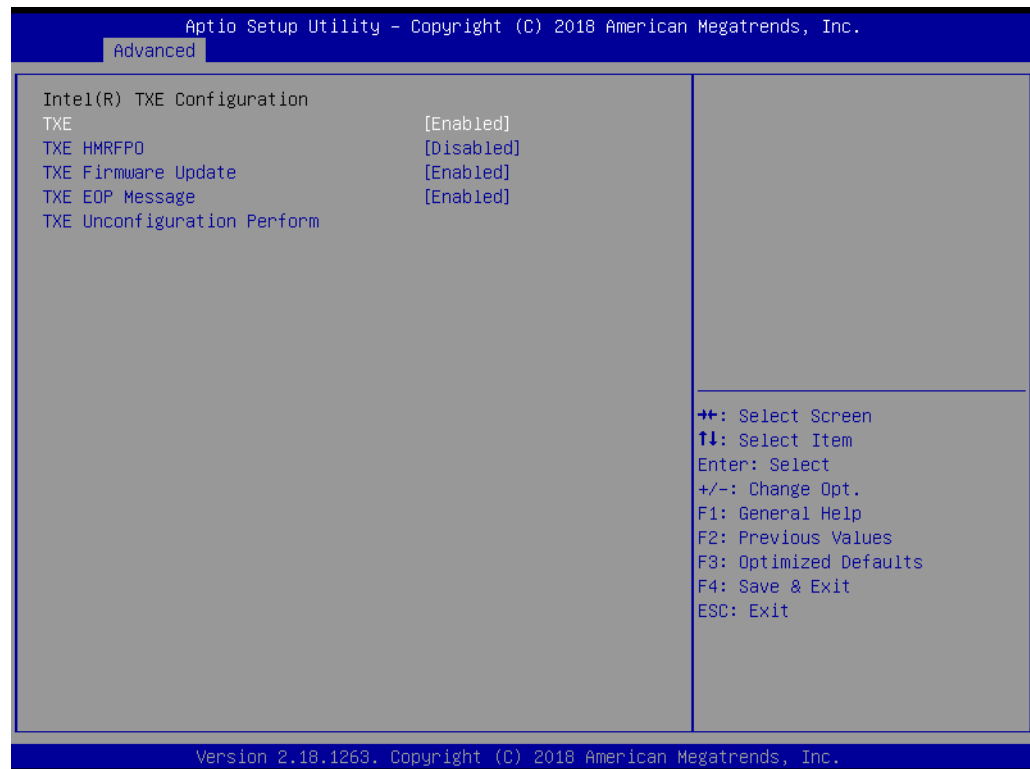

- **TXE HMRFPD Disable**
- **TXE Firmware Update**
- **TXE EOP Message**
Send EOP Message before entering the OS
- **TXE Unconfiguration Perform**
Revert TXE setting to factory defaults.

3.1.3 Chipset Configuration

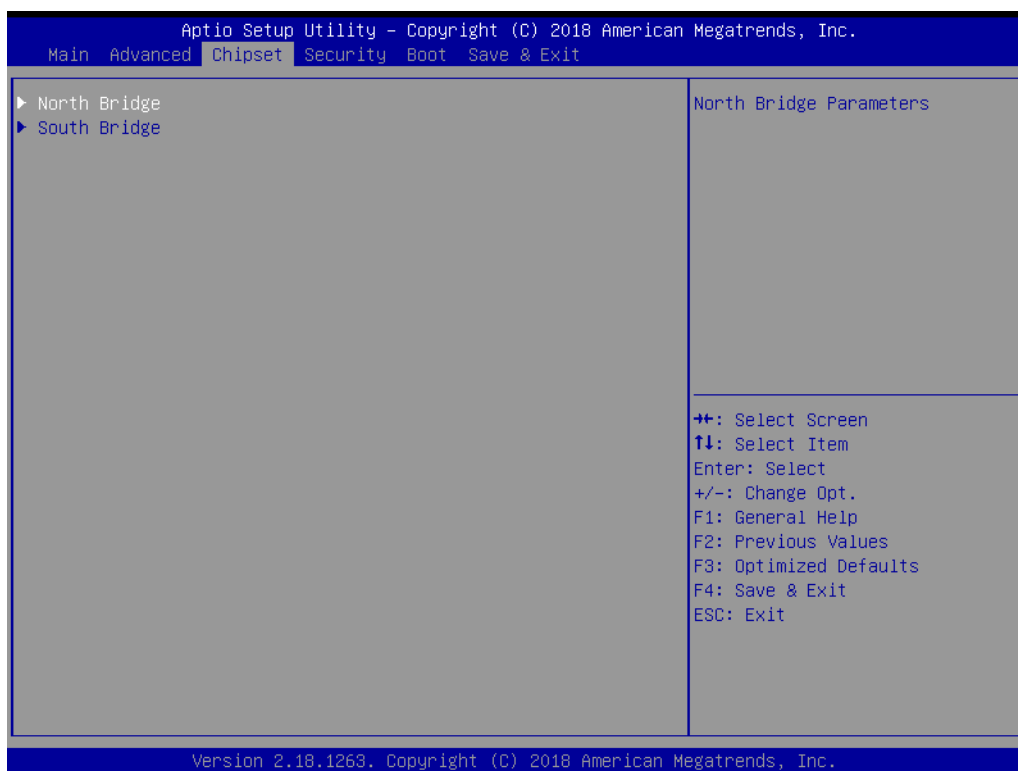

- **North Bridge**
Details for North Bridge items.
- **South Bridge**
Details for South Bridge items.

3.1.3.1 North Bridge

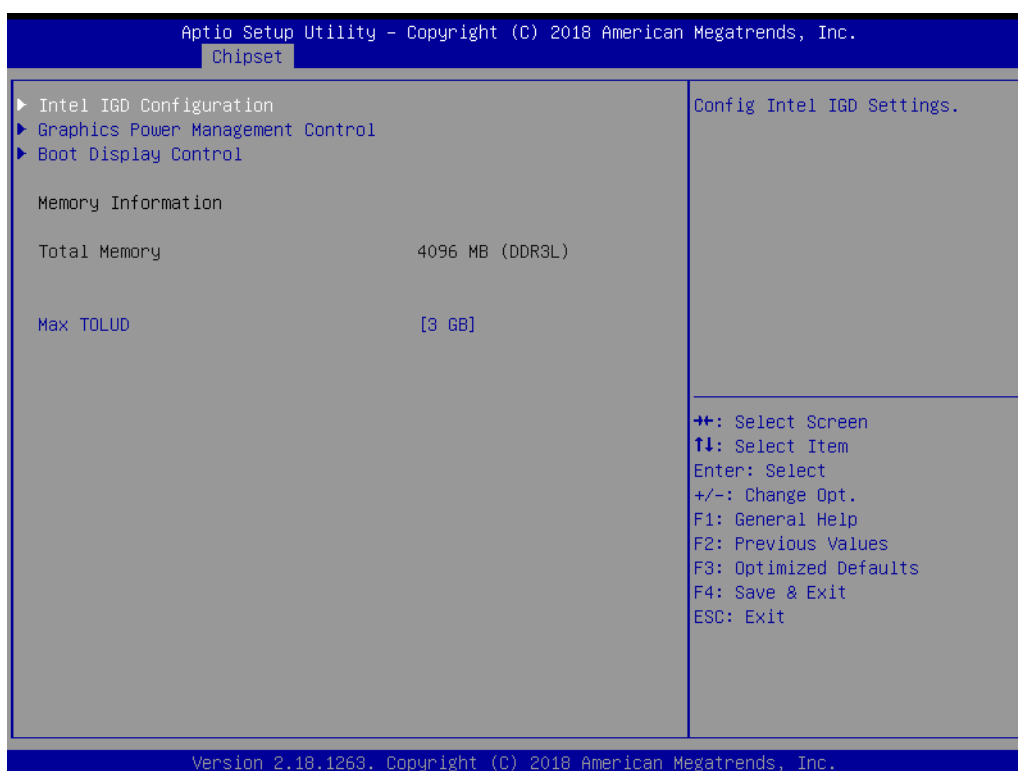

- **Intel IGD Configuration**
Config Intel IGD settings.
- **Graphics Power Management Control**
Graphics Power Management Control options.
- **Boot Display Control**
LCD Control.
- **Max TOLUD**
Maximum Value of TOLUD.

3.1.3.2 Intel IGD Configuration

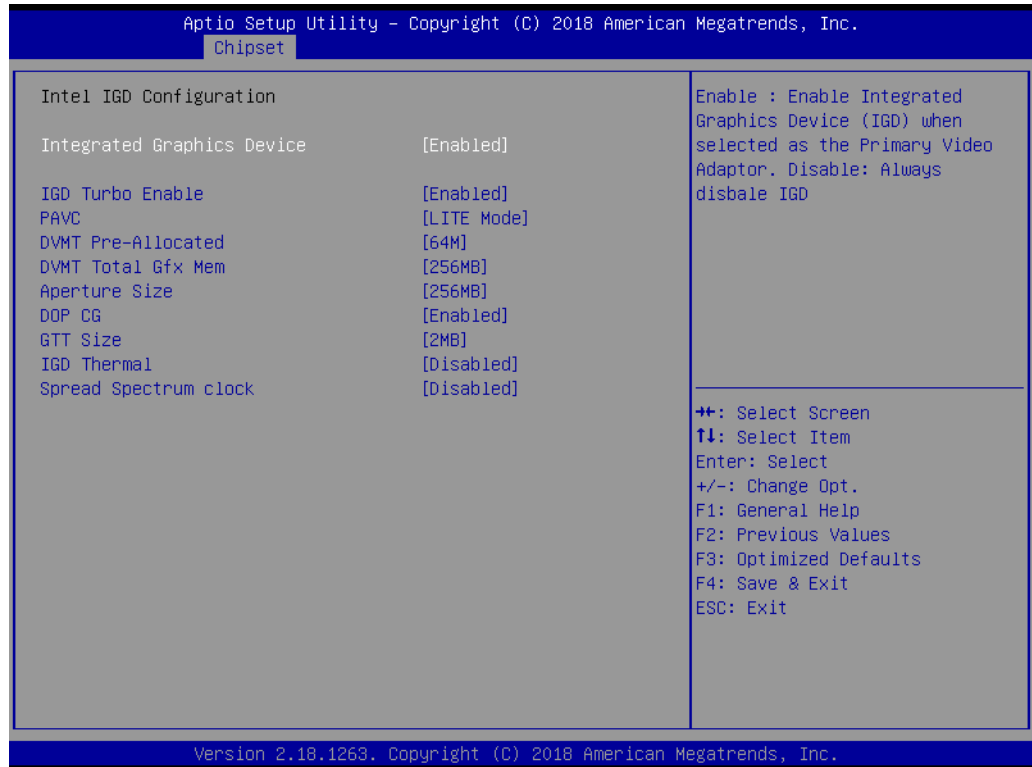

- **Integrated Graphics Device**
Enable: Enable Integrated Graphics Device (IGD) when selected as Primary Video Adaptor. Disable: Always disable IGD.
- **IGD Turbo Enable**
Enable: IGD Turbo Enable. Disable: IGD Turbo Disable.
- **PAVC**
Enable or disable Protected Audio Video Control.
- **DVMT Pre-Allocated**
Select DVMT 5.0 Pre-Allocated (Fixed) Graphics Memory size used by the Internal Graphics Device.
- **DVMT Total Gfx Mem**
Select DVMT 5.0 total graphic memory size used by the Internal graphics device.
- **Aperture Size**
Select the Aperture Size.
- **DOP CG**
Enable or disable DOP Clock Gating.
- **GTT Size**

- Select the GTT size
- **IGD Thermal**
Enable or disable IGD Thermal.
- **Spread Spectrum clock**
Enable or disable Spread Spectrum clock.

3.1.3.3 Graphics Power Management Control

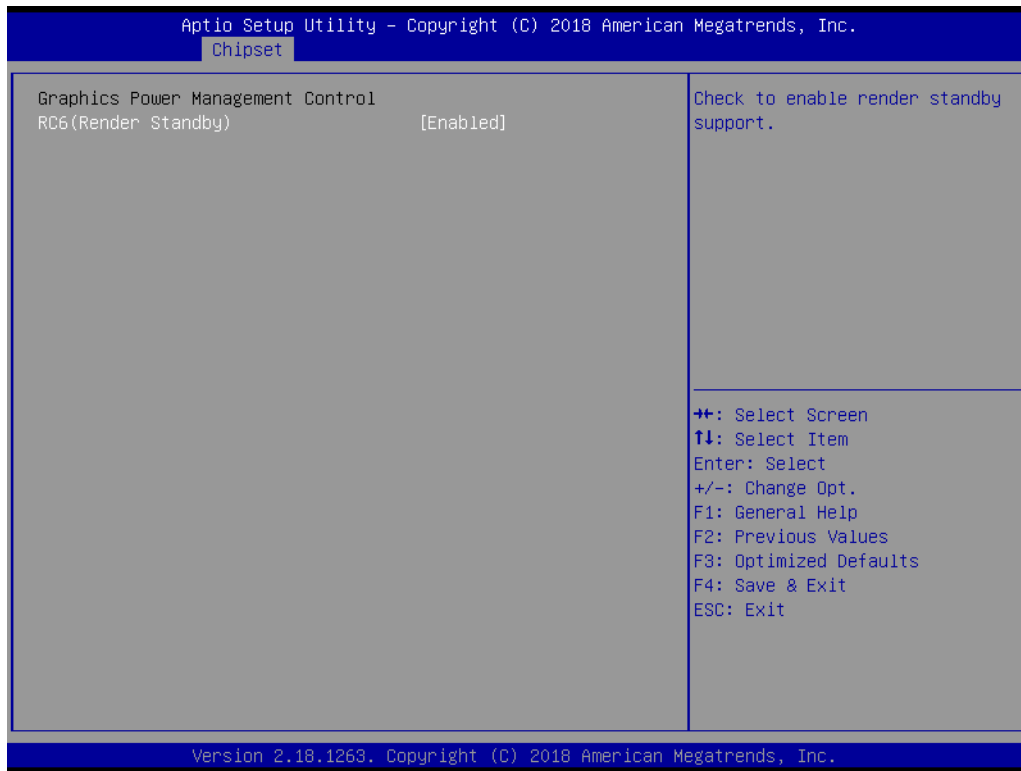

- **RC6 Render Standby)**
Check to enable render standby support.

3.1.3.4 Boot Display Control

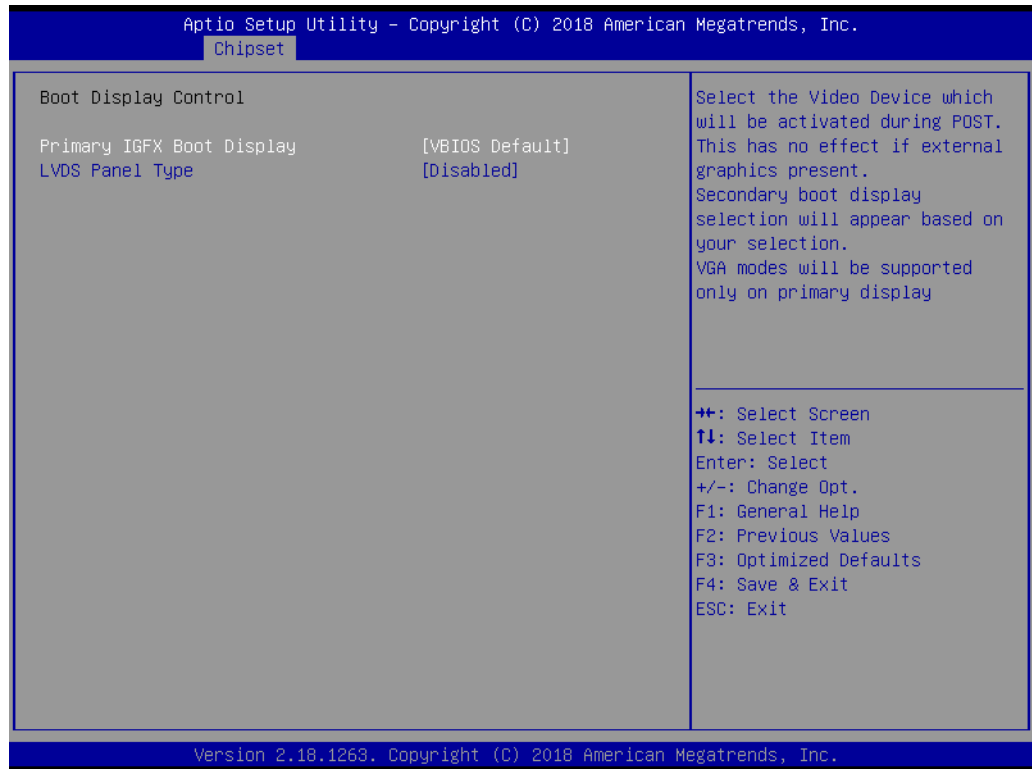

- **Primary IGFX Boot Display**
Select the video device which will be activated during POST. This has no effect if an external graphics card is present. Secondary boot display selection will appear based on your selection. VGA modes will be supported only on the primary display.
- **LVDS Panel Type**
This item allows the user to select LVDS panel type.

3.1.3.5 South Bridge

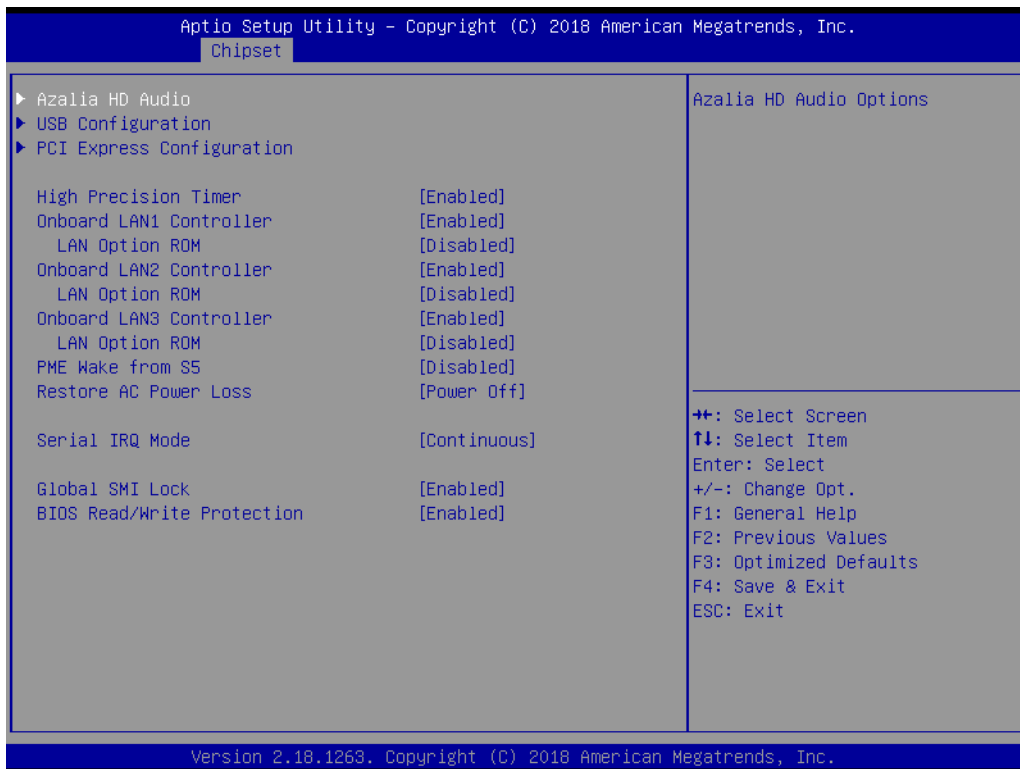

- **Azalia HD Audio**
Azalia HD Audio options.
- **USB Configuration**
USB Configuration Settings.
- **PCI Express Configuration**
PCI Express Configuration settings.
- **High Precision Timer**
Enable or disable the High Precision Event Timer.
- **Onboard LAN1 Controller**
Enable or disable onboard LAN1 Controller.
- **LAN PXE OpROM**
Enable or disable onboard LAN's PXE option ROM.
- **Onboard LAN2 Controller**
Enable or disable onboard LAN2 Controller.
- **LAN PXE OpROM**
Enable or disable onboard LAN's PXE option ROM.
- **Onboard LAN3 Controller**
Enable or disable onboard LAN3 Controller.
- **LAN PXE OpROM**
Enable or disable onboard LAN's PXE option ROM.
- **PCIE Wake from S5**
Enable or disable PCIE to wake the system from S5.
- **Restore AC Power Loss**
Select AC power state when power is re-applied after a power failure.
- **Serial IRQ Mode**
Configure Serial IRQ Mode.

- **Global SMI Lock**
Enable or disable SMI lock.
- **BIOS Read/Write Protection**
Enable or disable BIOS SPI region read/write protect.

3.1.3.6 Azalia HD Audio

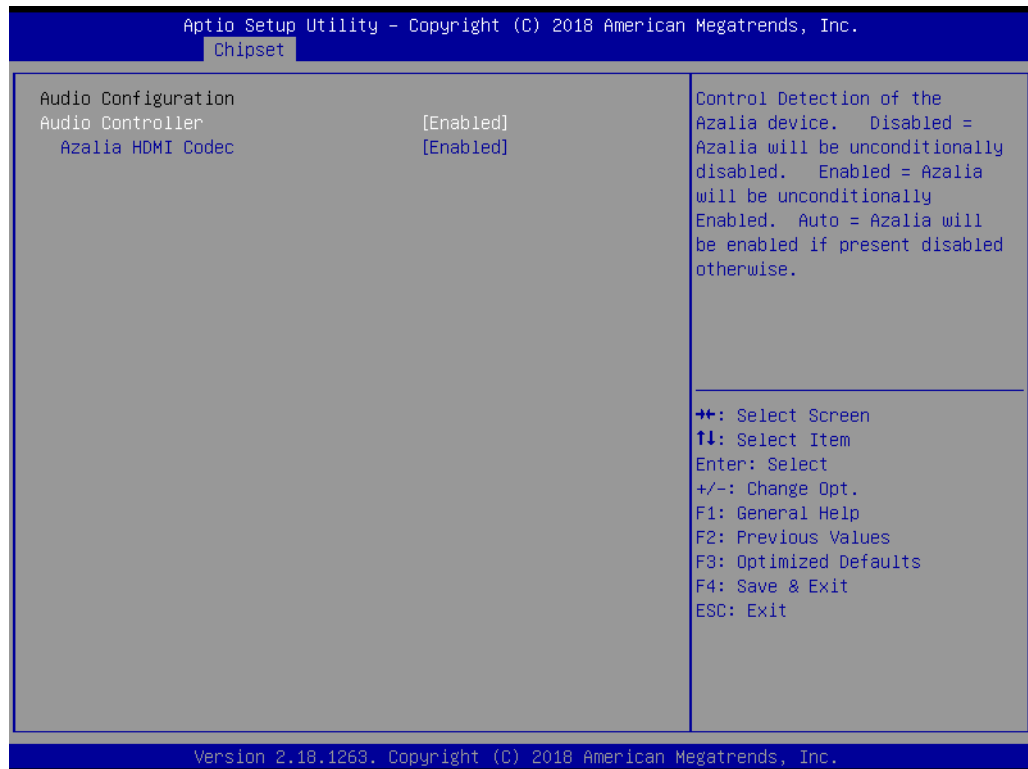

- **Audio Controller**
Control detection of the Azalia device. Disabled = Azalia will be unconditionally disabled. Enabled = Azalia will be unconditionally enabled.
- **Azalia HDMI Codec**
Enable or disable internal HDMI codec for Azalia.

3.1.3.7 USB Configuration

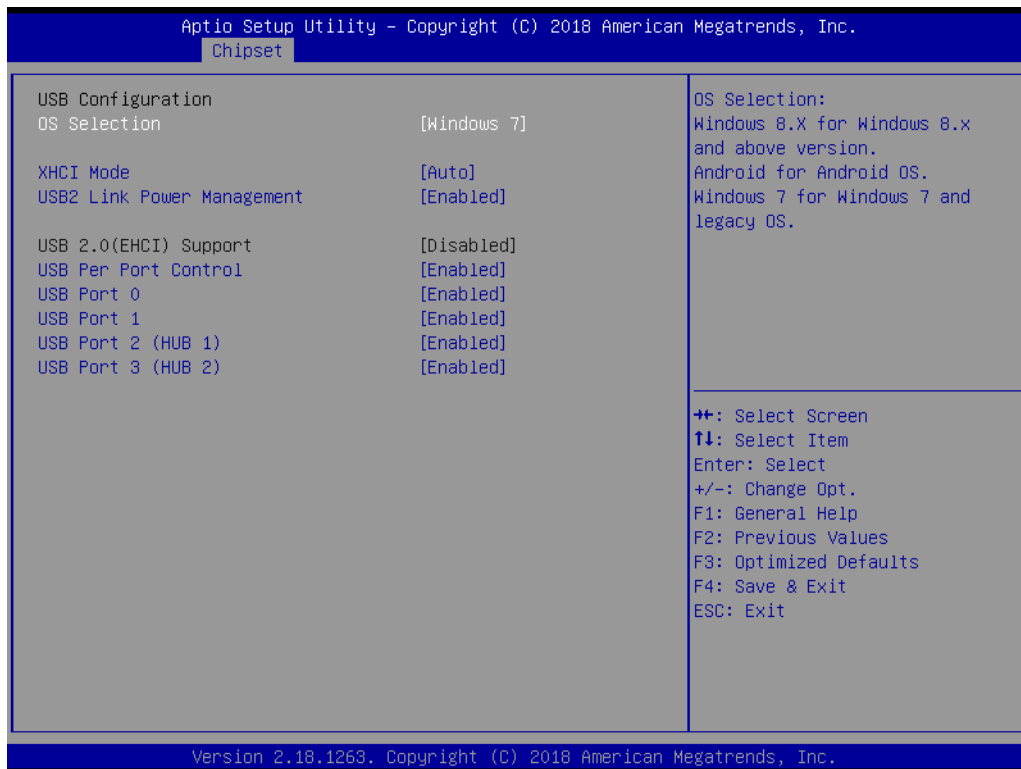

- **OS Selection**
Windows 8.X for Windows 8.x and above version. Android for Android OS. Windows 7 for Windows 7 and legacy OS.
- **XHCI Mode**
Mode of operation of xHCI controller.
- **USB2 Link Power Management**
Enable or disable USB2 Link Power Management.
- **USB 2.0 <https://www.youtube.com/watch?v=QPXvAM9blow>(EHCI) Support**
Control the USB EHCI (USB 2.0) functions. One EHCI controller must always be enabled.
- **USB Per Port Control**
Control each of the USB ports (0~3). Enable: Enable USB per port; Disable: Use USB port X settings.

3.1.3.8 PCI Express Configuration

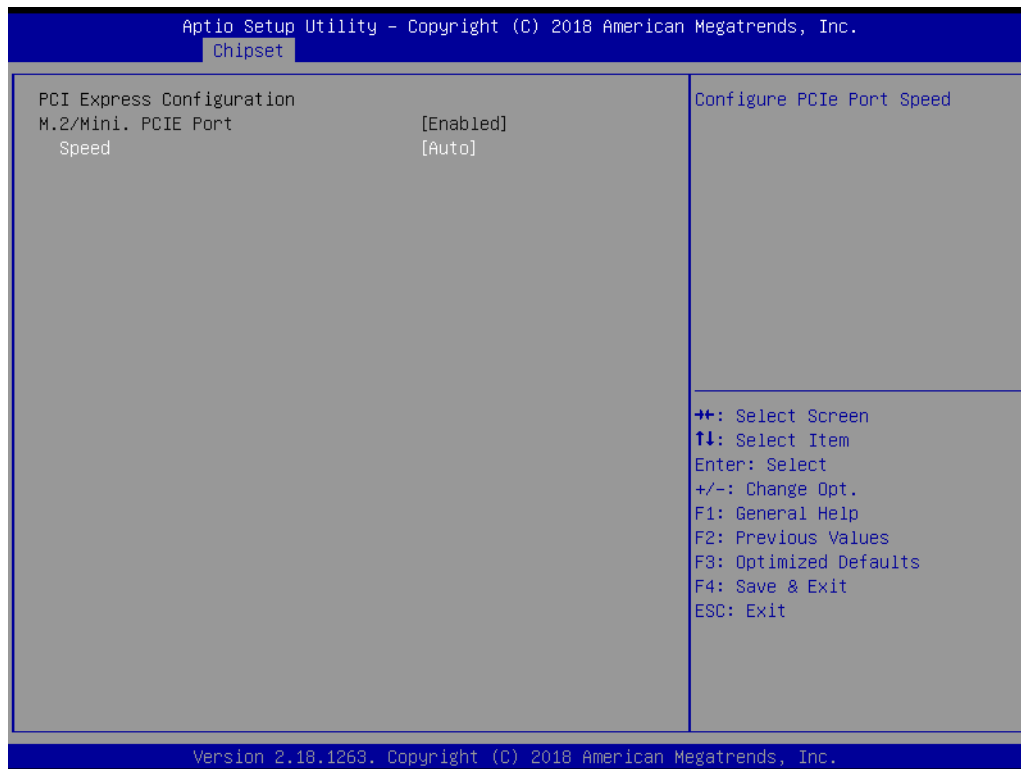

- **M.2/Mini. PCIE Port**
Enable or Disable the M.2/Mini. PCI Express Port in the Chipset.
- **Speed**
Configure PCIe Port Speed.

3.1.4 Security

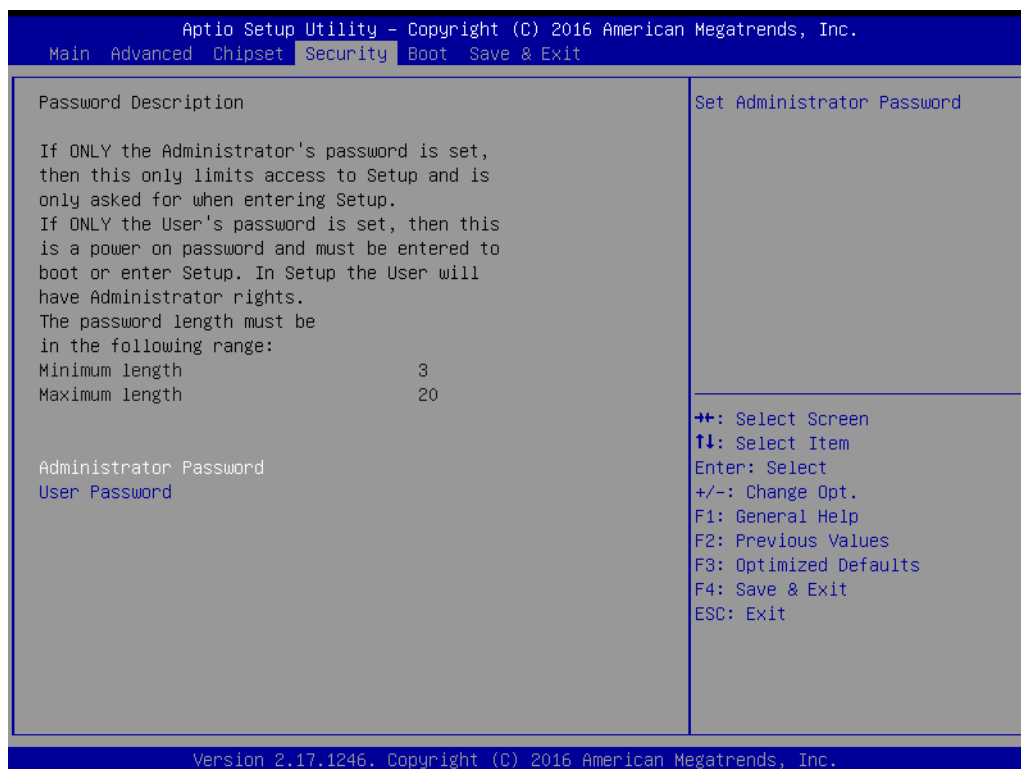

Select Security Setup from the MIO-5850 Setup main BIOS setup menu. All Security Setup options, such as password protection and virus protection are described in this section. To access the sub menu for the following items, select the item and press <Enter>:

- **Change Administrator / User Password**

Select this option and press <ENTER> to access the sub menu, and then type in the password.

3.1.5 Boot

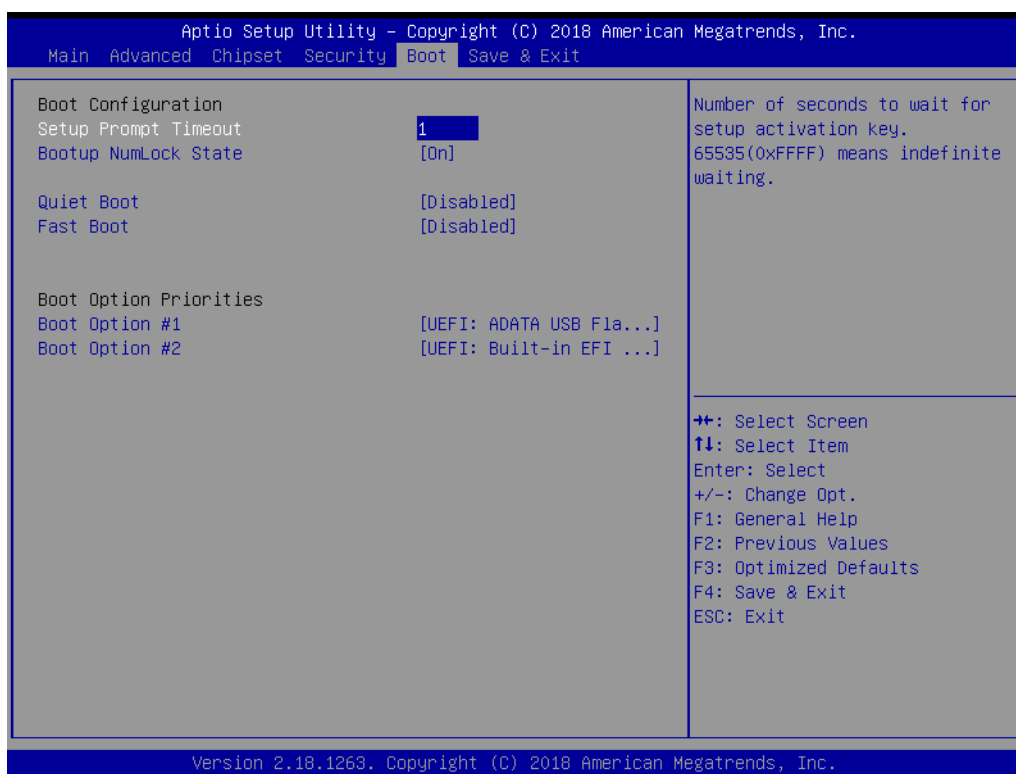

- **Setup Prompt Timeout**

Number of seconds that the firmware will wait before initiating the original default boot selection. A value of 0 indicates that the default boot selection is to be initiated immediately on boot. A value of 65535(0xFFFF) indicates that firmware will wait for user input before booting. This means the default boot selection is not automatically started by the firmware.

- **Bootup NumLock State**

Select the keyboard NumLock state.

- **Quiet Boot**

Enables or disables Quiet Boot option.

- **Boot Option #1**

Sets the system boot order.

- **Fast Boot**

Enables or disables boot with initialization of a minimal set of devices required to launch active boot option. Has no effect for BBS boot options.

- **New Boot Option Policy**

Controls the placement of newly detected UEFI boot options.

3.1.6 Save & Exit

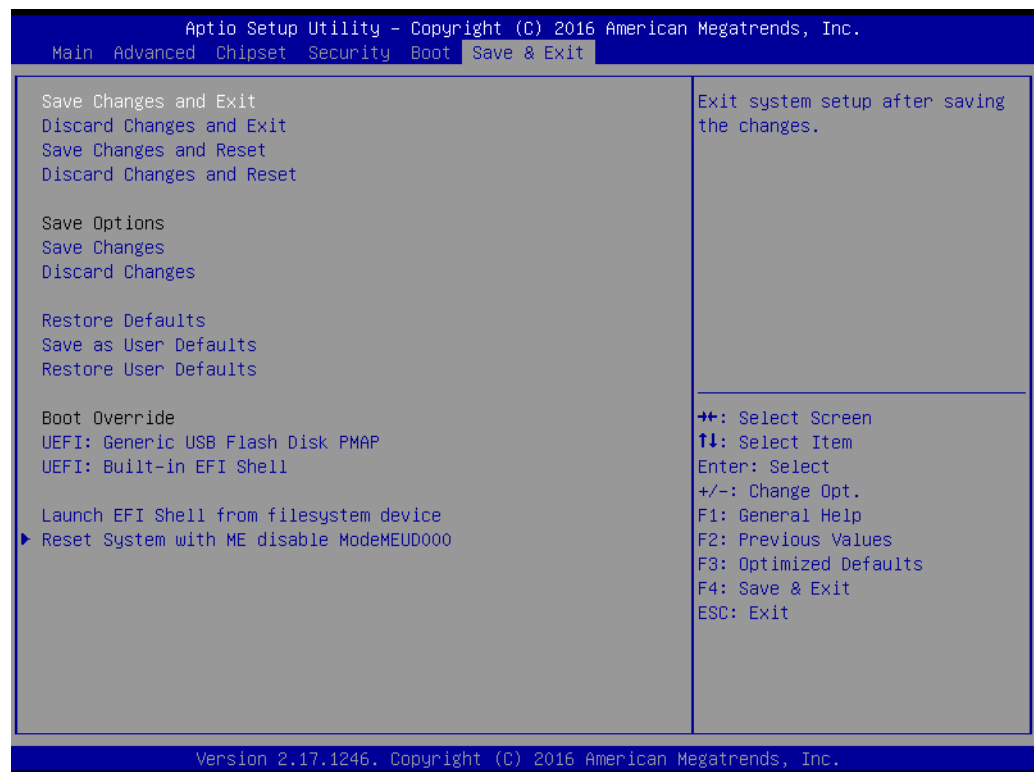

- **Save Changes and Exit**
This item allows you to exit system setup after saving the changes.
- **Discard Changes and Exit**
This item allows you to exit system setup without saving any changes.
- **Save Changes and Reset**
This item allows you to reset the system after saving the changes.
- **Discard Changes and Reset**
This item allows you to rest system setup without saving any changes.
- **Save Changes**
This item allows you to save changes done so far to any of the options.
- **Discard Changes**
This item allows you to discard changes done so far to any of the options.
- **Restore Defaults**
This item allows you to restore/load default values for all the options.
- **Save as User Defaults**
This item allows you to save the changes done so far as user defaults.
- **Restore User Defaults**
This item allows you to restore the user defaults to all the options.
- **Boot Override**
Boot device select can override your boot priority.

Chapter 4

Installation

The MI/O compact form factor SBC is a new-generation SBC design with a variety of mechanical improvements. Here is the quick installation guide for our thermal design and MIOe module installation.

4.1 Quick Installation Guide:

- 1. There is a Heatsink / Cooler in the white box inside the package. Carefully remove the release paper from the thermal pad before installation.

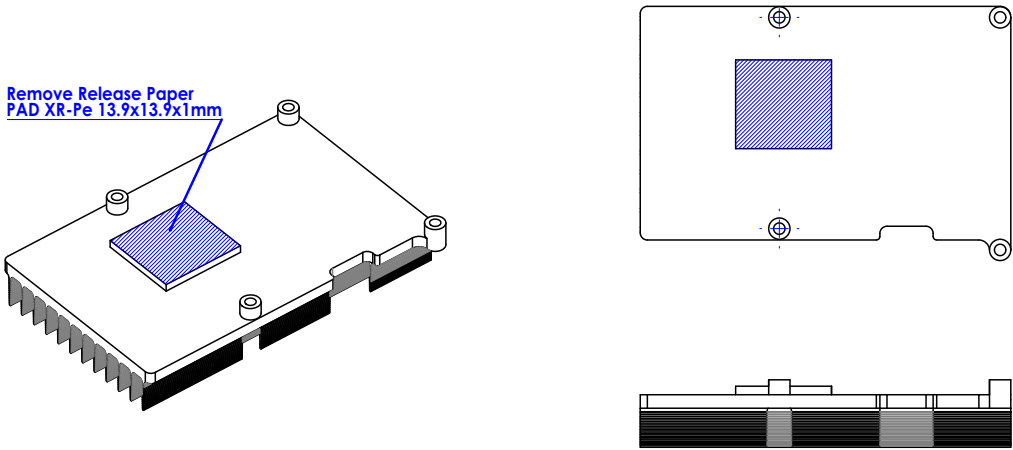

- 2. There are six screws and six studs inside the white box, please install the heat-sink into place as per illustration below:

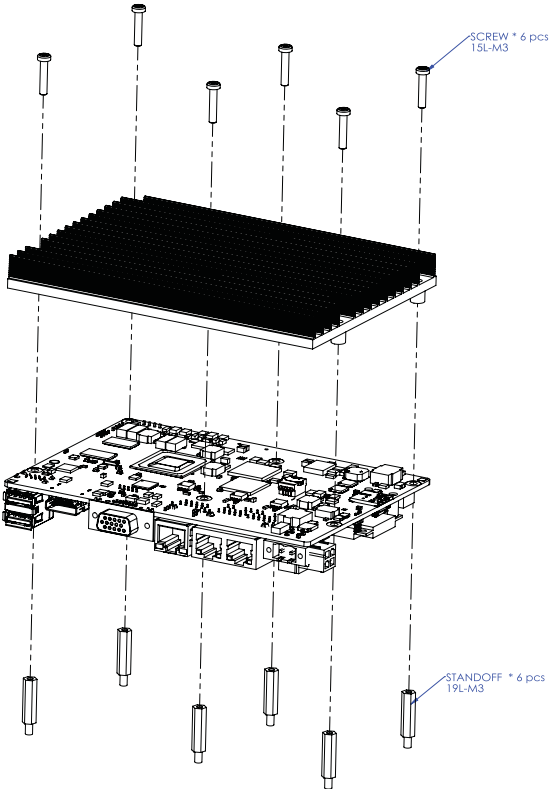

Appendix **A**

Pin Assignments

This appendix contains information of a detailed or specialized nature.

Sections include:

- Jumper and Connector Tables

A.1 Jumper List

J1	Clear CMOS
Part Number	1653003101
Footprint	HD_3x1P_79_D
Description	PIN HEADER 3x1P 2.0mm 180D(M) DIP 2000-13 WS
Setting	Function
(1-2)*	Normal
(2-3)	Clear COMS



J2	Auto Power On Setting
Part Number	1653002101-02
Footprint	HD_2x1P_79_D
Description	PIN HEADER 2x1P 2.0mm 180D(M) DIP 21N12050
Setting	Function
NC	Power Button for Power On
(1-2)*	Auto Power On



J4	LCD power
Part Number	1653003260
Footprint	HD_3x2P_79
Description	PIN HEADER 3x2P 2.0mm 180D(M) SMD 21N22050
Setting	Function
(1-3)*	+3.3V
(3-5)	+5V
(3-4)	+12V



J5	LVDS VCON Setting
Part Number	1653000014
Footprint	HD_2x2P_79
Description	PIN HEADER 2x2P 2.00mm 180D(M) SMD 21N22050
Setting	Function
(1-2)*	3.3V High for VCON on LVDS
(1-3)	Low for VCON on LVDS



A.2 Connector Pin Definition

CN1	M.2 E key
Part Number	00A00001500
Footprint	CARRIER_TYPE-2230-D3-E
Description	
Pin	Pin Name

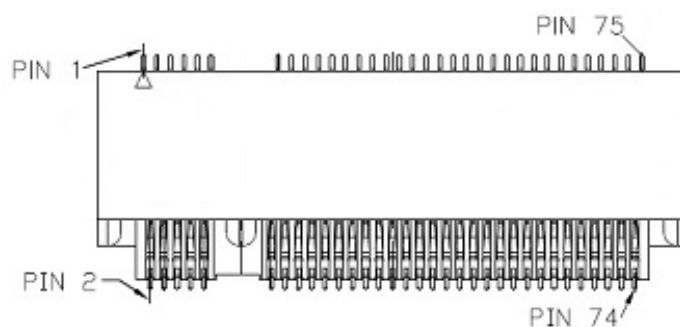

CN2	RTC Battery
Part Number	1655005427-01
Footprint	WF_2P_49_53398-0271
Description	
Pin	Pin Name
1	GND
2	+VBAT



CN3	CAN BUS
Part Number	1654903500
Footprint	WHL3VS-125M
Description	CONN. Molex 53398-0390 3P 1.25Pitch 90D(M) SMD 7
Pin	Pin Name
1	CAN1_D+
2	CAN1_D-
3	CAN_GND



CN4	SATA Power
Part Number	1655001154
Footprint	WF_4P_98_BOX_R1_D
Description	WAFER BOX 4P 2.50mm 180D(M) DIP 24W1170-04S10-01
Pin	Pin Name
1	+5V
2	GND
3	GND
4	+12V

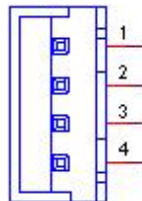

CN6	Front Panel
Part Number	1655003684
Footprint	WF_4x2P_79_BOX_RD1_D
Description	
Pin	Pin Name
1	Reset
2	Power Switch
3	GND
4	GND
5	Case Open
6	Power LED
7	HD LED-
8	HD LED+

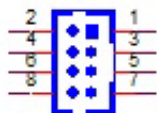

CN7	SATA_7V
Part Number	1654011616-01
Footprint	SATA_7P_WATF-07DBN6SB1U
Description	Serial ATA 7P 1.27mm 180D(M) SMD WATF-07DBLSB1UW
Pin	Pin Name

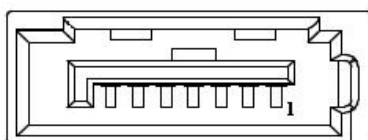

CN8	Internal USB
Part Number	1653004515
Footprint	HD5x2P_79_23N685B-10M10_N10
Description	BOX HEADER 5x2P 2.0mm 180D(M) SMD 23N685B-10M10
Pin	Pin Name
1	+5V
2	+5V
3	A_D-
4	B_D-
5	A_D+
6	B_D+
7	GND
8	GND
9	GND

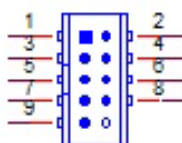

CN9	Internal USB
Part Number	1653004515
Footprint	HD5x2P_79_23N685B-10M10_N10
Description	BOX HEADER 5x2P 2.0mm 180D(M) SMD 23N685B-10M10
Pin	Pin Name
1	+5V
2	+5V
3	A_D-
4	B_D-

5	A_D+
6	B_D+
7	GND
8	GND
9	GND

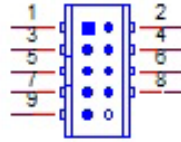

CN10	COM1/COM2/RS422/RS485/RS232
Part Number	1653004793
Footprint	HD_10x2P_79_23N685B-20M10
Description	BOX HEADER 10x2P 2.0mm 180D(M)SMD 23N685B-20M10B
Pin	Pin Name
1	422TX1-/485D1-/DCD1#
2	DSR1#
1	422TX1+/485D1+/RXD1
4	RTS1#
5	422RX1+/TXD1
6	CTS1#
7	422RX1-/DTR1#
8	RI1#
9	GND
10	GND
11	422TX2-/485D2-/DCD2#
12	DSR2#
11	422TX2+/485D2+/RXD2
14	RTS2#
15	422RX2+/TXD2
16	CTS2#
17	422RX2-/DTR2#
18	RI2#
19	GND
20	GND

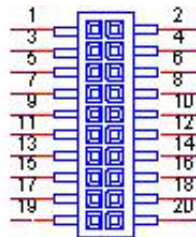

CN11	COM3/COM4
Part Number	1653004793
Footprint	HD_10x2P_79_23N685B-20M10
Description	BOX HEADER 10x2P 2.0mm 180D(M)SMD 23N685B-20M10B
Pin	Pin Name
1	DCD3#
2	DSR3#
3	RXD3
4	RTS3#
5	TXD3
6	CTS3#
7	DTR3#
8	RI3#
9	GND
30	GND
11	DCD4#
14	DSR4#
13	RXD4
14	RTS4#
15	TXD4
16	CTS4#
17	DTR4#
18	RI4#
19	GND
20	GND

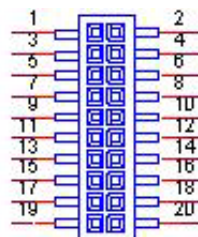

CN12	I2C
Part Number	1655904020
Footprint	FPC4V-125M
Description	WAFER 4P 1.25mm 180D(M) SMD 85205-04001
Pin	Pin Name
1	GND
2	I2C_DAT
3	I2C_CLK
4	+V5_I2C

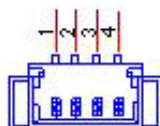

CN13	SM BUS
Part Number	1655004032
Footprint	WF_5P_49_BOX_85205
Description	WAFER 5P 1.25mm 180D(M) SMD 85205-05701
Pin	Pin Name
1	GND
2	SMB_ALERT#
3	SMB0_DAT
4	SMB0_CLK
5	+V5_SMB

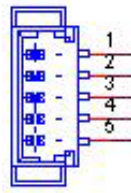

CN14	FAN
Part Number	1655004347
Footprint	WF_4P_100_D_744-81-04TW30
Description	WAFER 2.54 1*4P 180D(M) DIP 744-81-04TW30
Pin	Pin Name
1	GND
2	+V12_FAN
3	FAN_SPEED
4	FAN_PWM

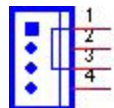

CN16	Audio
Part Number	1653004099
Footprint	HD_5x2P_79_23N685B-10M10
Description	BOX HEADER 5x2P 2.00mm 180D(M) SMD 23N685B-10M10
Pin	Pin Name
1	LOUTR
2	LINR
3	GND
4	GND
5	LOUTL
6	LINL
7	GND
8	GND
9	MIC1R
10	MIC1L

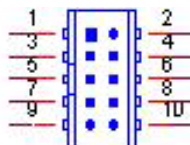

CN17	GPIO_P0
Part Number	1653004099
Footprint	HD_5x2P_79_23N685B-10M10
Description	BOX HEADER 5x2P 2.00mm 180D(M) SMD 23N685B-10M10
Pin	Pin Name
1	+5V
2	P0_GPIO4
3	P0_GPIO0
4	P0_GPIO5
5	P0_GPIO1
6	P0_GPIO6
7	P0_GPIO2
8	P0_GPIO7
9	P0_GPIO3
10	GND

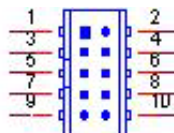

CN18	GPIO_P1
Part Number	1653004099
Footprint	HD_5x2P_79_23N685B-10M10
Description	BOX HEADER 5x2P 2.00mm 180D(M) SMD 23N685B-10M10
Pin	Pin Name
1	+5V
2	P1_GPIO4
3	P1_GPIO0
4	P1_GPIO5
5	P1_GPIO1
6	P1_GPIO6
7	P1_GPIO2
8	P1_GPIO7
9	P1_GPIO3
10	GND

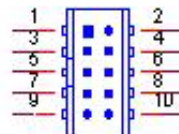

CN19	mSATA
Part Number	1654009402
Footprint	MINIPCI_52P_AS0B226-S40N-7F
Description	MINI PCI 52P 0.8mm 90D(F) SMD AS0B226-S40Q-7H
Pin	Pin Name

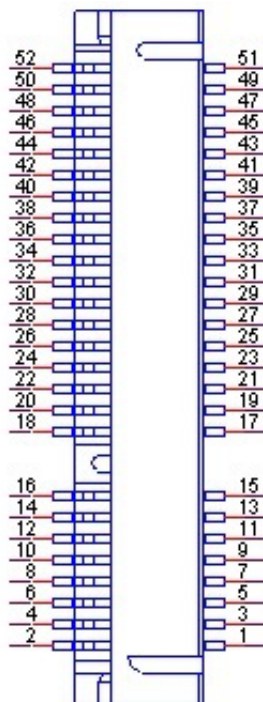

CN20	MINIPCI Express
Part Number	1654011230-01
Footprint	MINIPCI_52P_88908-5204M
Description	MINIPCIExpress 52P 0.8mm RVS H=9.9mm 90D(F) SMD
Pin	Pin Name

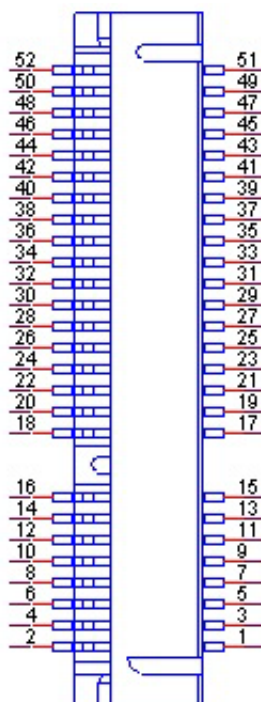

CN22	Inverter Power Output
Part Number	1655305020
Footprint	WHL5V-2M
Description	WAFER BOX 5P 2.0mm 180D(M) DIP A2001WV2-5P
Pin	Pin Name
1	+12V
2	GND
3	ENABKL
4	VBR
5	+5V

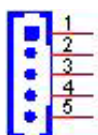

CN23	RJ45_2x1_W/XFMR&LED
Part Number	1652003274
Footprint	RJ45_28P_RTB-19GB9J1A
Description	PHONE JACK RJ45 28P DIP RTB-19GB9J1A
Pin	Pin Name

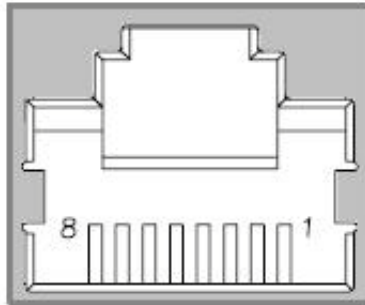

CN24	RJ45_W/XFMR&LED
Part Number	1652004356
Footprint	RJ45_14P_RT7-194AAM1A
Description	PHONE JACK RJ45 14P 90D(F) DIP RT7-194AAM1A
Pin	Pin Name

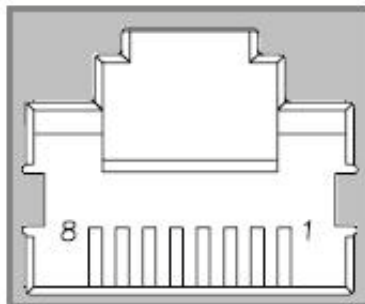

CN25	48-bit LVDS Panel
Part Number	1653920200
Footprint	SPH20X2
Description	B/B Conn. 40P 1.25mm 90D SMD DF13-40DP-1.25V(91)
Pin	Pin Name
1	+12V or +5V or +3.3V
2	+12V or +5V or +3.3V
3	GND
4	GND
5	+12V or +5V or +3.3V
6	+12V or +5V or +3.3V
7	LVDS0_D0-
8	LVDS1_D0-
9	LVDS0_D0+
10	LVDS1_D0+
11	GND
12	GND
13	LVDS0_D1-
14	LVDS1_D1-
15	LVDS0_D1+
16	LVDS1_D1+
17	GND
18	GND
19	LVDS0_D2-
20	LVDS1_D2-
21	LVDS0_D2+
22	LVDS1_D2+
23	GND
24	GND
25	LVDS0_CLK-
26	LVDS1_CLK-
27	LVDS0_CLK+
28	LVDS1_CLK+
29	GND
30	GND
31	NC
32	NC
33	GND
34	GND
35	LVDS0_D3-
36	LVDS1_D3-
37	LVDS0_D3+
38	LVDS1_D3+
39	NC
40	VCON

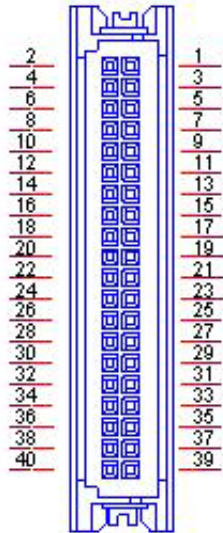

CN26	USB2.0+3.0_13H
Part Number	1654010199
Footprint	USB_13P_UEA1112C-UHS6-4F
Description	USB Conn. 2.0+3.0 13P 90D(F) DIP UEA1112C-UHS6-4
Pin	Pin Name

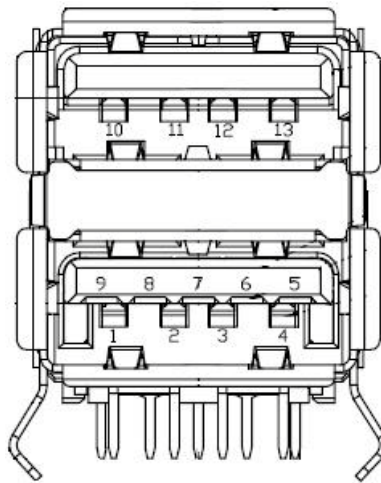

CN28	HDMI_19H
Part Number	1654011175-01
Footprint	HDMI_19P_QJ51191-LFB4-7F
Description	HDMI Conn. 19P 0.5mm 90D(F) SMD QJ51191-LFB4-7F
Pin	Pin Name

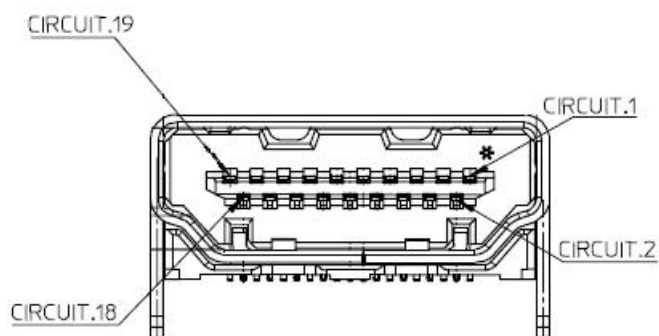

CN29	Power input
Part Number	1652000089
Footprint	ME050-50002
Description	PLUG-IN BLOCK 2P 5.00mm 90D(M) DIP ME050-5002
Pin	Pin Name
1	GND
2	+12V or +24V

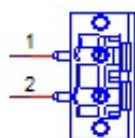

CN31	VGA
Part Number	1654011261-01
Footprint	DBVGA-VF5MS
Description	D-sub 15P 90D(F) DIP G/F HDB5-15F1-KNR0-G7
Pin	Pin Name
1	RED
2	GREEN
3	BLUE
4	NC
5	GND
6	GND
7	GND
8	GND
9	+5V
10	GND
11	NC
12	DDAT
13	HSYNC
14	VSYNC
15	DCLK

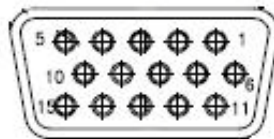

CN32	NANO SIM
Part Number	1654013206-01
Footprint	SIM_6P_N080613-SICR10
Description	Nano SIM Card 6P/1.27/(F)/LCP/RA/GFL/S/BK/H1.37
Pin	Pin Name

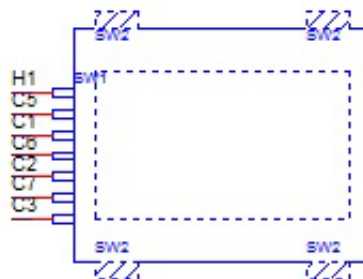

Appendix **B**

How to install Win7 64-bit

B.1 Purpose

Instructions for Win7 64bit installation on MIO-5850 eMMC.

B.2 Requirement:

Intel eMMC/SD card driver(iaiosd folder)

Win7 64bit SP1 installation disc.

Storport.sys file

B.3 Instruction

Inject storport.sys into Windows & 64 bit SP1 installer.

1. In C drive, make a folder "image" and go into "image" folder make another folder name "mount".
2. Open Windows 7 64bit SP1 ISO file, extract files: boot.wim & install.wim to directory: C:\image.
3. Launched Command Prompt with administrator privileges.
4. Mount boot.wim 1 image with write permissions.
C:\windows\system32>dism /mount-Wim /WimFile:C:\image\boot.wim /Index:1 /MountDir:C:\image\mount
5. Open a Windows Explorer window and navigate to C:\image\mount\Windows\System32\drivers.
6. Locate and replace the existing storport.sys file
7. Unmount and commit the boot.wim 1 image.
C:\windows\system32>dism /Unmount-Wim /MountDir:C:\image\mount /Commit
8. Again, Mount boot.wim 2 image with write permissions.
C:\windows\system32>dism /mount-Wim /WimFile:C:\image\boot.wim /Index:2 /MountDir:C:\image\mount
9. Open a Windows Explorer window and navigate to C:\image\mount\Windows\System32\drivers.
10. Locate and replace the existing storport.sys file
11. Unmount and commit the boot.wim 2 image.
C:\windows\system32>dism /Unmount-Wim /MountDir:C:\image\mount /Commit
12. For install.wim, mount the WIM image with write permissions:
C:\windows\system32>dism /mount-Wim /WimFile:C:\image\install.wim /Index:4 /MountDir:c:\image\mount
Index 4, is in the case for Windows 7 Ultimate Edition 64-Bit. In case you need other editions of Windows 7, run following command:
C:\Windows\System32>dism /Get-WimInfo /WimFile:E:\wim\install.wim
And select correspondent index number.
13. Open a Windows Explorer window and navigate to C:\image\mount\Windows\System32\drivers. Locate and replace the existing storport.sys file. If you cannot replace the storport.sys file due to access permission, please follow instructions to change access permission for a file.

14. Locate the “storport.sys” file and click the file, right click, properties.

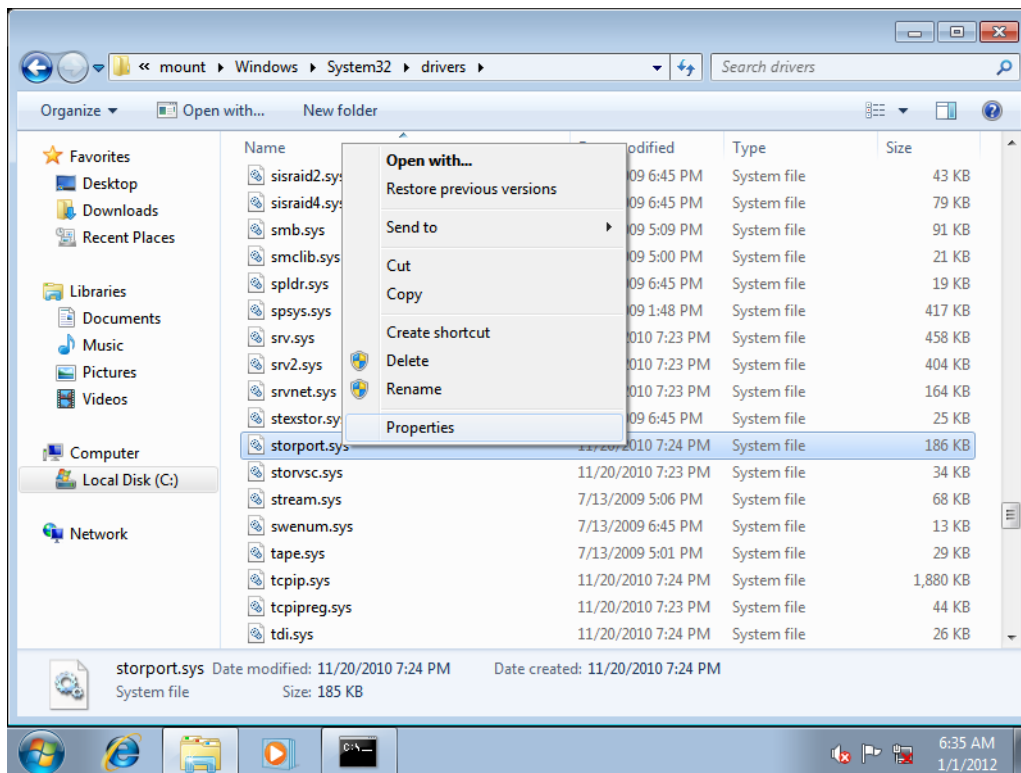

15. Click “Security” tab and click on “Advanced”

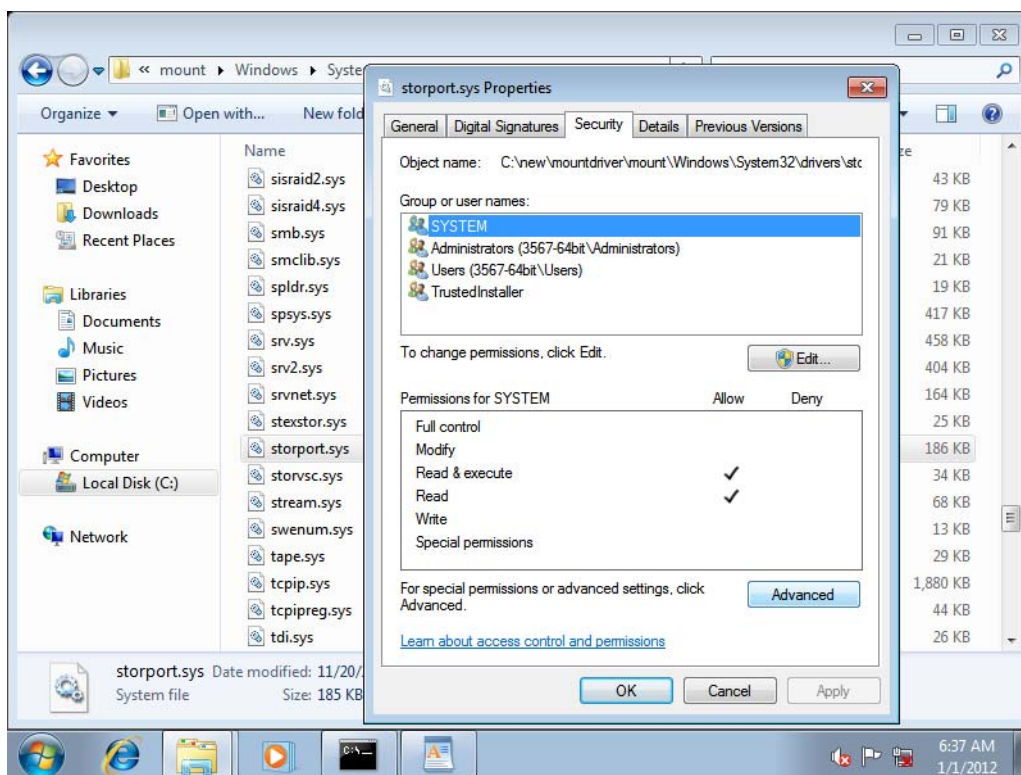

16. Click on "Owner" tab and click on "Edit"

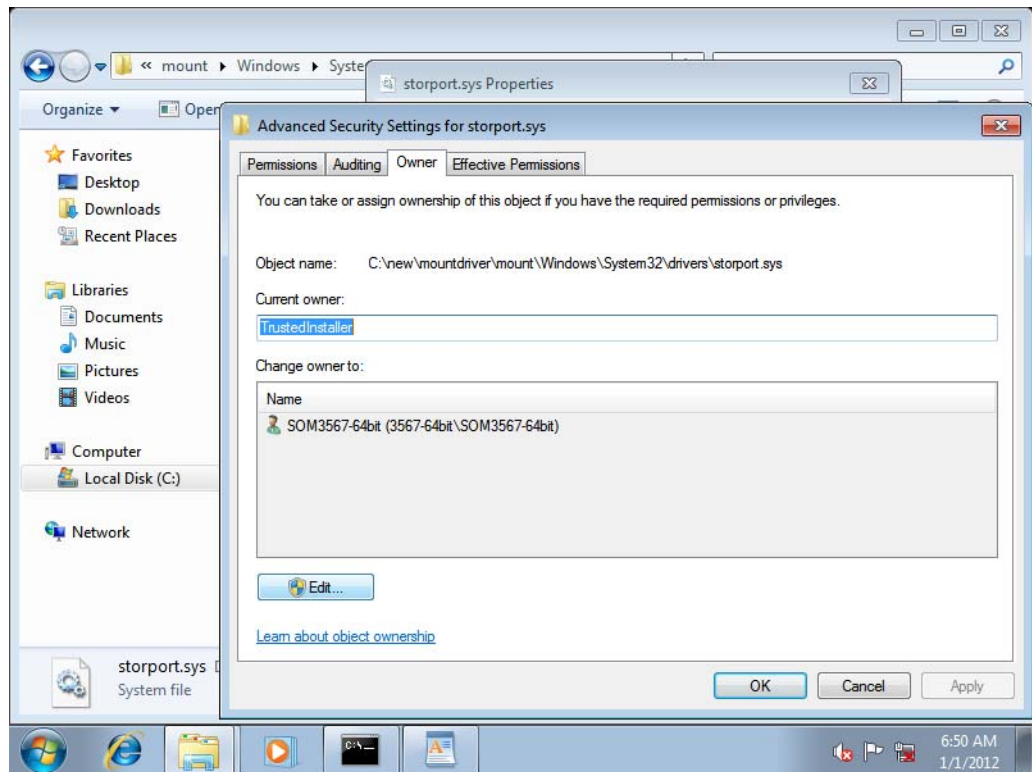

17. Select currently login name on the pop up window and click "Ok"

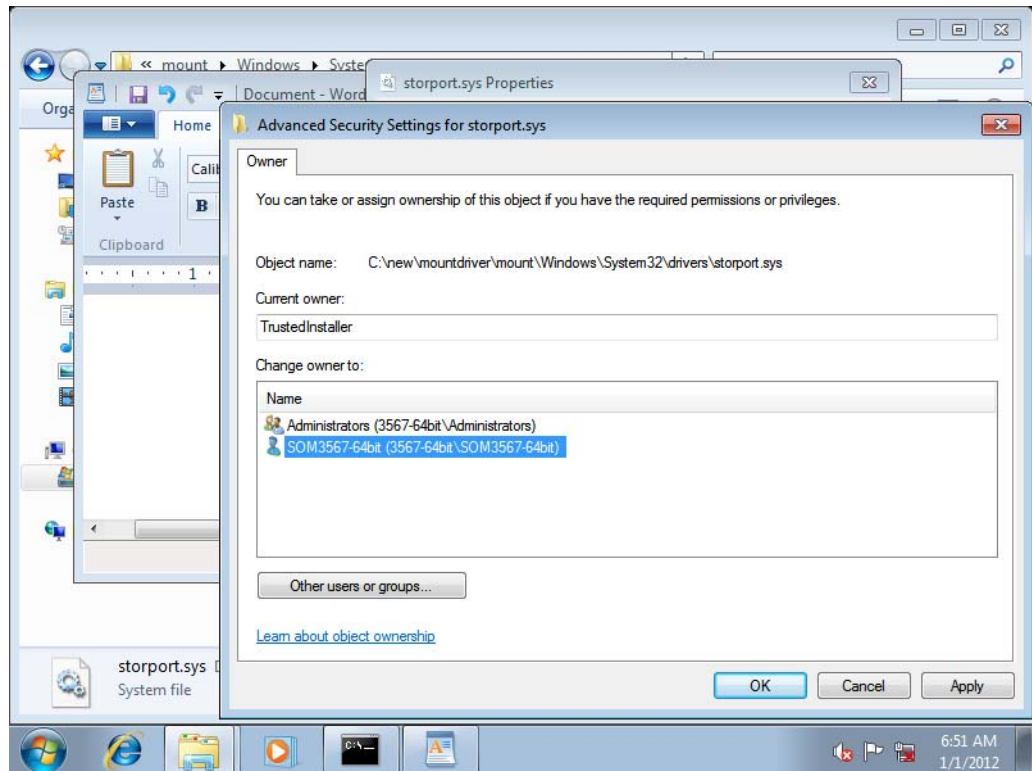

18. Click on “OK” on the pop up window.

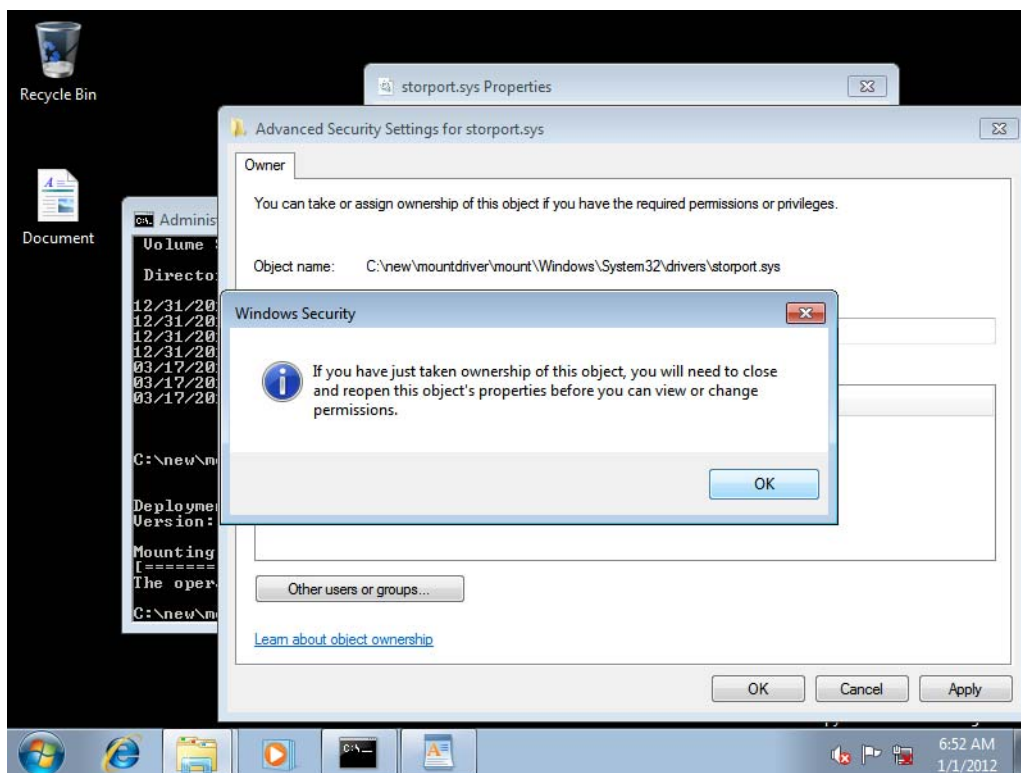

19. Click “ok” to close all pup up windows.
20. Locate the “storport.sys” file and click the file, right click, “Properties” again.

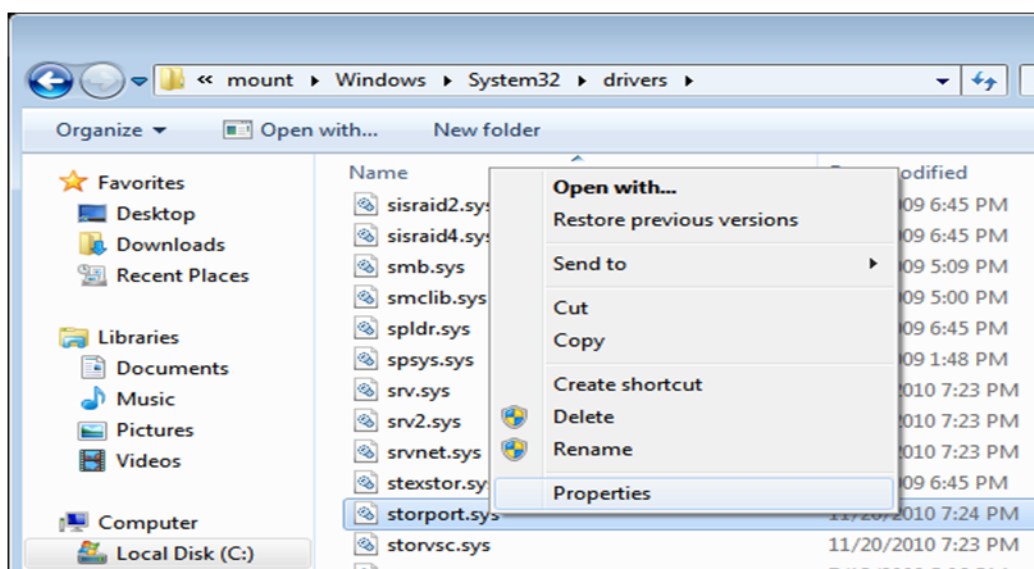

21. Click on “Security” Tab and click on “Edit”.

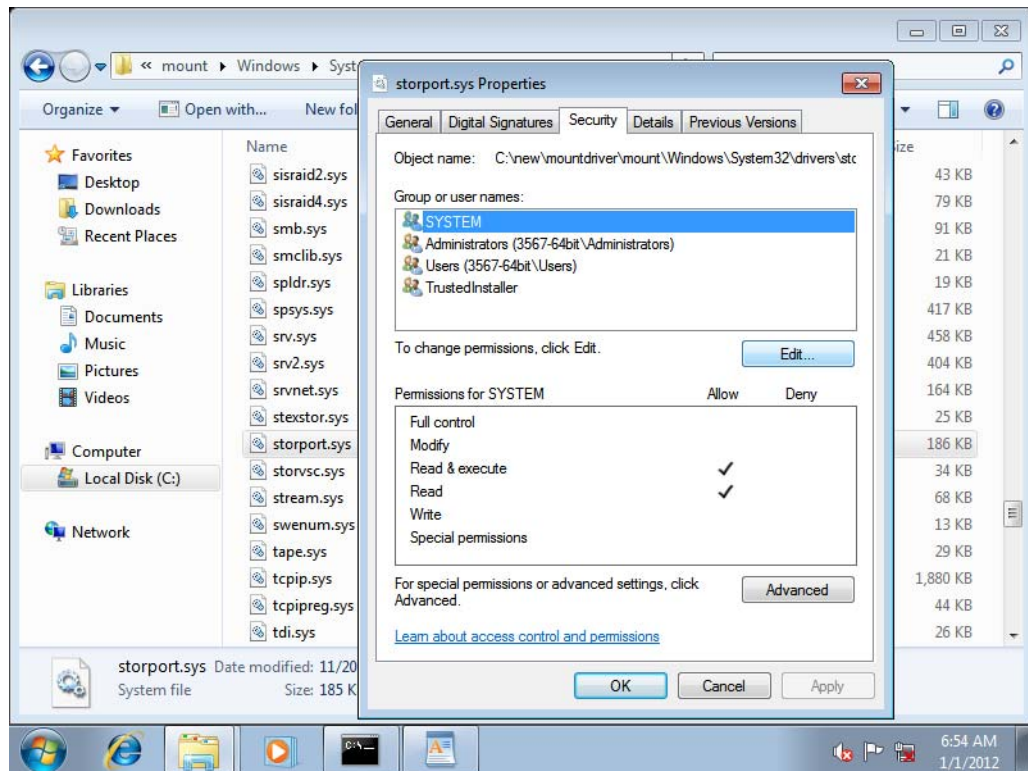

22. Select currently login name and change access permission to full control. Then, click on “Ok”.
23. Click “Ok” on popup windows. Then, you can replace “storport.sys” file.
24. Unmount and commit the install.wim image.
`C:\windows\system32>dism /Unmount-Wim /MountDir:E:\temp /Commit`
25. Done for injecting storport.sys into Windows 7 64Bit SP1 installer.
26. Replace the boot.wim and install.wim in the USB pendrive with Windows 7 64Bit installer in folder: <USB pendrive>:\sources\. The installer is ready to use.
27. Copy the Intel eMMC/SD card driver(iaiosd folder) to the installer pendrive.
28. Go to BIOS setup menu, and go to “Advance\Miscellaneous configuration\OS selection” and set to “Windows 7”

29. Save the setting and install Win7 normally until you reach the screen shown below.

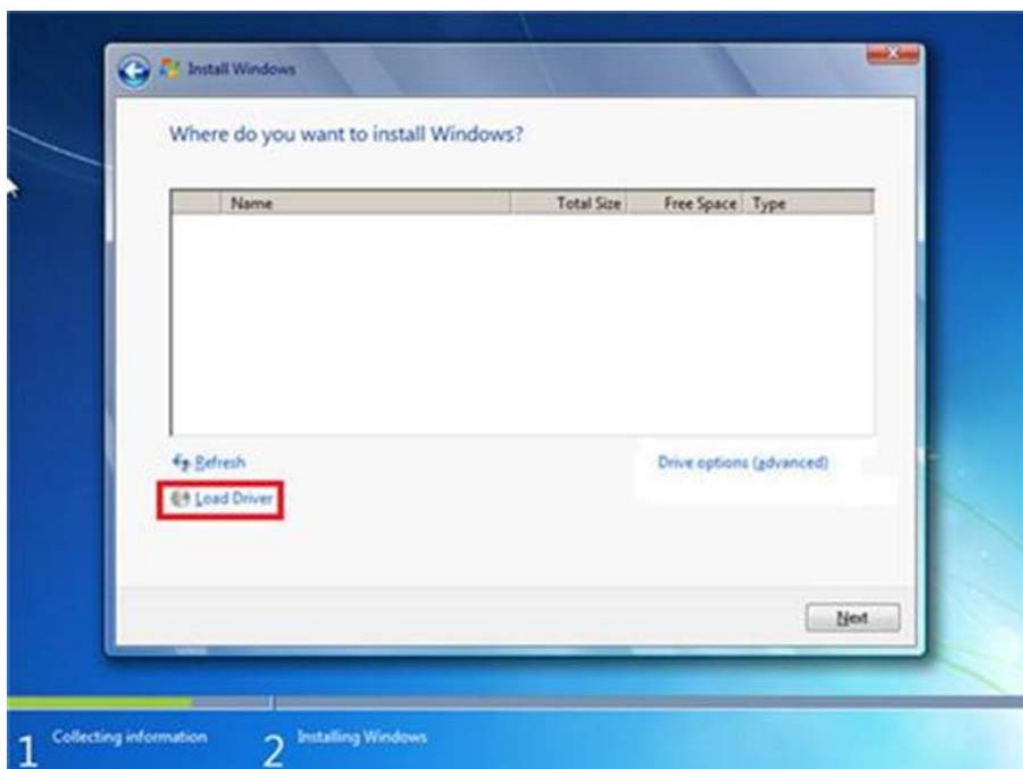

30. Select "load Driver" and Browse to the folder where you have copied eMMC/SD card driver file.

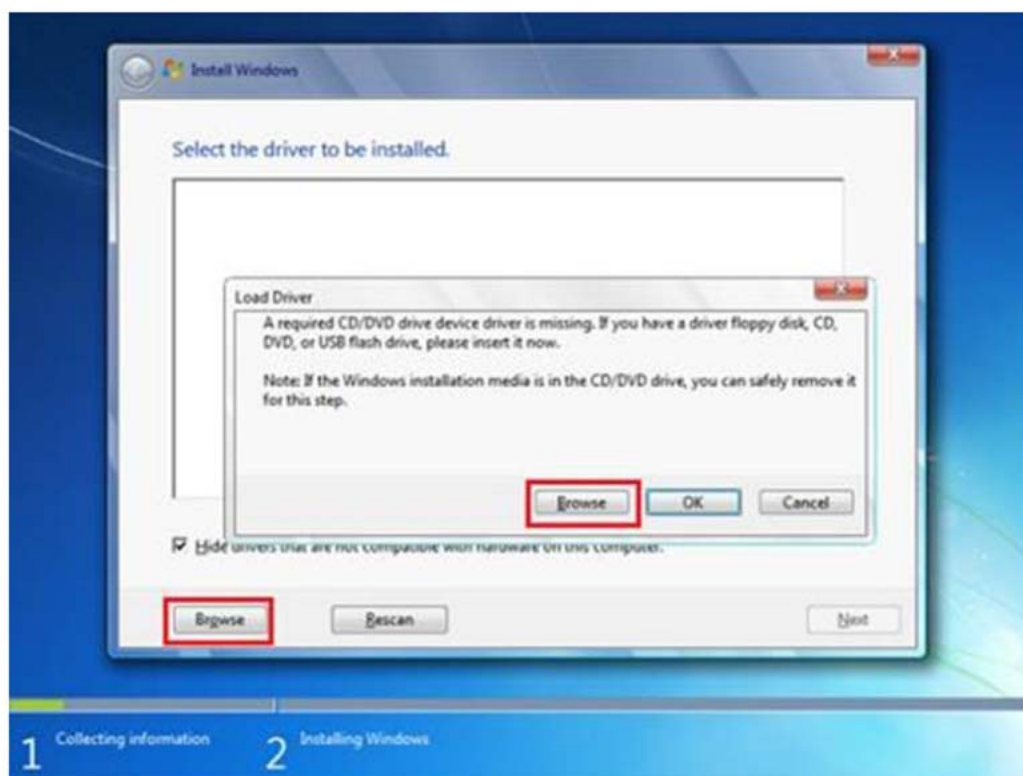

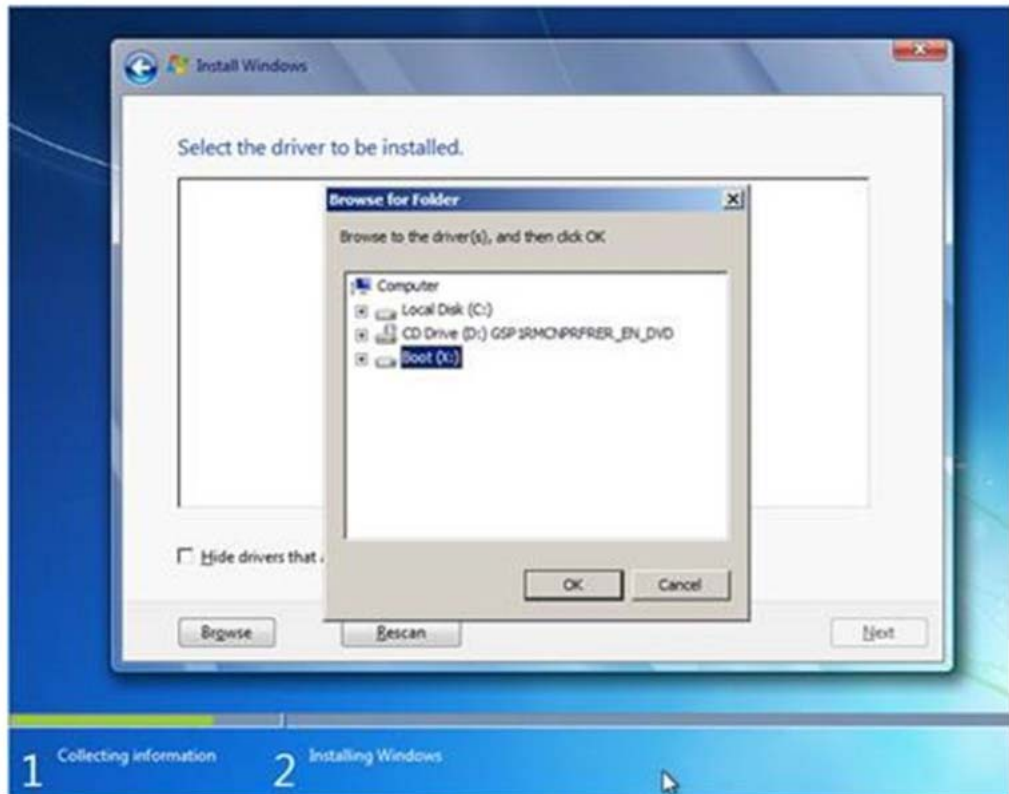

31. Select eMMC host controller driver and press/Click next.

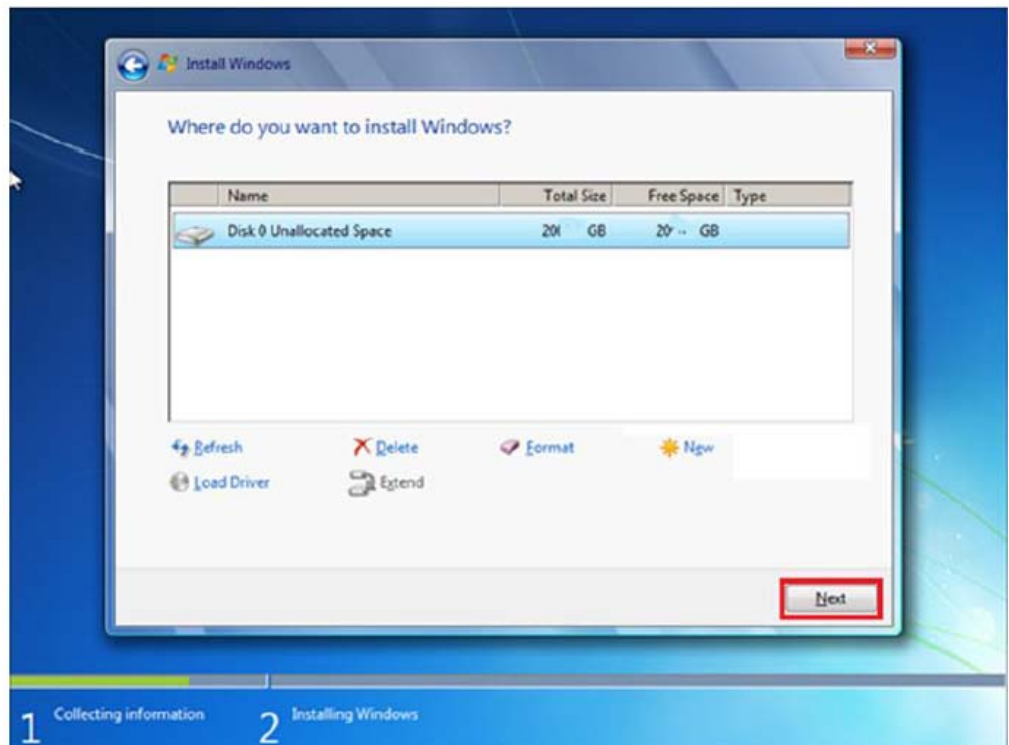

32. Install win7 normally until finish.

Appendix **C**

System Assignments

This appendix contains information of a detailed nature.

Sections include:

- System I/O Ports
- 1st MB Memory Map
- Interrupt Assignments

C.1 System I/O Ports

Table C.1: System I/O Ports

Addr. Range (Hex)	Device
62h/66h	PMC for ACPI EC
200h ~ 27Fh	CAN bus
280h ~ 288h	I2C bus
290h ~ 29Fh	EC resource
2A0h ~ 2B4h	SMBus
2C0h ~ 2C1h	GPIO data
2C4h ~ 2C5h	GPIO direction
2F2h/2F6h	PMC for Susi

C.2 1st MB Memory Map

Table C.2: 1st MB Memory Map

Addr. Range (Hex)	Device
A0000h - BFFFFh	Intel® HD Graphics
A0000h - BFFFFh	PCI Bus
C0000h - DFFFFh	PCI Bus
E0000h - FFFFFh	PCI Bus
90400000 – 905FFFFFF	Intel® Trusted Execution Engine Interface
E0000000 - FFFFFFFF	System resources

C.3 Interrupt Assignments

Table C.3: Interrupt assignments

Interrupt#	Interrupt source
NMI	Parity error detected
IRQ0	System timer
IRQ1	Using SERIRQ, Keyboard Emulation
IRQ2	Slave controller INTR output
IRQ3	Communications Port (COM2)
IRQ4	Communications Port (COM1)
IRQ5	Communications Port (COM4) / iManager WatchDog IRQ
IRQ6	Available
IRQ7	Communications Port (COM3)
IRQ8	Internal RTC or HPET
IRQ9	Microsoft ACPI-Compliant System
IRQ10	Available
IRQ11	Available
IRQ12	Available
IRQ13	Numeric data processor
IRQ14	SATA controller
IRQ15	SATA controller

Appendix **D**

EC Watchdog Timer
Sample Code

D.1 EC Watchdog Timer sample code

Display source code fixed width font for easy reading.

The sample code can be compiled by Open Watcom C++ compiler running on DOS.

```
#include <stdio.h>
#include <string.h>
#include <conio.h>
#include <stdint.h>
#include <i86.h>

#define CMD_PORT      (0x2F6)
#define STS_PORT      CMD_PORT
#define DAT_PORT      (0x2F2)

#define EC_RETRIES    (65535)

#define EC_STS_IBF     0x02
#define EC_STS_OBF     0x01

#define EC_CMD_MASK    0x01 // 1=read command, 0=write command
#define EC_CMD_READ    EC_CMD_MASK

#define WDT_CMD_WRITE  0x2A
#define WDT_CMD_READ   0x2B

#define WDT_CTL        0x02
#define WDT_CTL_CLEAR  0x02
#define WDT_CTL_START  0x01
#define WDT_CTL_STOP   0x00

#define WDT_TYPE_DELAY 0x11 // add delay time before watchdog starting
#define WDT_TYPE_PWRCYC 0x12 // power cycle
#define WDT_TYPE_IRQ    0x13 // issue IRQ
#define WDT_TYPE_RESET  0x14 // reset
#define WDT_TYPE_PIN    0x15 // set watchdog pin
#define WDT_TYPE_SCI    0x16 // issue SCI in ACPI OS

#define inb(p)         inp(p)
#define outb(p, v)     outp(p, v)

//
//=====
//=====
// ec_wait_ibe
//
//=====
//=====
```

```

uint8_t ec_wait_ibe(void)
{
    uint16_t  retries = EC_RETRIES;

    // wait for the input buffer empty
    while (inb(STS_PORT) & EC_STS_IBF)
    {
        if (--retries == 0)
            return 0xFF;
    }

    return 0;
}

//
=====
// ec_wait_obe
//
=====
uint8_t ec_wait_obe(void)
{
    uint16_t  retries = EC_RETRIES;

    // wait for the output buffer empty
    while (inb(STS_PORT) & EC_STS_OBF)
    {
        if (--retries == 0)
            return 0xFF; // timeout obe

        inb(DAT_PORT); // reading output buffer if OBF
    }

    return 0;
}

//
=====
// ec_wait_obf
//
=====
uint8_t ec_wait_obf(void)
{
    uint16_t  retries = EC_RETRIES;

    // wait for the output buffer full

```

```

while ((inb(STS_PORT) & EC_STS_OBF) == 0)
{
    if (--retries == 0)
        return 0xFF; // timeout obf
    }

return 0;
}

//
=====
=====
// ec_prot_trans
//
=====
=====
uint8_t ec_prot_trans(uint8_t cmd, uint8_t ctl, uint8_t dev, uint8_t len, uint8_t *dat)
{
    uint8_t i;
    uint8_t *datap;

    if ((cmd & EC_CMD_MASK) == EC_CMD_READ)
        memset(dat, 0, len);

    // cmd
    if (ec_wait_ibe())
        return 0xFF;
    outb(CMD_PORT, cmd);

    // ctl
    if (ec_wait_ibe())
        return 0xFF;
    outb(DAT_PORT, ctl);

    // dev
    if (ec_wait_ibe())
        return 0xFF;
    outb(DAT_PORT, dev);

    // len
    if (ec_wait_ibe())
        return 0xFF;
    outb(DAT_PORT, len);

    // dat
    datap = dat;
    if ((cmd & EC_CMD_MASK) == EC_CMD_READ)
    {

```

```

    // read command
    for (i=0; i<len; i++)
    {
        if (ec_wait_obf())
            return 0xFF;

        *datp++ = inb(DAT_PORT);
    }
}
else
{
    // write command
    for (i=0; i<len; i++)
    {
        if (ec_wait_ibe())
            return 0xFF;

        outb(DAT_PORT, *datp++);
    }
}

return 0;
}

//
=====
// ec_wdt_setup
//
=====
uint8_t ec_wdt_setup(uint8_t wdt_type, uint32_t ms)
{
    uint8_t buf[4];

    buf[0] = (ms >> 0) & 0xFF;
    buf[1] = (ms >> 8) & 0xFF;
    buf[2] = (ms >> 16) & 0xFF;
    buf[3] = (ms >> 24) & 0xFF;

    if (ec_prot_trans(WDT_CMD_WRITE, wdt_type, 0, 4, buf))
        return 0xFF;

    return 0;
}

```

```

//
=====
=====
// ec_wdt_start
//
=====
=====
uint8_t ec_wdt_start(void)
{
    uint8_t buf[2];

    buf[0] = WDT_CTL_START;

    if (ec_prot_trans(WDT_CMD_WRITE, WDT_CTL, 0, 1, buf))
        return 0xFF;

    return 0;
}

//
=====
=====
// ec_wdt_stop
//
=====
=====
uint8_t ec_wdt_stop(void)
{
    uint8_t buf[2];

    buf[0] = WDT_CTL_STOP;

    if (ec_prot_trans(WDT_CMD_WRITE, WDT_CTL, 0, 1, buf))
        return 0xFF;

    return 0;
}

//
=====
=====
// ec_wdt_clear : need to be issued before watchdog time-out
//
=====
=====
uint8_t

```

ADVANTECH

Enabling an Intelligent Planet

www.advantech.com

Please verify specifications before quoting. This guide is intended for reference purposes only.

All product specifications are subject to change without notice.

No part of this publication may be reproduced in any form or by any means, electronic, photocopying, recording or otherwise, without prior written permission of the publisher.

All brand and product names are trademarks or registered trademarks of their respective companies.

© Advantech Co., Ltd. 2018