

USER'S MANUAL

OPS520 Series

Intel Open Pluggable Specification Box

User's Manual



www.axiomtek.com

Disclaimers

This manual has been carefully checked and believed to contain accurate information. Axiomtek Co., Ltd. assumes no responsibility for any infringements of patents or any third party's rights, and any liability arising from such use.

Axiomtek does not warrant or assume any legal liability or responsibility for the accuracy, completeness or usefulness of any information in this document. Axiomtek does not make any commitment to update the information in this manual.

Axiomtek reserves the right to change or revise this document and/or product at any time without notice

No part of this document may be reproduced, stored in a retrieval system, or transmitted, in any form or by any means, electronic, mechanical, photocopying, recording, or otherwise, without the prior written permission of Axiomtek Co., Ltd.

©Copyright 2021 Axiomtek Co., Ltd.

All Rights Reserved

April 2021, Version A1

Printed in Taiwan

Safety Approvals

- CE Marking
- FCC Class A

◆ FCC Compliance

This equipment has been tested in compliance with the limits for a Class A digital device, pursuant to Part 15 of the FCC Rules. These limits are meant to provide reasonable protection against harmful interference in a residential installation. If not installed and used in accordance with proper instructions, this equipment might generate or radiate radio frequency energy and cause harmful interference to radio communications. However, there is no guarantee that interference will not occur in a particular installation. If this equipment does cause harmful interference to radio or television reception, which can be determined by turning the equipment off and on, the user is encouraged to try to correct the interference by one or more of the following methods:

- A. Increase the separation between the equipment and receiver.
- B. Connect the equipment to another outlet of a circuit that does not connect with the receiver.
- C. Consult the dealer or an experienced radio/TV technician for help.

Shielded interface cables must be used in order to comply with the emission limits.

Safety Precautions

Before getting started, please read the following important safety precautions.

1. The OPS500-520-H Series does not come equipped with an operating system. An operating system must be loaded first before installing any software into the computer.
2. Be sure to ground yourself to prevent static charge when installing the internal components. Use a grounding wrist strap and place all electronic components in any static-shielded devices. Most electronic components are sensitive to static electrical charge.
3. Disconnect the power cord from the OPS500-520-H Series before any installation. Be sure both the system and external devices turned OFF already. Make sure the OPS500-520-H Series set to ground properly.
4. The brightness of the flat panel display will be getting weaker as frequently used. However, the operating period varies depending on the application environment.
5. The flat panel display is not susceptible to shock or vibration. When assembling the OPS500-520-H Series, make sure to install it securely.
6. Do not leave this equipment in an uncontrolled environment where the storage temperature is below 0°C or above 45°C. It may damage the equipment.
7. External equipment intended for connection to signal input/out or other connectors shall comply with relevant UL/IEC standard.
8. Do not open the back cover of the system. If opening the cover for maintenance is necessary, only allow technicians to implement it. Integrated circuits on computer boards are sensitive to static electricity. To avoid damaging chips from electrostatic discharge, observe the following precautions:
9. Before handling a board or integrated circuit, touch an unpainted portion of the system unit chassis for a few seconds. This will help to discharge any static electricity on your body.
10. Please wear a wrist-grounding strap if you handling boards and electronic components.

Trademarks Acknowledgments

Axiomtek is a trademark of Axiomtek Co., Ltd.

IBM, PC/AT, PS/2, VGA are trademarks of International Business Machines Corporation.

Intel® and Atom™ are registered trademarks of Intel Corporation.

MS-DOS, Microsoft C and Quick BASIC are trademarks of Microsoft Corporation.

VIA is a trademark of VIA Technologies, Inc.

SST is a trademark of Silicon Storage Technology, Inc.

UMC is a trademark of United Microelectronics Corporation. Other brand names and trademarks are the properties and registered brands of their respective owners.

Table of Contents

Disclaimers	ii
Safety Approvals	iii
Safety Precautions	iv
SECTION 1 INTRODUCTION.....	1
1.1 General Description	1
1.2 System Specifications	2
1.2.1 Main CPU Board.....	2
1.2.2 I/O System	2
1.3 Mechanical Assembly.....	4
1.3.1 Dimensions.....	4
1.3.2 I/O outlet	5
1.3.3 Mechanical Specifications	5
1.3.4 Reference Design	11
1.4 Package List.....	12
SECTION 2 HARDWARE INSTALLATION	13
2.1 DRAM, Storage, Wireless module Installations	13
2.1.1 DDR4 SO-DIMM DRAM Installation (SO-DIMM1).....	13
2.1.2 DDR4 SO-DIMM DRAM Installation (SO-DIMM 2).....	14
2.1.3 M.2 SSD Installation	16
2.1.4 Wireless Module (M.2 Key E Card)	17
2.2 Pluggable Module Method.....	19
SECTION 3 CONNECTORS	21
3.1 Connectors.....	21
3.1.1 JAE TX25A Connector (CN1).....	23

3.1.2	CPU FAN Connector (CN3)	24
3.1.3	M.2 2230 Key E Wi-Fi & Bluetooth (CN3)	24
3.1.4	USB 2.0 Port (CN4)	25
3.1.5	USB 3.1 / USB 2.0 Stack Port (CN5)	25
3.1.6	DisplayPort Connector (CN6)	26
3.1.7	USB3.1 Type-C Port (CN7)	26
3.1.8	Audio Combo Jack (CN8)	27
3.1.9	HDMI Connector (CN9)	27
3.1.10	Power & Reset Button (CN10)	28
3.1.11	RJ45 (LAN1)	28
3.1.12	M.2 2280 Key M SSD (SCN1)	29
3.1.13	SW1 Setting	29
SECTION 4 AMI BIOS SETUP UTILITY		31
4.1	Starting	31
4.2	Navigation Keys	31
4.3	Main Menu	32
4.4	Advanced Menu	33
4.5	Chipset Menu	41
4.6	Boot Menu	42
4.7	Security Menu	43
4.8	Save & Exit Menu	44
APPENDIX A WATCHDOG TIMER		47
	Watchdog Timer Setting	47
	Using the Watchdog Function Start	47

SECTION 1 INTRODUCTION

This chapter contains general information and detailed specifications of the OPS520 Series. Chapter 1 includes the following sections:

- **General Description**
- **Specification**
- **Michanical Assembly**
- **Package List**

1.1 General Description

Intel Open Pluggable Specification (OPS) Compliance

OPS520 Series is based on the 11th generation Intel® Core™ processor on board with Intel® Q570/H510 Express Chipset platform and it also future products. The Pluggable Module is dedicated to provide an interchangeable solution to the digital signage media players with compatible connector. This document provides the module form factor, connector specification, reference thermal solution, and boundary conditions in order to ensure the functionality of the module in all compatible display panel system.

OPS520 Series meets Intel Open Pluggable Specification for design and development, simplifying system upgrade maintenance for manufacturers and developers that supports Intel® 11th Generation Core i series family, which stand for high flexible and user-friendly digital signage applications.

Easy maintenance

OPS520 Series offers a best solution for digital signage market. Compliant with Intel OPS architecture, digital signage players are capable of deploying interchangeable systems faster and easing upgrading/maintenance, while lowering costs for development and implementation. Additionally, having the ability to simply slot-in and out the unique pluggable engine box makes daily hassle easier and faster for users.

OPS520 Series has pluggable engine box design; you can change storage, DRAM and update configurations more easily

1.2 System Specifications

1.2.1 Main CPU Board

- **CPU**
 - 11th Gen. Intel® Core™ i7/i5/i3/Celeron Processors, LGA1200, 35W TDP
- **System Chipset**
 - Intel® Q570/H510 PCH
- **BIOS**
 - American Megatrends Inc. UEFI (Unified Extensible Firmware Interface).
- **System Memory**
 - Two 260-pin DDR4 2933MHz SO-DIMM, maximum up to 64GB

1.2.2 I/O System

- **Front I/O**
 - One HDMI 2.0 (Up to 4096 x 2160@60Hz)
 - One DP 1.4 (Up to 4096 x 2160@60Hz)
 - One USB ports 3.2 Gen2
 - Two USB ports 2.0
 - One USB Type-C
 - One Audio jack
 - One Power On/Off button
 - One Reset button
 - Two LED Indicators (PWR & Storage Active LED)
- **Rear I/O**
 - One 80Pin JAE TX25A
 - 1 x HDMI 2.0 (Up to 4096 x 2160@60Hz)
 - 1 x DP 1.4 (Up to 4096 x 2304@60Hz)
 -  **【Note】** : 1 x DP 1.4 will not be supported when adopting Intel Comet Lake CPU.
 - 1 x USB 3.0
 - 2 x USB 2.0
 - 1 x UART (TX/RX)
 - 1 x Audio out L/R
 - Control signals (PWR_STATUS, PS_ON#, PB_DET, SYS_FAN)
- **Ethernet**
 - 10/100/1000Mbps Ethernet (with Intel® I219-LM)
- **Expansion**
 - One M.2 2230 Key E (USB+PCIe signal supported)

- **Storage**
 - One M.2 Key M 2280 for NVMe SSD
- **Antenna opening**
 - Two Antenna openings in the front I/O side
- **Net Weight**
 - 0.9kg (1.99 lb) without cooler
- **Dimension (Main Body Size)**
 - 200 mm(W) x 119 mm(D) x 30 mm(H)
- **Operation Temperature**
 - 0°C to 45°C (with airflow 1.2 m/s)
- **Power Input**
 - 12V~19VDC



NOTE: All specifications and images are subject to change without notice.

1.3 Mechanical Assembly

1.3.1 Dimensions

This diagram shows you dimensions and outlines of the OPS520 Series

The overall dimension of the module including the mounting frame is 200mm x 119mm x 30mm, and it shows the location of the screw holes of front panel as well as the security lock.

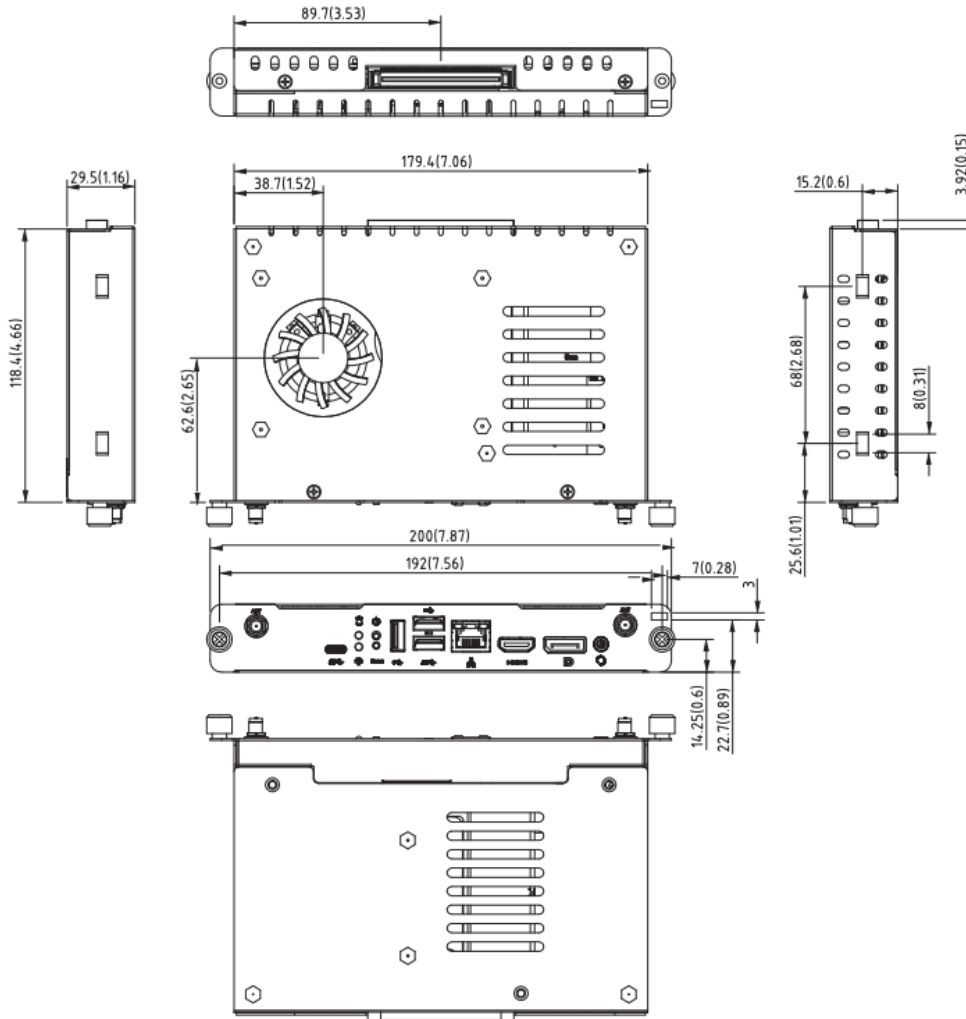

※While plugging the OPS module, please make sure the heat sink side of OPS module toward the outside. Axiomtek will be out of reasonability if there is any damage occurred due to it.



1.3.2 I/O outlet

The following figures show you the locations of the OPS520 Series I/O outlets.

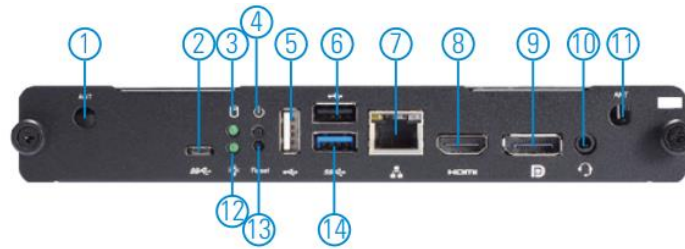

- | | | |
|----------------------|----------------|----------------------|
| 1. Optional antenna | 6. USB 2.0 | 11. Optional antenna |
| 2. USB Type-C | 7. LAN | 12. Power indicator |
| 3. Storage indicator | 8. HDMI 2.0 | 13. Reset button |
| 4. Power button | 9. DP1.4 | 14. USB 3.2 |
| 5. USB 2.0 | 10. Audio jack | 15. JAE TX-25A |



1.3.3 Mechanical Specifications

OPS520 Series is docked in the reference display panel

The OPS520 Pluggable Module docked at a display panel system.

In this reference design, the module is docked and undocked in the vertical direction.

 **NOTE:** Please contact Axiomtek for available option display panel.

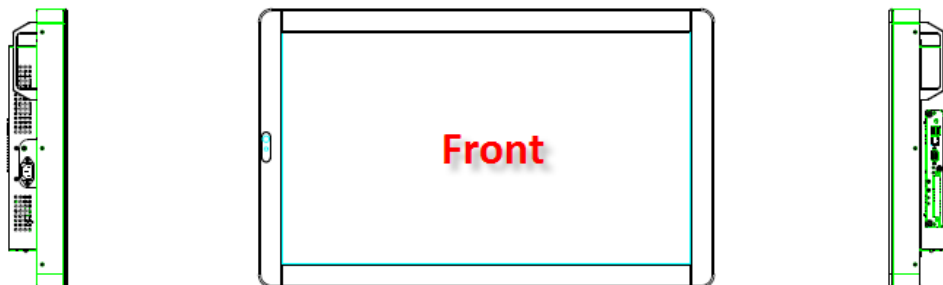
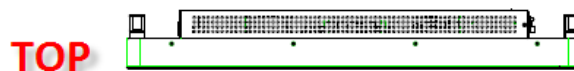

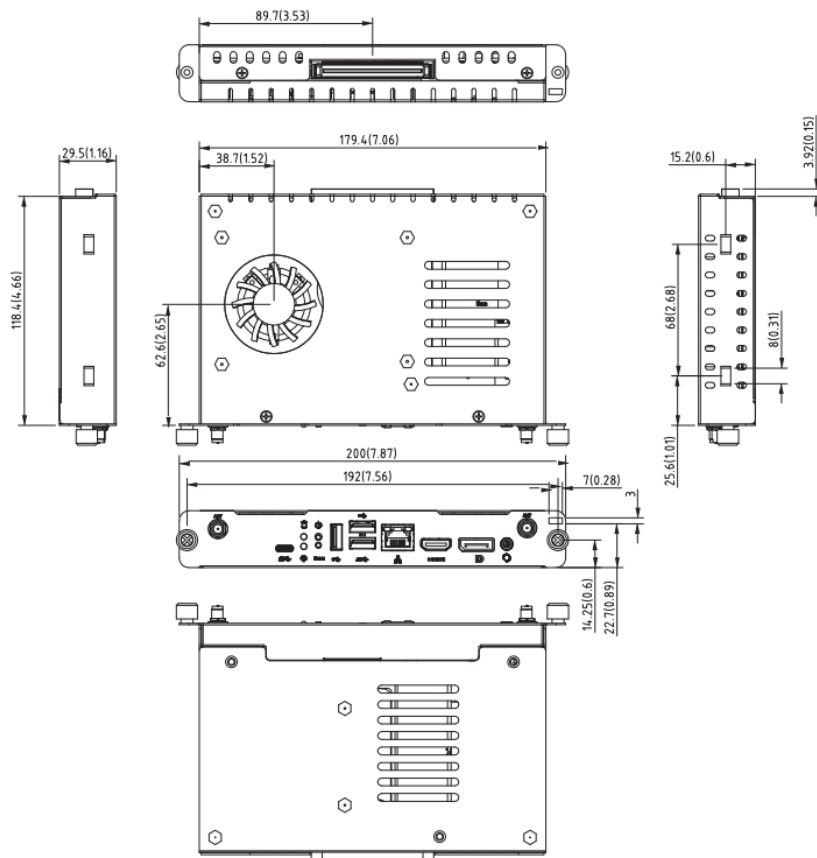

Exploded View of the Pluggable Module

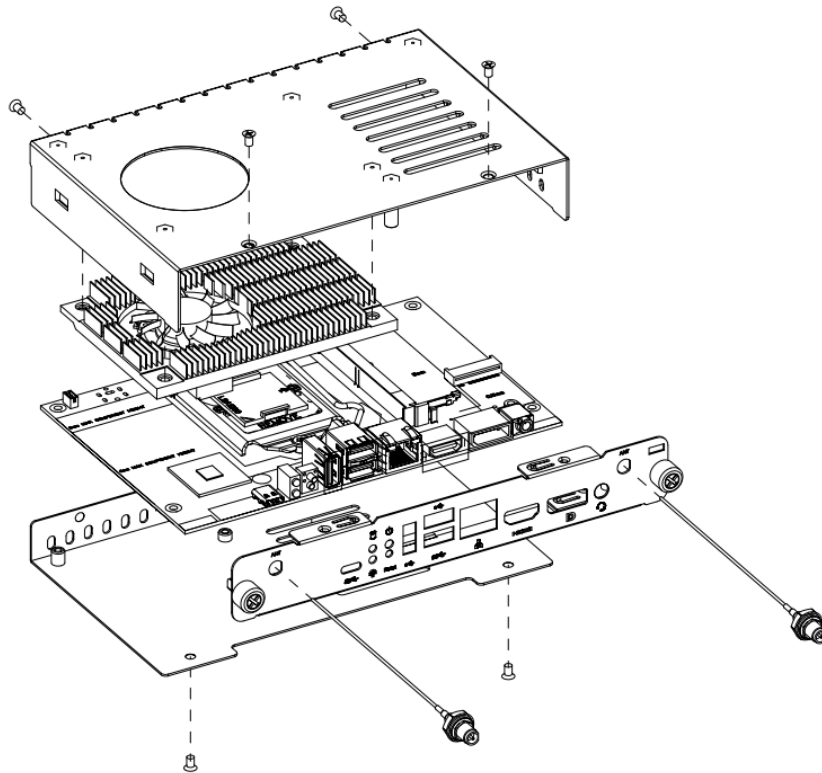

The Guide Rail Mechanism for the OPS520 Series Module

You can use the rails alongside of OPS520 Series Module to dock and undock the plug connector at the back of the module to connect with docking board. There are two lock pins on each side of the rail, and they serve as the locking mechanism to attach the lock holes on the series module.

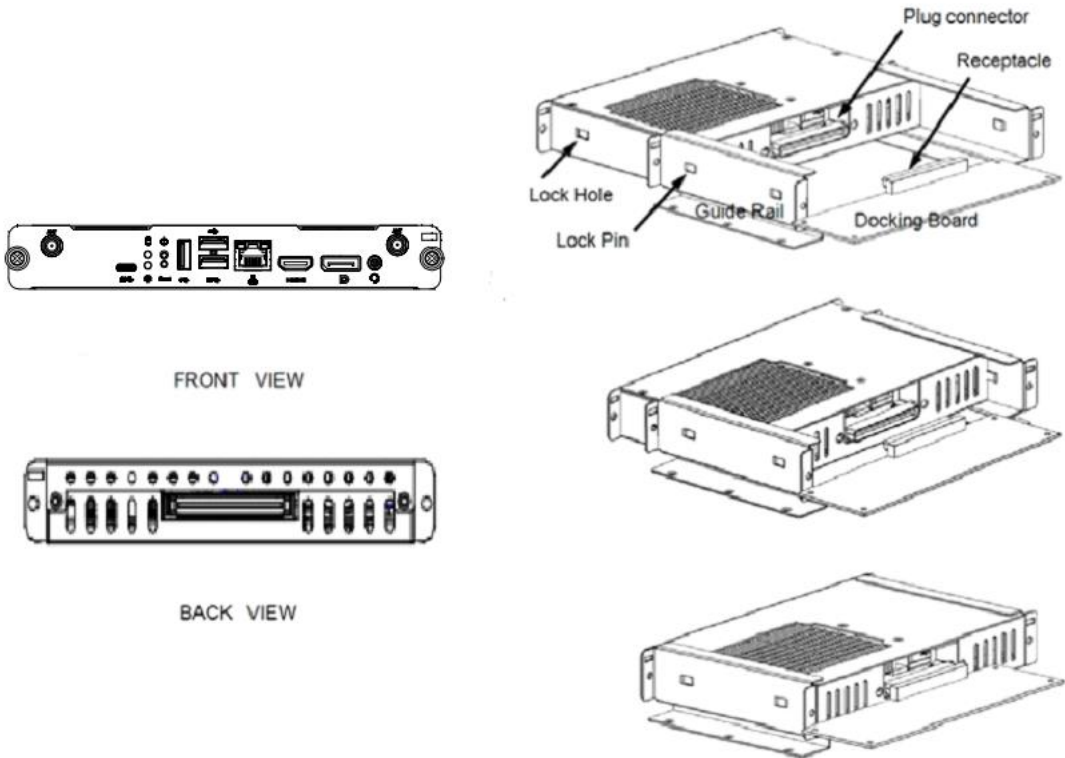

Location of Lock Hole on the Pluggable Module

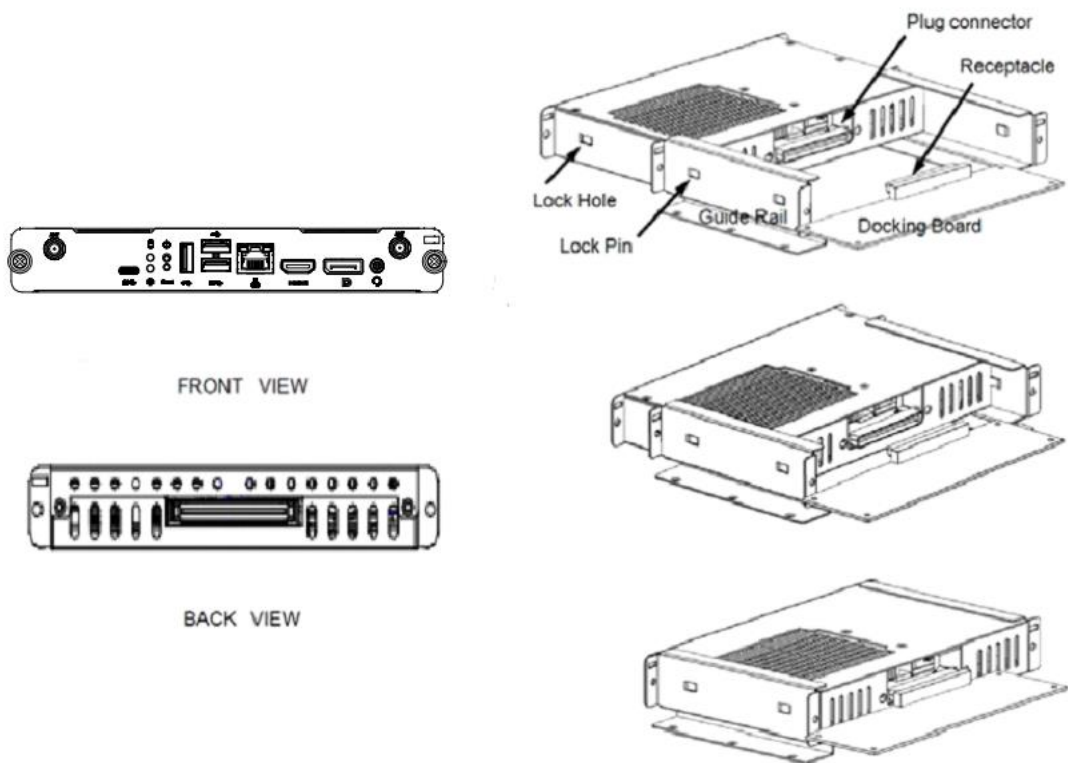

*The drawing is base on Intel Open Pluggable Specification

Dimensions of the Guide Rail

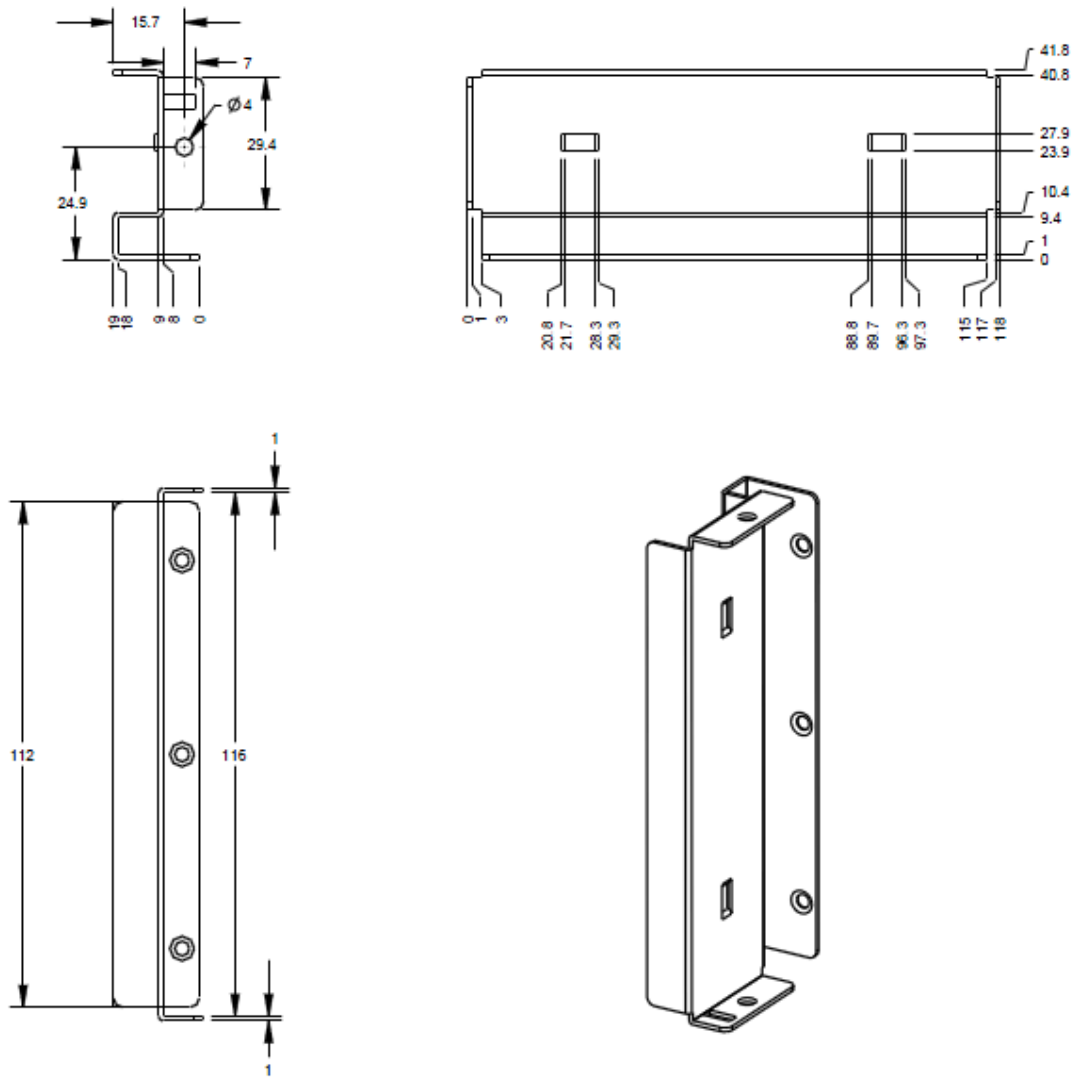

Location of JAE TX25A Plug Connector

Please refer to the following drawing for location of the JAE TX25A plug connector. Pin 1 of the connector is located at 114.8 mm from the edge of the module, and 106.9 mm from the inner side of the front panel. For mating tolerance of TX25A plug connector and TX24A receptacle connector, please refer to the JAE improved connector specification

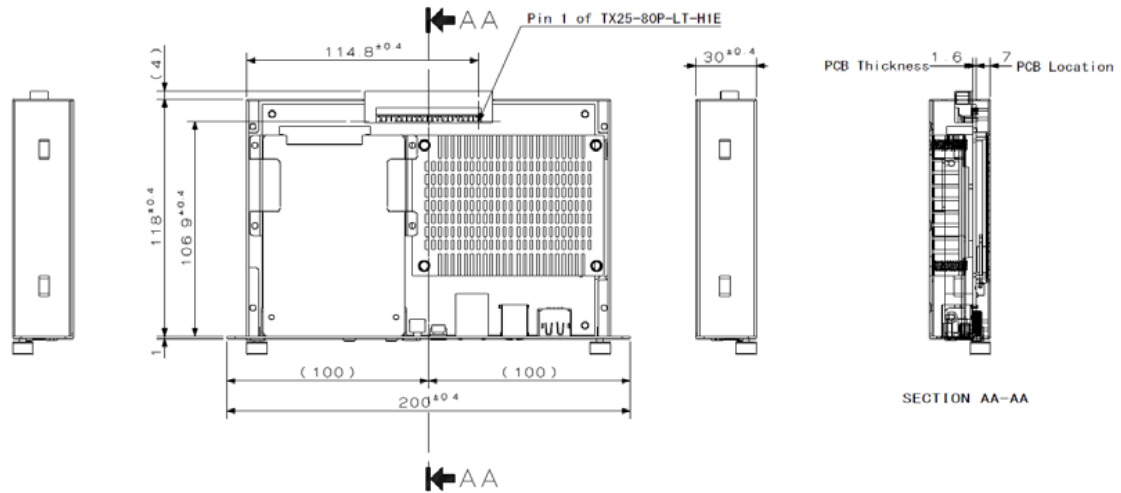

Vent Holes at the Pluggable Module Back Panel

On the OPS520 Series module, it is recommended by Intel that some vent holes be opened at the back so that hot air can escape more easily from the module that the FAR in on both sides of the module back panel should be greater than 0.25.

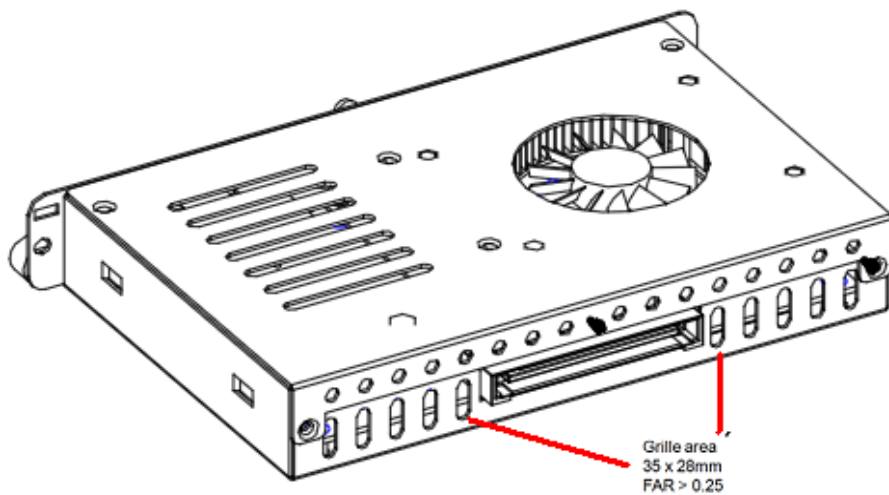

1.3.4 Reference Design

Display Panel Rear View – Internal

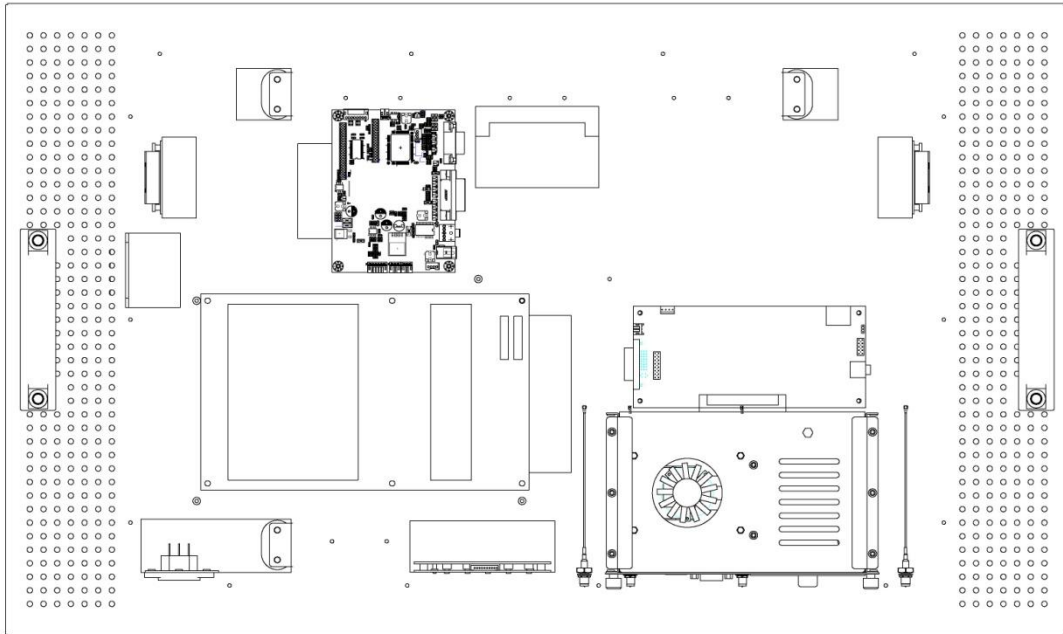

The digital signage OPS520 Series prototype is based on a **32"** display panel with the functional blocks illustrated. It is mainly a 3-board partitioning design consisting of the pluggable module, docking board and the panel control board.

1.4 Package List

When you receive the OPS520 Series, the bundled package should contain the following items:

- **OPS500-520-H x 1**
- **Quick Manual x 1**
- **Thermal Grease (Syringe 1G) x 1**
- **M.2 Thermal Pad x 1**

If you cannot find the package or any items are missing, please contact Axiomtek distributors immediately.

SECTION 2 HARDWARE INSTALLATION

The OPS520 Series is convenient for your various hardware configurations, such as Storage, Memory Module.

The chapter 2 will show you how to install the hardware. It includes:

- **DRAM, SSD, Wireless module Installation**
- **Pluggable Module Method**

2.1 DRAM, Storage, Wireless module Installations

The OPS520 Series model offers a convenient drive bay module for users to DDR4 SO-DIMM DRAM, M.2 2280 Key M SSD Storage and wireless modules. Please follow the steps as below:

2.1.1 DDR4 SO-DIMM DRAM Installation (SO-DIMM1)

Step 1 Turn the system upside down to locate screws at the chassis as red marked and loosen five screws.



Step 2 Slide the bottom chassis out of the module, and locate the SO-DIMM socket on the board.

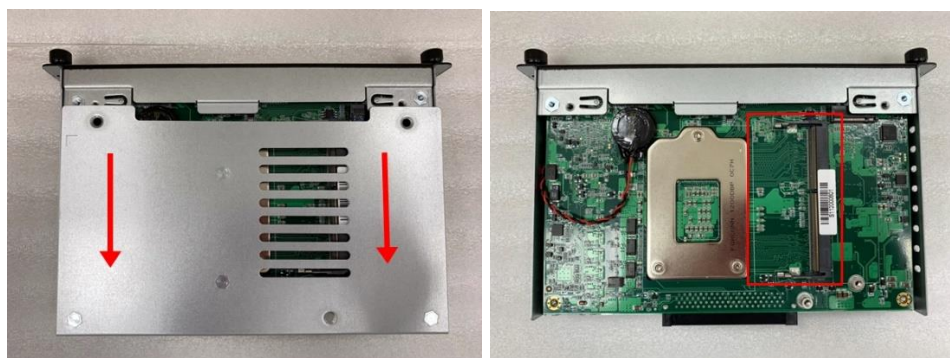

Step 3 Place the memory module into the socket and press it firmly. The socket latches are levered upwards and clipped on to the edges of the SO-DIMM.

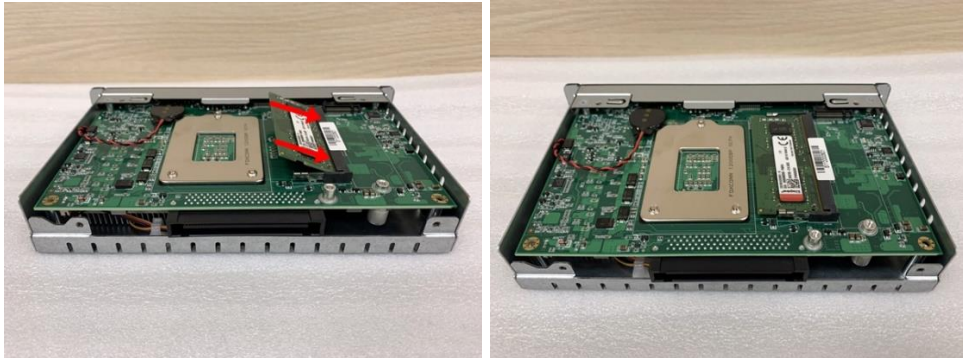

2.1.2 DDR4 SO-DIMM DRAM Installation (SO-DIMM 2)

Step 1 Locate screws at the chassis as red marked and loosen four screws.

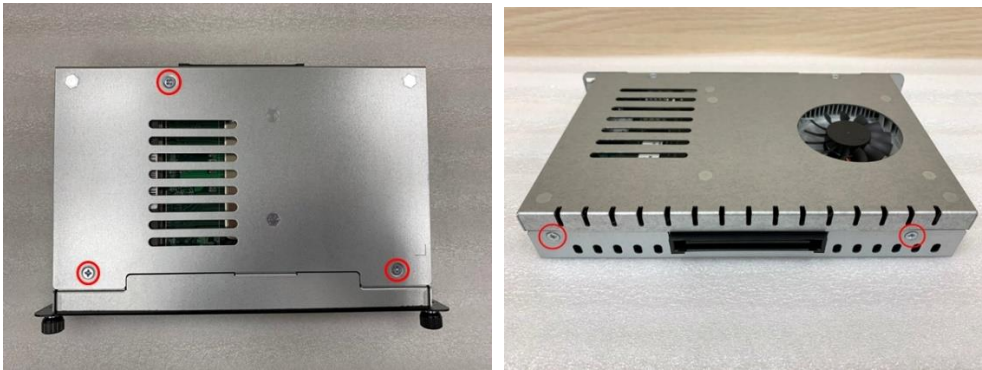

Step 2 To open the upper case, please hold the system with your middle fingers at the Lock Hole, and put your thumbs at the edge of the front panel, then use your thumbs press enough force at the edge of the front panel (①red arrow in the second figure below), meanwhile; lift up the upper case with your middle fingers (②blue arrow in the second figure below).

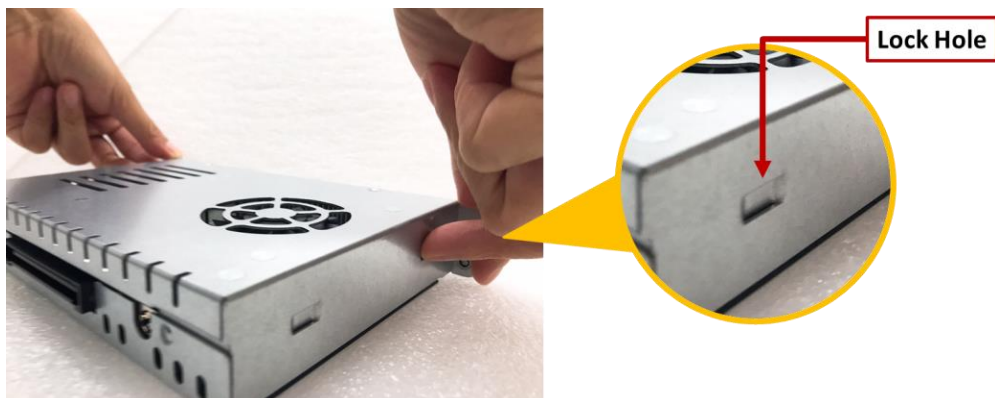

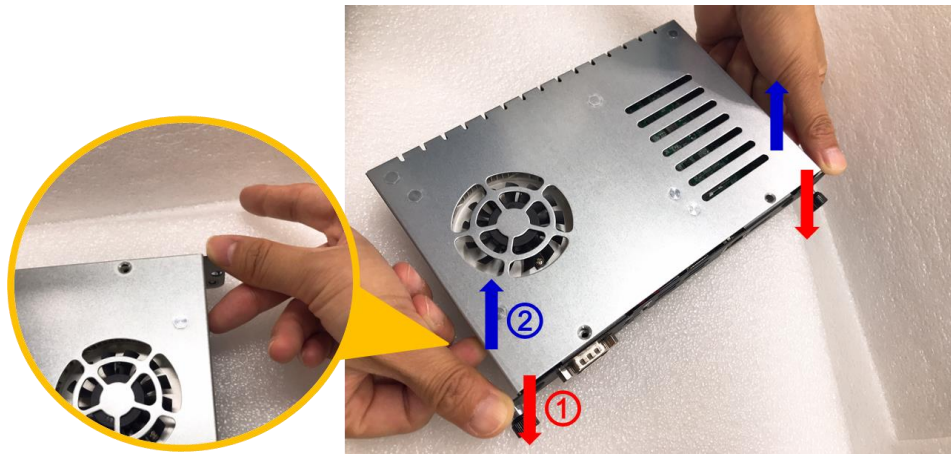

Step 3 Place the memory module into the socket and press it firmly. The socket latches are levered upwards and clipped on to the edges of the SO-DIMM.

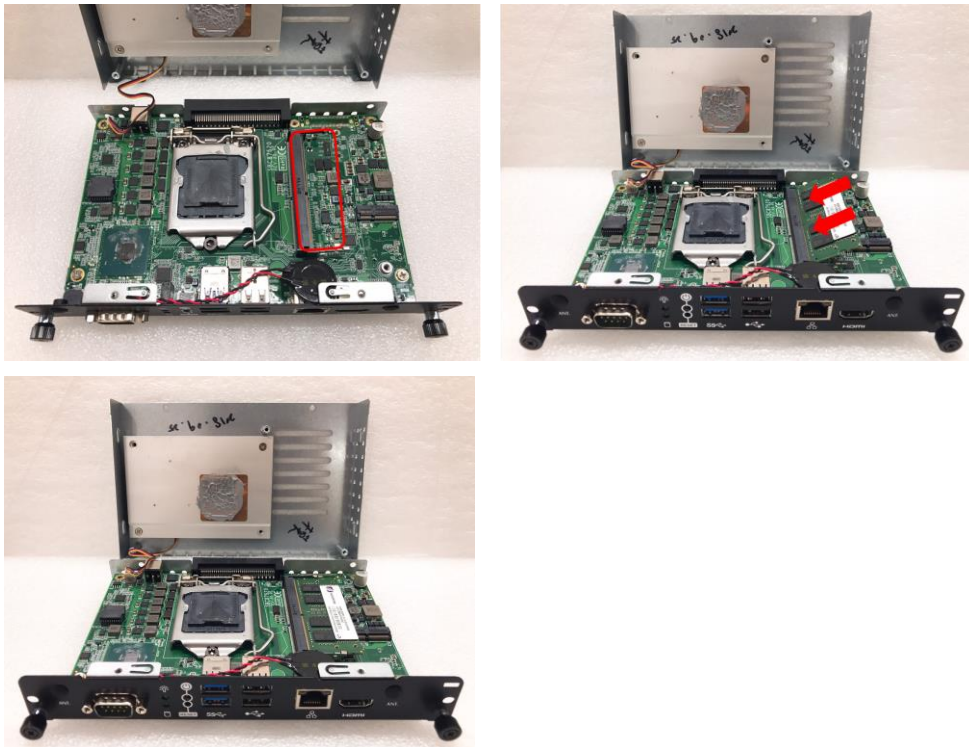

2.1.3 M.2 SSD Installation

The OPS520 Series provides one M.2 Key M 2280 socket to install M.2 SSD. Please refer to the following instructions and illustration.

Step 1 Turn the system upside down to locate screws at the chassis as red marked and loosen five screws.

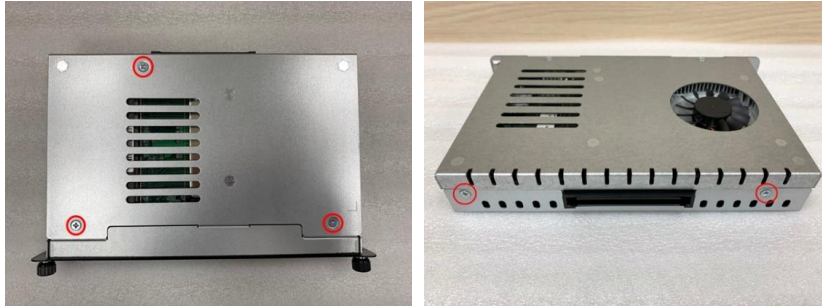

Step 2 Slide the bottom chassis out of the module, and locate the M.2 2280 Key M slot on the board.

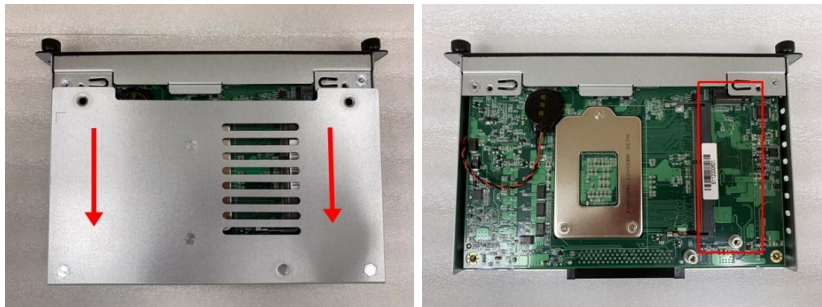

Step 3 Holding the M.2 2280 Key M SSD card at a 30 degree angle up from horizontal, slowly insert the golden fingers into the M.2 2280 Key M slot until it is fully inserted in. And secure the M.2 2280 Key M SSD card to the carrier by tightening up the one M3*4L pan head screw to the marked position.

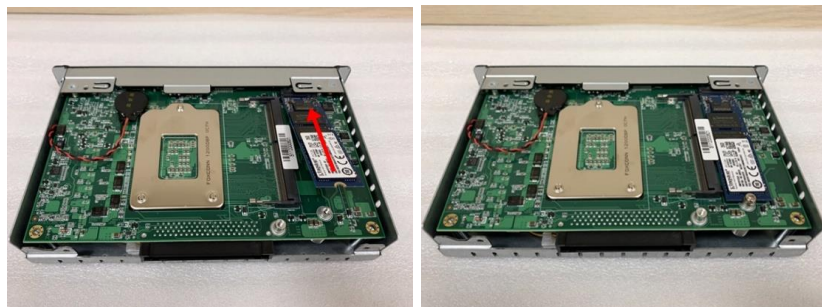

Step 4 Then apply the M.2 thermal pad on the M.2 2280 Key M SSD card.

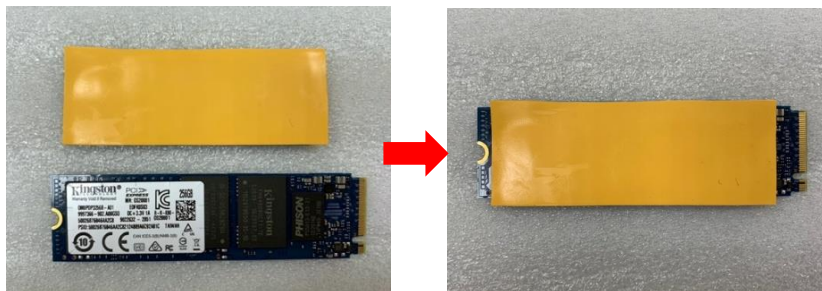

2.1.4 Wireless Module (M.2 Key E Card)

The OPS520 Series provides one M.2 Key E Socket for user to install M.2 Key E Card, please refer to the following instructions and illustration.

Step 1 Locate screws at the chassis as red marked and loosen four screws.

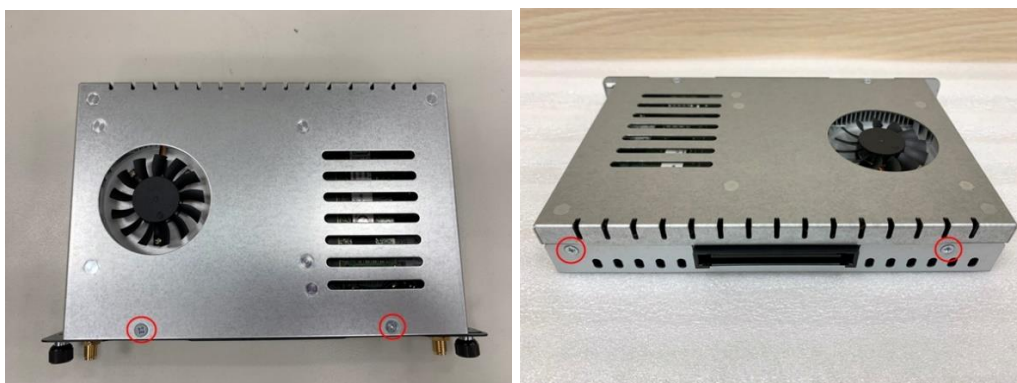

Step 2 To open the upper case, please hold the system with your middle fingers at the Lock Hole, and put your thumbs at the edge of the front panel, then use your thumbs press enough force at the edge of the front panel (①red arrow in the second figure below), meanwhile; lift up the upper case with your middle fingers (②blue arrow in the second figure below).

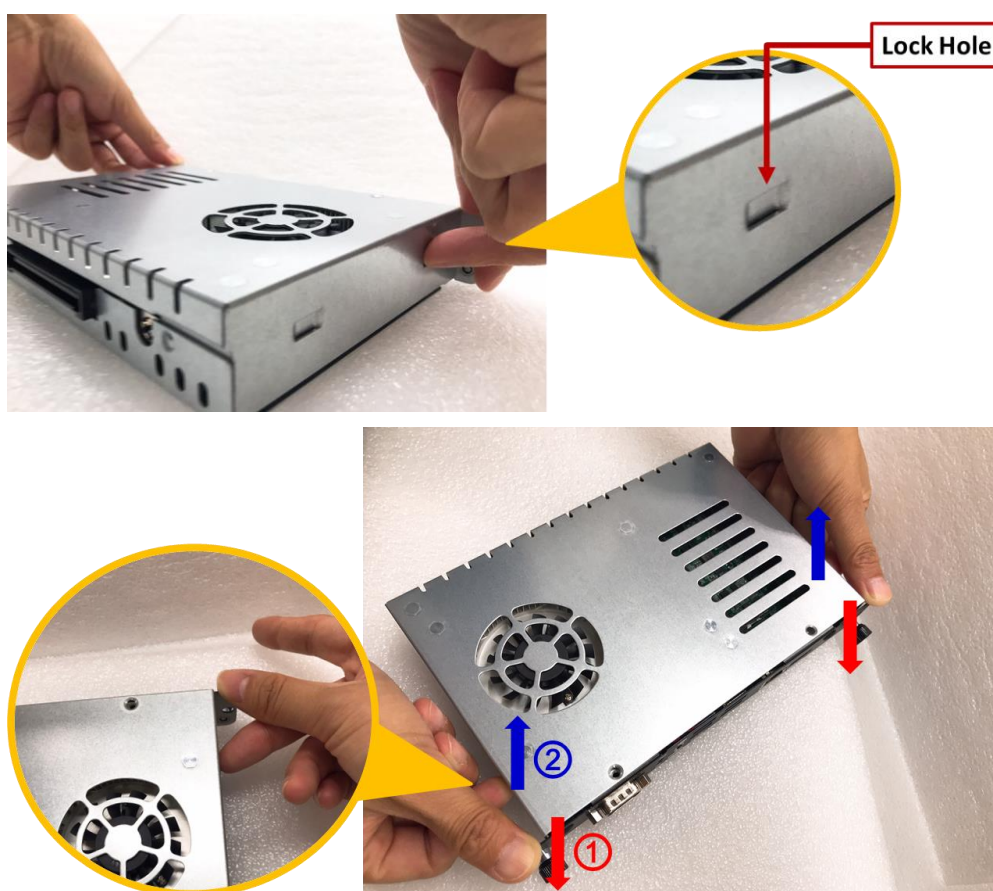

- Step 3** Locate the M.2 2230 Key E slot on the board. And holding the M.2 2230 Key E card at a 30 degree angle up from horizontal, slowly insert the golden fingers into the M.2 2230 Key E slot until it is fully inserted in.



- Step 4** Then secure the M.2 2230 Key E Wi-Fi Module to the carrier by tightening up the one M3*4L pan head screw to the marked position.



2.2 Pluggable Module Method



NOTE: Please contact Axiomtek for the available option display



Step 1 Pluggable the box into display

Caution: When plugging OPS520 Series module into an OPS display, make sure the module's heat sink is facing outside of the display. Axiomtek is not responsible for any damage caused by wrong installation.

Step 2 Fasten the screws as illustrated.

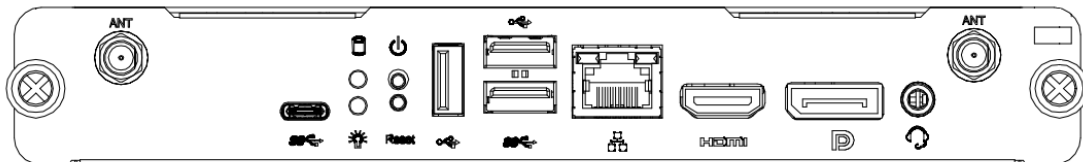

This page is intentionally left blank.

SECTION 3 CONNECTORS

This chapter provides users with detailed description how to set up basic system configuration through the AMIBIOS8 BIOS setup utility.

3.1 Connectors

Connectors connect this board with other parts of the system. Loose or improper connection might cause problems. Make sure all connectors are properly connected.

Here is a summary table shows you all connectors on the board.

External Connectors / Buttons	PCB Location	Section
JAE TX25A Connector	CN1	3.1.1
CPU FAN Connector	CN2	3.1.2
M.2 2230 Key E Wi-Fi & Bluetooth	CN3	3.1.3
USB2.0 Port	CN4	3.1.4
USB3.1 / USB2.0 Stack Port	CN5	3.1.5
DisplayPort Connector	CN6	3.1.6
USB3.1 Type-C Port	CN7	3.1.7
Audio Jack	CN8	3.1.8
HDMI Connector	CN9	3.1.9
Power & Reset Button	CN10	3.1.10
RJ45	LAN1	3.1.11
M.2 2280 Key M Slot	SCN1	3.1.12
AT/ATX Mode	SW1	3.1.13
CMOS Clear		

Board Layout

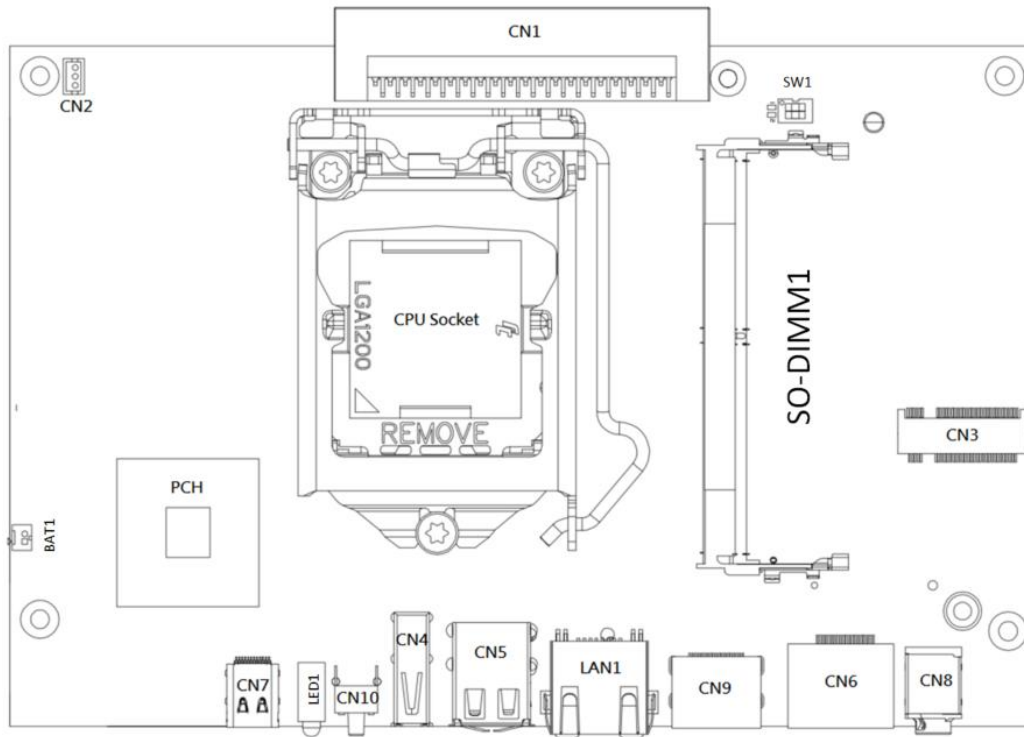

Top side

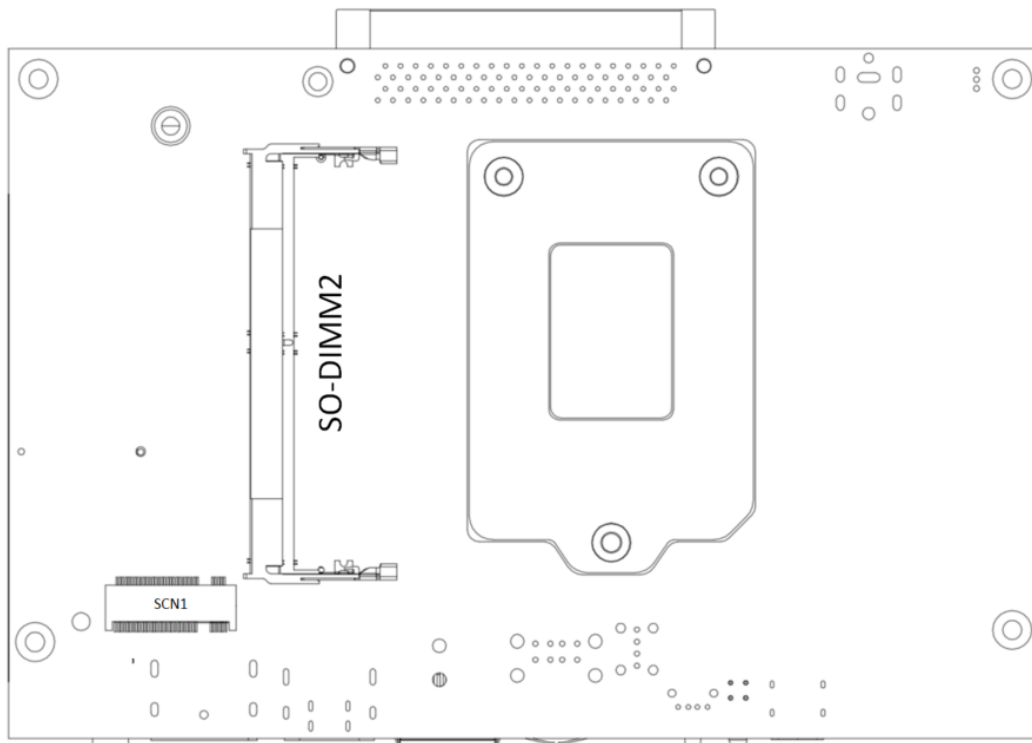

Bottom side

3.1.1 JAE TX25A Connector (CN1)

Connector JAE TX25A CN1 is for JAE improved interface supported.

Pin	Signal	Pin	Signal	Pin	Signal	Pin	Signal
1	DDP_3N	2	DDP_3P	3	GND	4	DDP_2N
5	DDP_2P	6	GND	7	DDP_1N	8	DDP_1P
9	GND	10	DDP_0N	11	DDP_0P	12	GND
13	DDP_AUXN	14	DDP_AUXP	15	DDP_HPDP	16	GND
17	TMDS_CLK-	18	TMDS_CLK+	19	GND	20	TMDS0-
21	TMDS0+	22	GND	23	TMDS1-	24	TMDS1+
25	GND	26	TMDS2-	27	TMDS2+	28	GND
29	DVI_DDC_DAT A	30	DVI_DDC_CLK	31	DVI_HPDP	32	GND
33	+12V~+19V	34	+12V~+19V	35	+12V~+19V	36	+12V~+19V
37	+12V~+19V	38	+12V~+19V	39	+12V~+19V	40	+12V~+19V
41	RSVD	42	RSVD	43	RSVD	44	RSVD
45	RSVD	46	RSVD	47	RSVD	48	RSVD
49	SLP_S3	50	SYS_FAN	51	UART_RXD	52	UART_TXD
53	GND	54	StdA_SSRX-	55	StdA_SSRX+	56	GND
57	StdA_SSTX-	58	StdA_SSTX+	59	GND	60	USB_PN2
61	USB_PP2	62	GND	63	USB_PN1	64	USB_PP1
65	GND	66	USB_PN0	67	USB_PP0	68	GND
69	AZ_LINEOUT_ L	70	AZ_LINEOUT_ R	71	NC	72	PB_DET
73	PS_ON#	74	PWR_STATUS	75	GND	76	GND
77	GND	78	GND	79	GND	80	GND

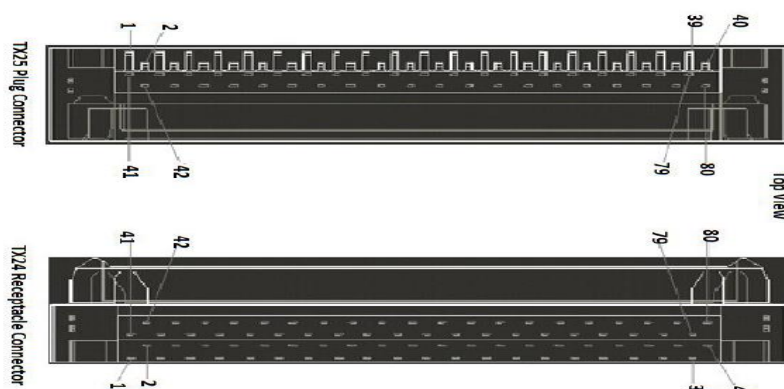

3.1.2 CPU FAN Connector (CN3)

CN3 provides power input and FAN control signal, and you can connect CPU FAN through this connector.

Pin	Signal
1	GND
2	FAN CTRL
3	FAN DET

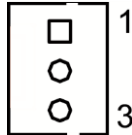

3.1.3 M.2 2230 Key E Wi-Fi & Bluetooth (CN3)

CN4 for PCI-Express and USB signals interface supported Socket 1 · Key E · type 2230.

Pin	Signal	Pin	Signal	Pin	Signal	Pin	Signal
1	GND	2	+3.3V	3	USB_D+	4	+3.3V
5	USB_D-	6	NC	7	GND	8	NC
9	NC	10	NC	11	NC	12	NC
13	NC	14	NC	15	NC	16	NC
17	NC	18	GND	19	NC	20	NC
21	NC	22	NC	23	NC	24	CONNECTOR KEY E
25	CONNECTOR KEY E	26	CONNECTOR KEY E	27	CONNECTOR KEY E	28	CONNECTOR KEY E
29	CONNECTOR KEY E	30	CONNECTOR KEY E	31	CONNECTOR KEY E	32	NC
33	GND	34	NC	35	PETp0	36	NC
37	PETn0	38	NC	39	GND	40	NC
41	PERp0	42	NC	43	PERn0	44	NC
45	GND	46	NC	47	REFCLKp0	48	NC
49	REFCLKn0	50	SUSCLK	51	GND	52	PERST0#
53	CLKREQ0#	54	W_DISABLE2#	55	PEWAKE0#	56	W_DISABLE1#
57	GND	58	I2C_DATA	59	NC	60	I2C_CLK
61	NC	62	ALERT#	63	GND	64	NC
65	NC	66	NC	67	NC	68	NC
69	GND	70	NC	71	NC	72	+3.3V
73	NC	74	+3.3V	75	GND		

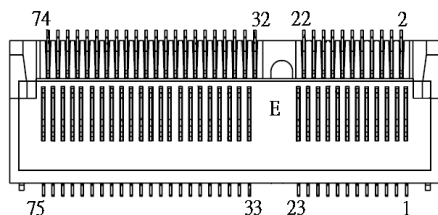

3.1.4 USB 2.0 Port (CN4)

The Universal Serial Bus connectors are compliant with USB 2.0, and ideally for installing USB peripherals such as keyboard, mouse, scanner, etc.

Pin	Signal
1	USB_POWER
2	USB D0-
3	USB D0+
4	GND



3.1.5 USB 3.1 / USB 2.0 Stack Port (CN5)

The Universal Serial Bus connectors are compliant with USB 3.1 and USB 2.0, and ideally for installing USB peripherals such as keyboard, mouse, scanner, etc.

Pin	Signal
1	USB3_POWER
2	USB D0-
3	USB D0+
4	GND
5	USB3_SSRX0-
6	USB3_SSRX0+
7	GND
8	USB3_SSTX0-
9	USB3_SSTX0+
10	USB3_POWER
11	USB D1-
12	USB D1+
13	GND

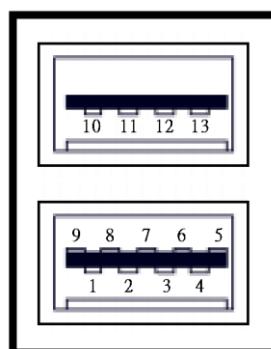

3.1.6 DisplayPort Connector (CN6)

The DP is a digital display interface which is capable of transmitting high-definition video and high-resolution audio.

Pin	Signal	Pin	Signal
1	DP_DATA0+	2	GND
3	DP_DATA0-	4	DP_DATA1+
5	GND	6	DP_DATA1-
7	DP_DATA2+	8	GND
9	DP_DATA2-	10	DP_DATA3+
11	GND	12	DP_DATA3-
13	NC	14	GND
15	DP_AUX+	16	GND
17	DP_AUX-	18	DP_HPD
19	GND	20	+3.3V

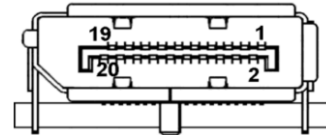

3.1.7 USB3.1 Type-C Port (CN7)

The Universal Serial Bus (compliant with USB 3.1) type C connectors for installing USB peripherals such as keyboard, mouse, scanner, etc.

Pin	Signal	Pin	Signal
A1	GND	B1	GND
A2	USB3_SSTX0+	B2	USB3_SSTX1+
A3	USB3_SSTX0-	B3	USB3_SSTX1-
A4	USB3_POWER	B4	USB3_POWER
A5	NC	B5	NC
A6	USB D0+	B6	USB D0+
A7	USB D0-	B7	USB D0-
A8	NC	B8	NC
A9	USB3_POWER	B9	USB3_POWER
A10	USB3_SSRX0-	B10	USB3_SSRX1-
A11	USB3_SSRX0+	B11	USB3_SSRX1+
A12	GND	B12	GND

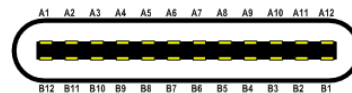

3.1.8 Audio Combo Jack (CN8)

The system provides one HD audio 4-poles jack headset connector.

Pin	Signal
1	SLEEVE
2	LINE_L
3	RING
4	LINE_R
5	GND
6	HPOUT_JD

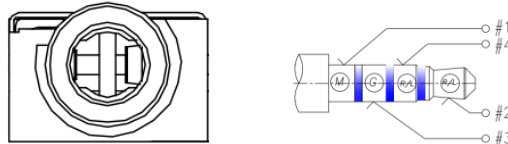

3.1.9 HDMI Connector (CN9)

The HDMI (High-Definition Multimedia Interface) is a compact digital interface which is capable of transmitting high-definition video and high-resolution audio over a single cable.

Pin	Signal	Pin	Signal
1	HDMI OUT_DATA2+	2	GND
3	HDMI OUT_DATA2-	4	HDMI OUT_DATA1+
5	GND	6	HDMI OUT_DATA1-
7	HDMI OUT_DATA0+	8	GND
9	HDMI OUT_DATA0-	10	HDMI OUT Clock+
11	GND	12	HDMI OUT Clock-
13	N.C.	14	N.C.
15	HDMI OUT_SCL	16	HDMI OUT_SDA
17	GND	18	+5V
19	HDMI-HTPLG		

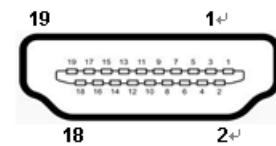

3.1.10 Power & Reset Button (CN10)

The CN10 comes with one power button and one reset button. The reset button is for rebooting your computer instead of turning OFF the power switch. It is a better way to reboot your system for a longer life of the system's power supply.

Pin	Signal
1	GND
2	GND
3	RST_BTN
4	PWR_BTN
5	GND
6	GND

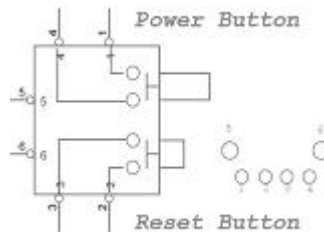

3.1.11 RJ45 (LAN1)

The RJ-45 connector LAN1 is for Ethernet. To connect the board to 100-Base-T or 1000-Base-T hub, just plug one end of the cable into LAN1 and connect the other end (phone jack) to a 100-Base-T hub or 1000-Base-T hub.

Pin	Signal
1	Tx+ (Data transmission positive)
2	Tx- (Data transmission negative)
3	Rx+ (Data reception positive)
4	RJ-1(For 1000 base T-Only)
5	RJ-1(For 1000 base T-Only)
6	Rx- (Data reception negative)
7	RJ-1(For 1000 base T-Only)
8	RJ-1(For 1000 base T-Only)
A	Active LED
B	Speed LED

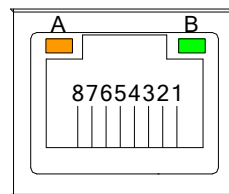

3.1.12 M.2 2280 Key M SSD (SCN1)

The OPS520 comes with one M.2 2280 Key M NvME SSD for storage.

Pin	Signal	Pin	Signal	Pin	Signal	Pin	Signal
1	GND	2	+3.3V	3	GND	4	+3.3V
5	NC	6	NC	7	NC	8	NC
9	GND	10	LED_1#	11	NC	12	+3.3V
13	NC	14	+3.3V	15	GND	16	+3.3V
17	NC	18	+3.3V	19	NC	20	NC
21	GND	22	NC	23	NC	24	NC
25	NC	26	NC	27	GND	28	NC
29	NC	30	NC	31	NC	32	NC
33	GND	34	NC	35	NC	36	NC
37	NC	38	NC	39	GND	40	NC
41	SATA-B+	42	NC	43	SATA-B-	44	NC
45	GND	46	NC	47	SATA-A-	48	NC
49	SATA-A+	50	NC	51	GND	52	NC
53	NC	54	NC	55	NC	56	NC
57	GND	58	NC	59	CONNECTOR Key M	60	CONNECTOR Key M
61	CONNECTOR Key M	62	CONNECTOR Key M	63	CONNECTOR Key M	64	CONNECTOR Key M
65	CONNECTOR Key M	66	CONNECTOR Key M	67	NC	68	NC
69	NC	70	+3.3V	71	GND	72	+3.3V
73	GND	74	+3.3V	75	GND		

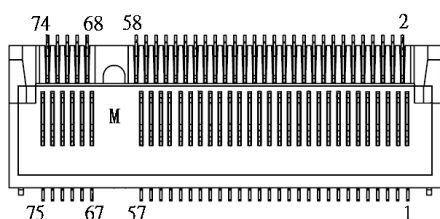

3.1.13 SW1 Setting

ATX/AT Mode and CMOS Clear can be set through SW1.

Pin	Description	ON	OFF (Default)
1	AT / ATX Mode	AT	ATX
2	CMOS Clear	Clear CMOS	Normal



Power LED

The Power LED lights up when the system is powered ON

Storage Activity LED

This connection is linked to hard drive activity LED on the control panel. LED flashes when Storage is being accessed.

SECTION 4 AMI BIOS SETUP UTILITY

This chapter provides users with detailed description how to set up basic system configuration through the AMIBIOS8 BIOS setup utility.

4.1 Starting

To enter the setup screens, follow the steps below:

- **Turn on the computer and press the key immediately.**
- **After you press the key, the main BIOS setup menu displays. You can access the other setup screens from the main BIOS setup menu, such as the Chipset and Power menus.**

4.2 Navigation Keys

The BIOS setup/utility uses a key-based navigation system called hot keys. Most of the BIOS setup utility hot keys can be used at any time during the setup navigation process.

These keys include <F1>, <F2>, <Enter>, <ESC>, <Arrow> keys, and so on.



NOTE: Some of navigation keys differ from one screen to another.

Hot Key	Description
← →Left/Right	The Left <Arrow> keys allow you to select a setup screen.
↑↓ Up/Down	The Up and Down <Arrow> keys allow you to select a setup screen or sub-screen.
+– Plus/Minus	The Plus and Minus <Arrow> keys allow you to change the field value of a particular setup item.
Tab	The <Tab> key allows you to select setup fields.
F1	The <F1> key allows you to display the General Help screen.
F2	The <F2> key allows you to Load Previous Values.
F3	The <F3> key allows you to Load Optimized Defaults.
F4	The <F4> key allows you to save any changes you have made and exit Setup. Press the <F4> key to save your changes.
Esc	The <Esc> key allows you to discard any changes you have made and exit the Setup. Press the <Esc> key to exit the setup without saving your changes.
Enter	The <Enter> key allows you to display or change the setup option listed for a particular setup item. The <Enter> key can also allow you to display the setup sub- screens.

4.3 Main Menu

When you first enter the Setup Utility, you will enter the Main setup screen. You can always return to the Main setup screen by selecting the Main tab. There are two Main Setup options. They are described in this section. The Main BIOS Setup screen is shown below.

- **BIOS Information**

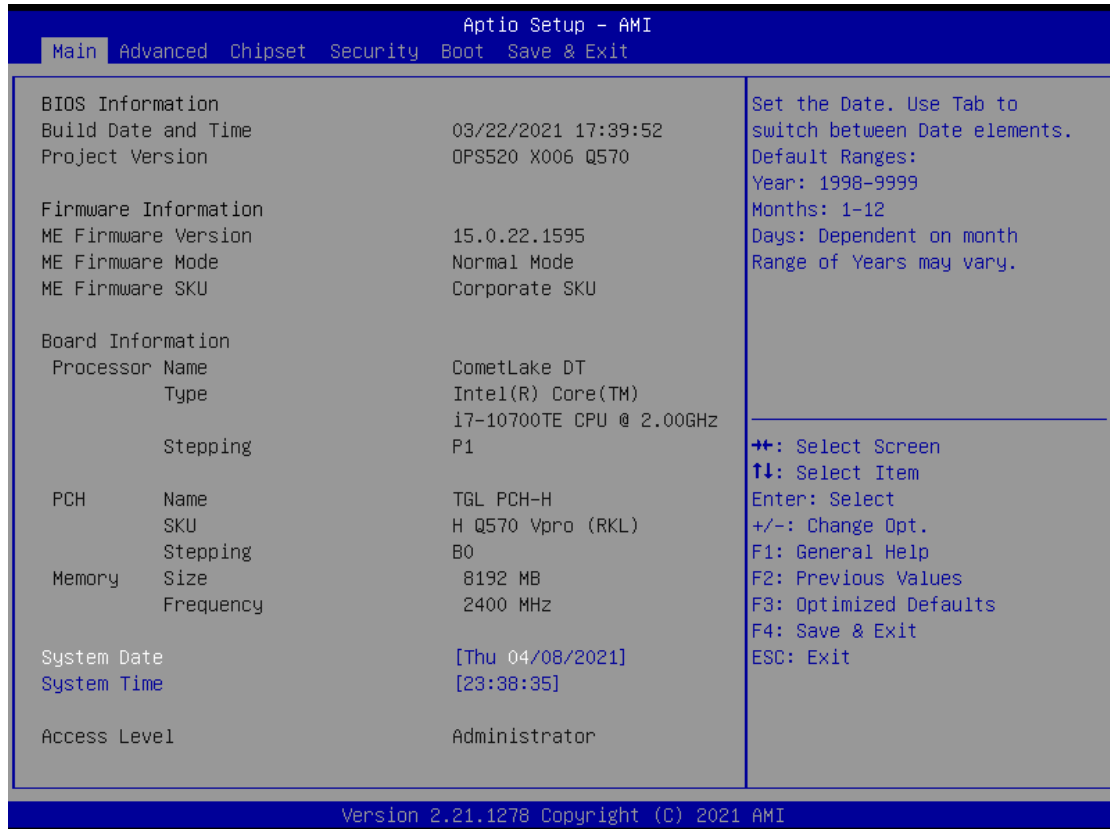

➤ **System Date/Time**

Use this option to change the system date and time. Highlight System Date or System Time using the <Arrow> keys. Enter new values through the Keyboard. Press the <Tab> key or the <Enter> keys to move between fields. The date must be entered in MM/DD/YY format. The time is entered in HH:MM:SS format.

4.4 Advanced Menu

The Advanced menu also allows users to set configuration of the CPU and other system devices. You can select any of the items in the left frame of the screen to go to the sub menus:

- **NCT5525D Super IO Configuration**
- **Hardware Monitor**
- **Trusted Computing**
- **CPU Configuration**
- **Storage Configuration**
- **USB Configuration**
- **CSM Configuration**

For items marked with “▶”, please press <Enter> for more options.

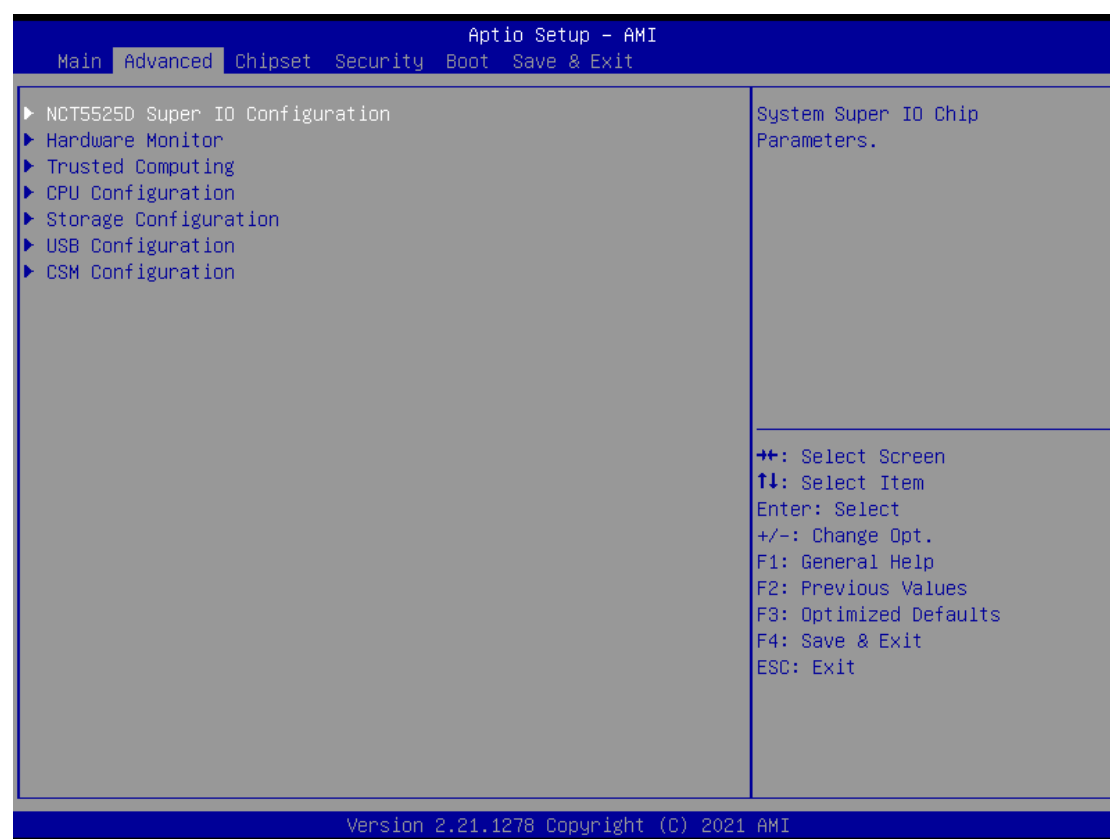

- **NCT5525D Super IO Configuration**

Set parameters of Serial Port

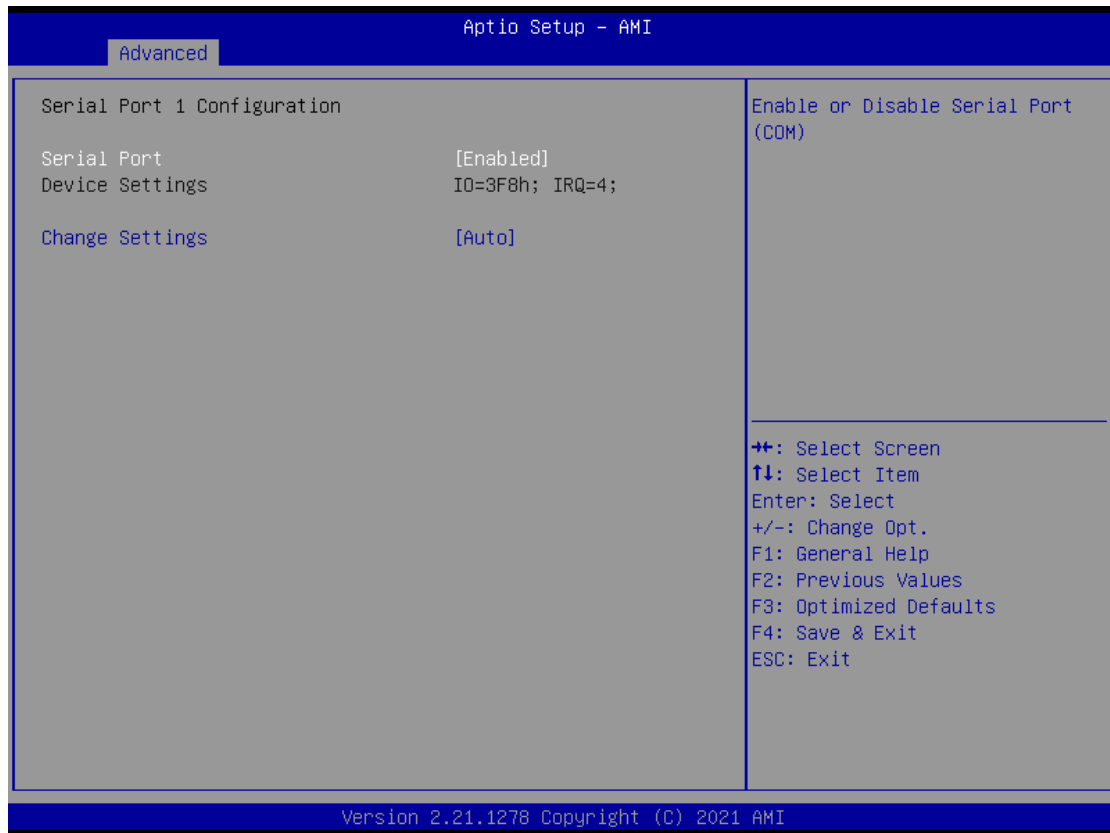

- **Serial Port**
Enable or Disable serial port.
- **Device Settings**
Display the serial port resource.

- **Hardware Monitor**

This screen shows the Hardware Configuration and enable or disable smart fan.

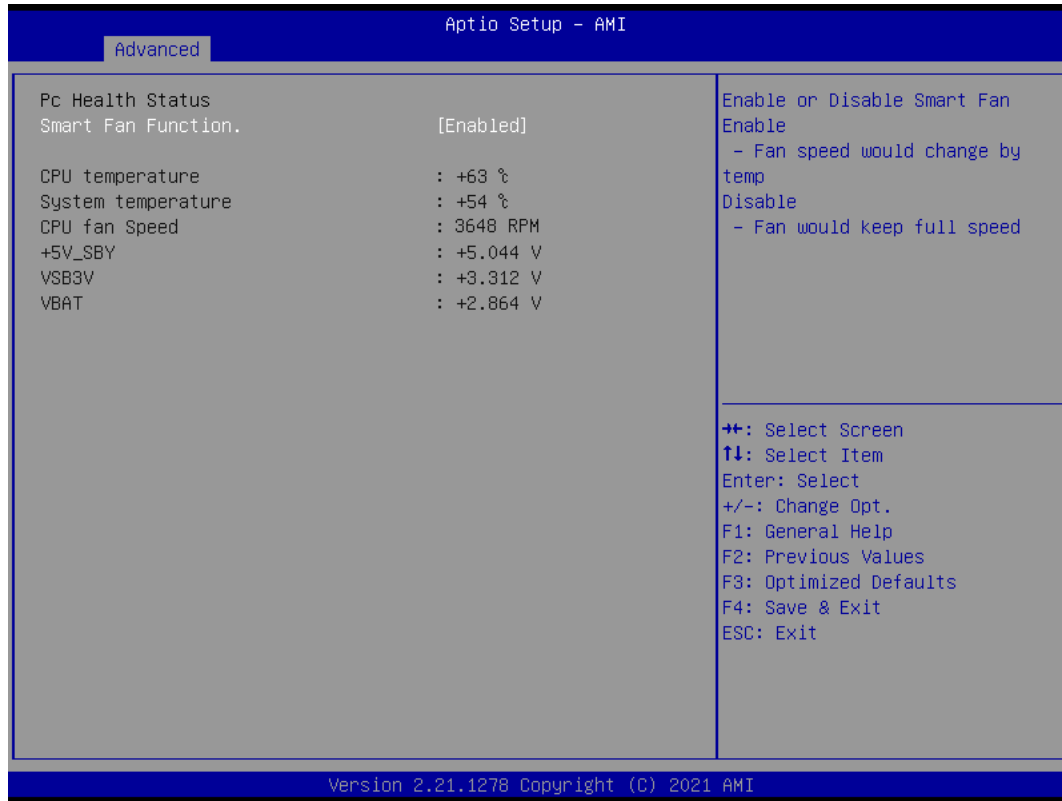

- **Smart Fan Function**

Enable or Disable Smart Fan.

● **Trusted Computing**

This screen provides function for specifying the TPM(Trusted Platform Module) settings.



➤ **Security Device Support**

Use this item to enable or disable TPM(Trusted Platform Module) function.

- **CPU Configuration**

This screen shows the CPU Configuration, and you can change the value of the selected option.

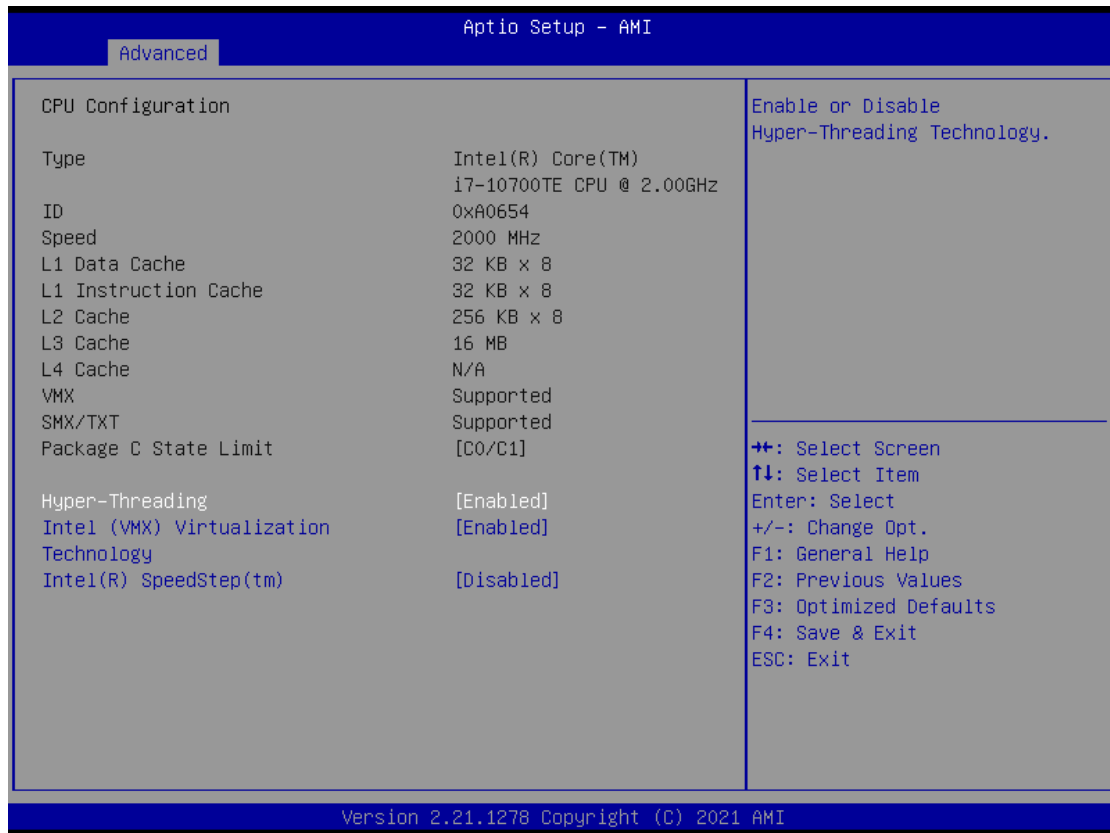

- **Hyper Threading**

To select Hyper-threading function which is Intel's proprietary simultaneous multithreading (SMT) implementation used to improve parallelization of computations (doing multiple tasks at once) performed on x86 microprocessors.

- **Intel Virtualization Technology**

Allows a hardware platform to run multiple operating systems separately and simultaneously, enabling one system to virtually function as several systems.

- **Storage Configuration**

You can use this screen to select options for the Storage Configuration, and change the value of the selected option. A description of the selected item appears on the right side of the screen.

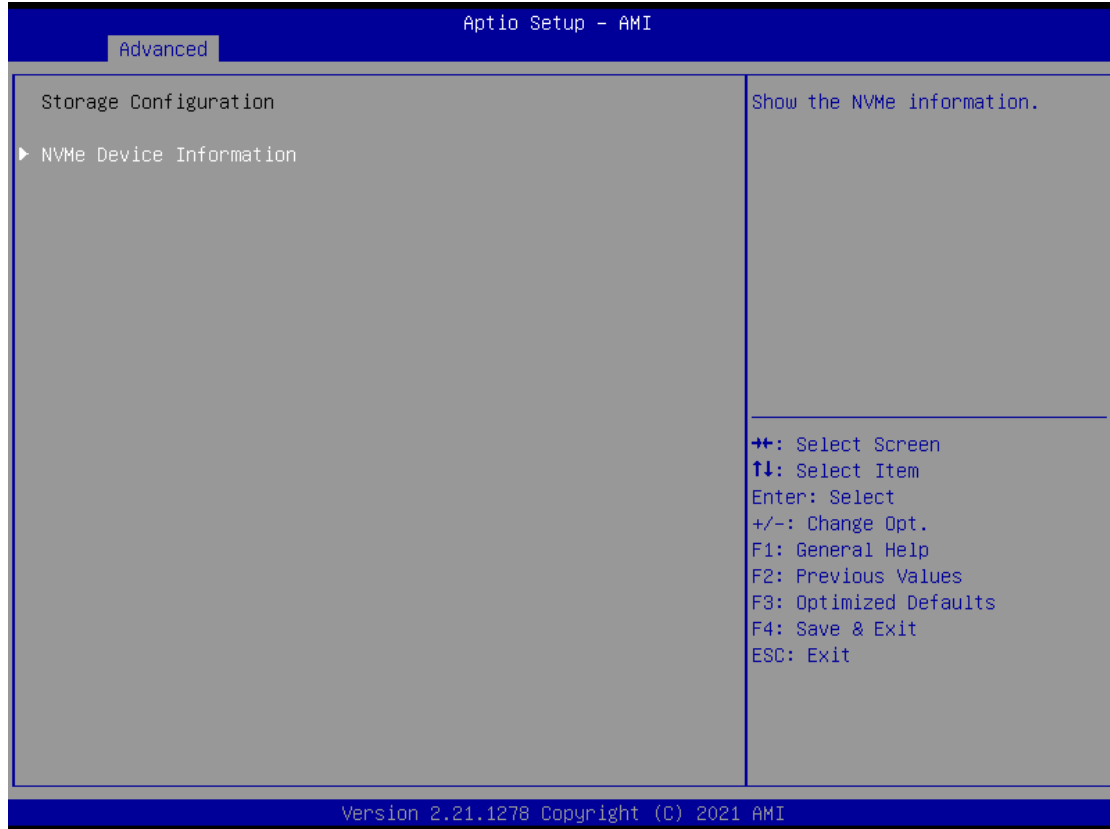

- **NVMe Device Information**

Display the information of NVMe storage.

- **USB Configuration**

You can use this screen to confirm USB settings.

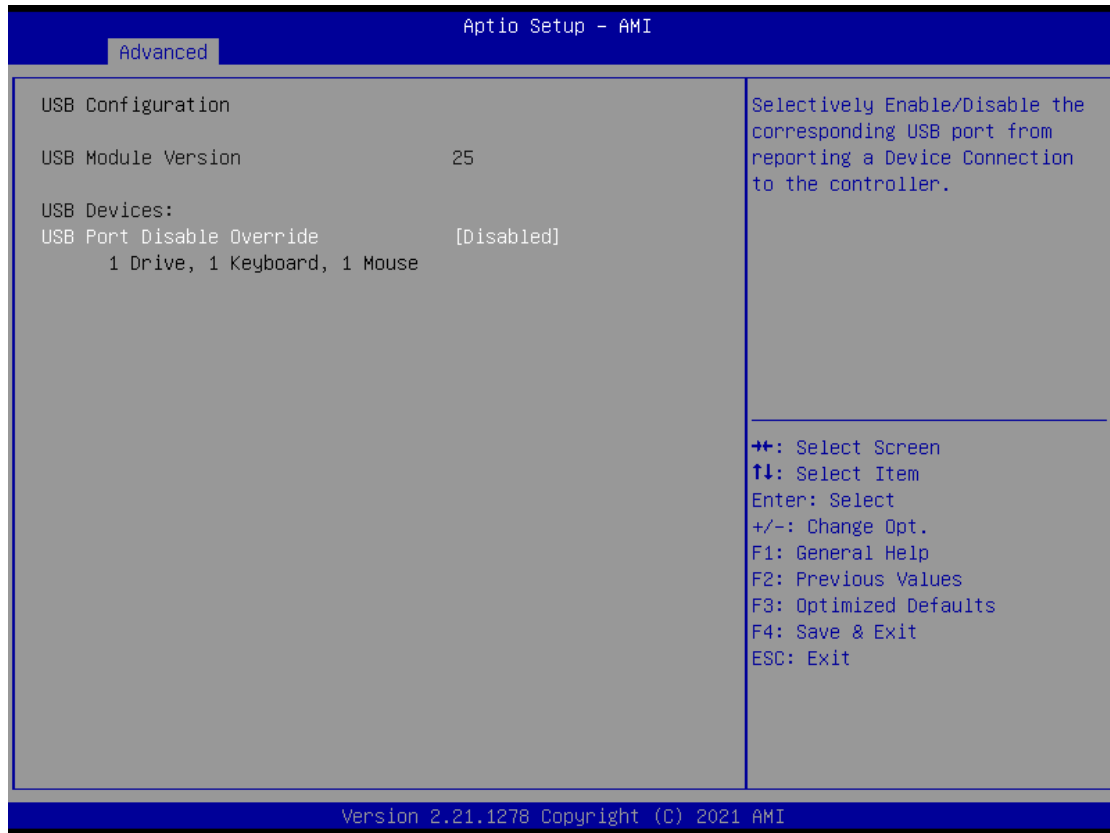

- **CSM Configuration**

Configure settings associated with the CSM (Compatibility Support Module), such as Option ROM execution.

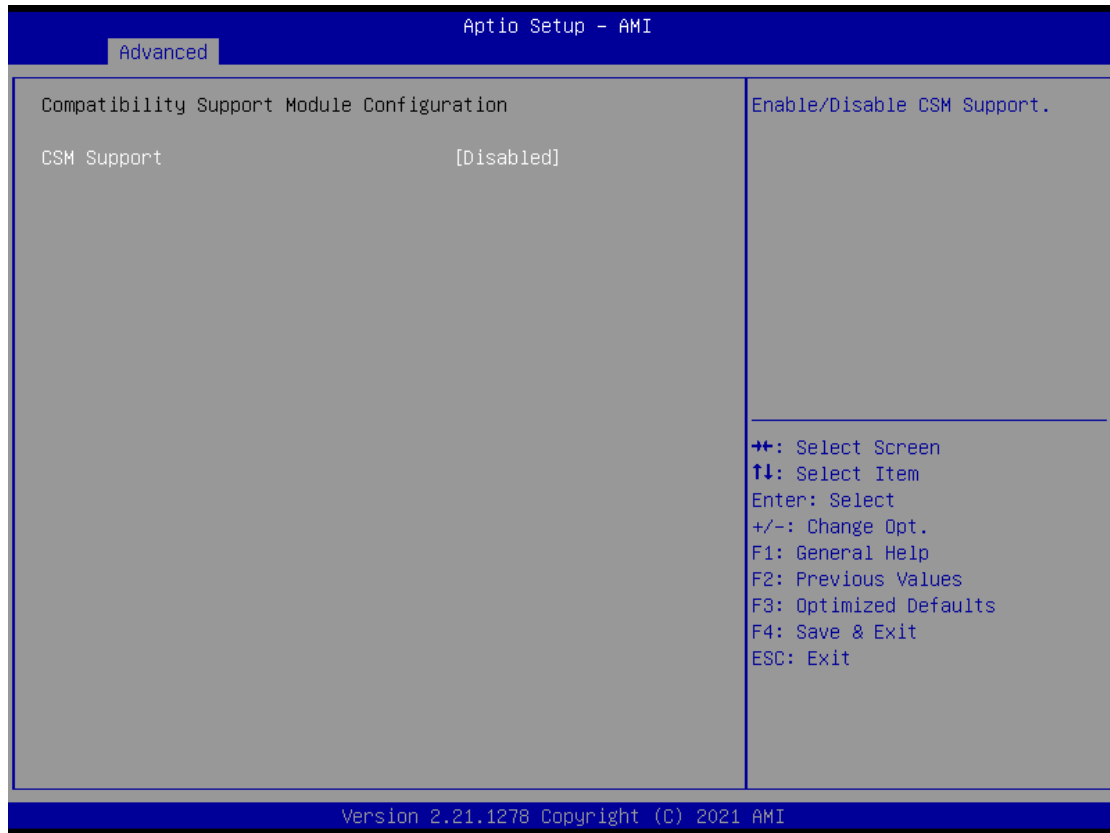

4.5 Chipset Menu

The Chipset menu allows users to change the advanced chipset settings. You can select any of the items in the left frame of the screen to go to the sub menus:

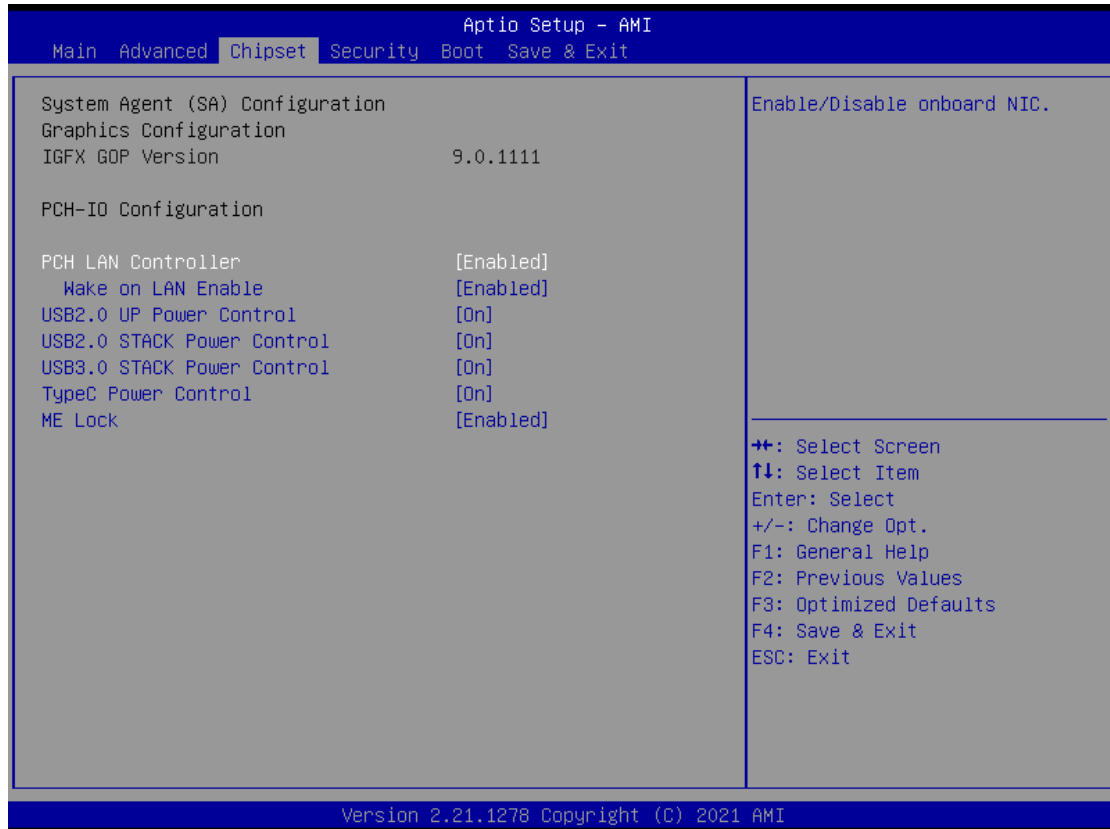

- **PCH LAN Controller**
Enable or disable PCH LAN controller.
- **Wake on LAN**
Enable or disable Wake on LAN functionality.
- **USB 2.0 UP Power Control**
Enable or disable USB 2.0 port power.
- **USB 2.0 Stack Power Control**
Enable or disable USB 2.0 Stack port power.
- **USB 3.0 Stack Power Control**
Enable or disable USB 3.0 Stack port power.
- **TypeC Power Control**
Enable or disable USB Type-C port power.
- **ME Lock**
Enable or disable ME lock.

4.6 Boot Menu

The Boot menu allows users to change boot options of the system. You can select any of the items in the left frame of the screen to go to the sub menus:

- **Setup Prompt Timeout**
- **Boot up NumLock State**
- **Quiet Boot**
- **Boot Option Priorities**

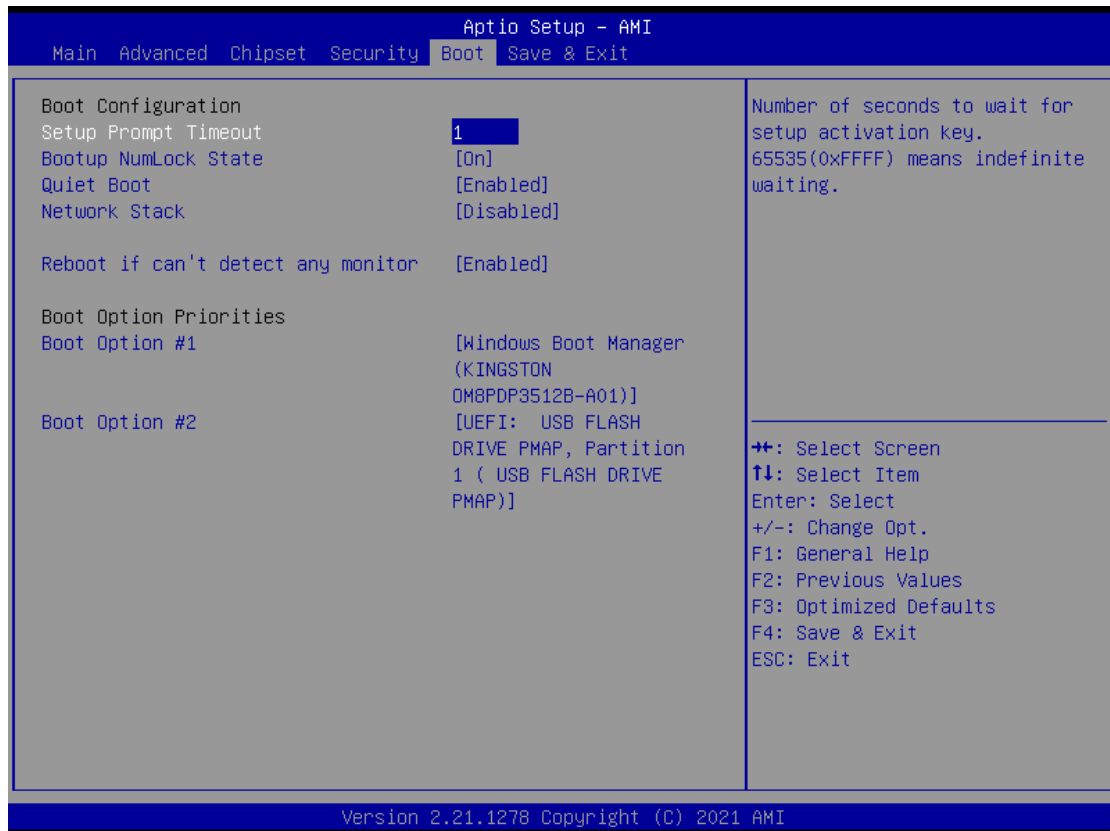

- **Setup Prompt Timeout**
Set the number of seconds to wait for Setup activation key.
- **Boot up NumLock State**
Use this item to select the power-on state for the Mum Lock. The default setting is on.
- **Quiet Boot**
Use this item to enable or disable the Quite Boot state. The default setting is disable.
- **Boot Option Priorities**
Sets the system boot order

4.7 Security Menu

The Security menu allows users to change the security settings for the system.

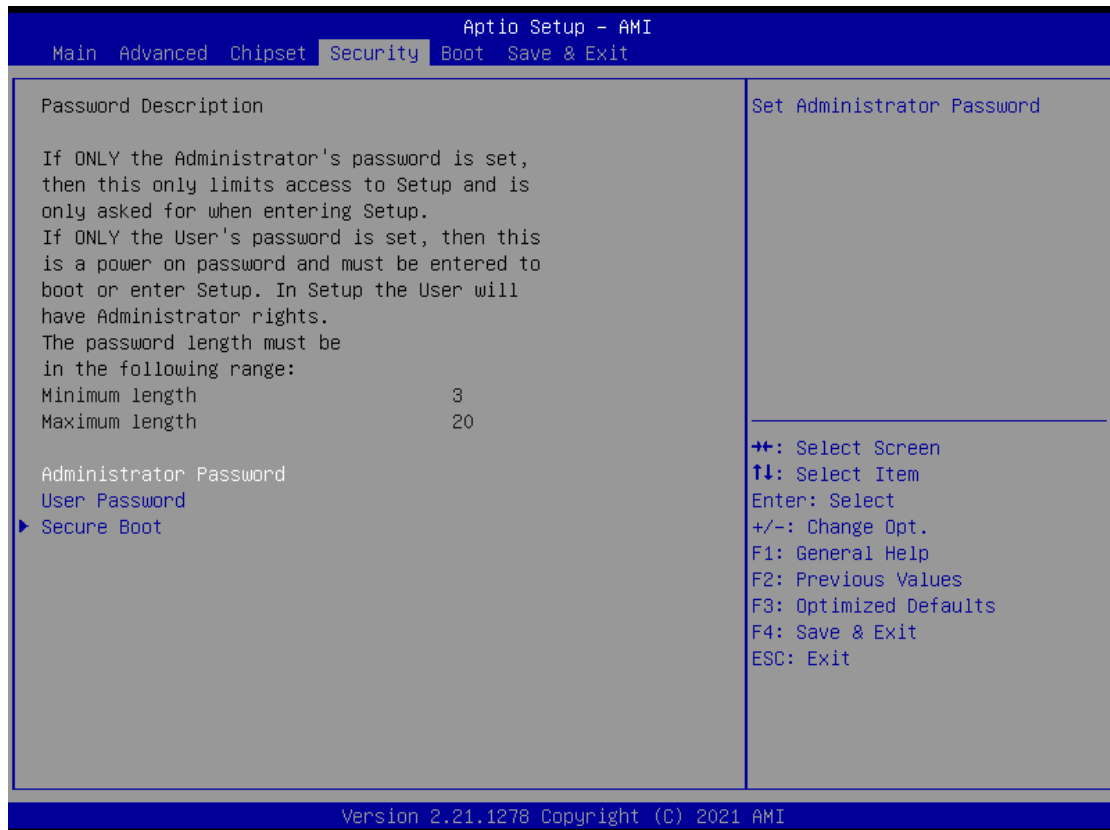

➤ Administrator Password

This item indicates whether an administrator password has been set. If the Administrator password is set, BIOS will ask and wait for administrator password entered.

➤ User Password

This item indicates whether a user password has been set. If the password is set, BIOS will ask and wait for User password entered

4.8 Save & Exit Menu

The Save & Exit menu allows users to load your system configuration with optimal or failsafe default values.

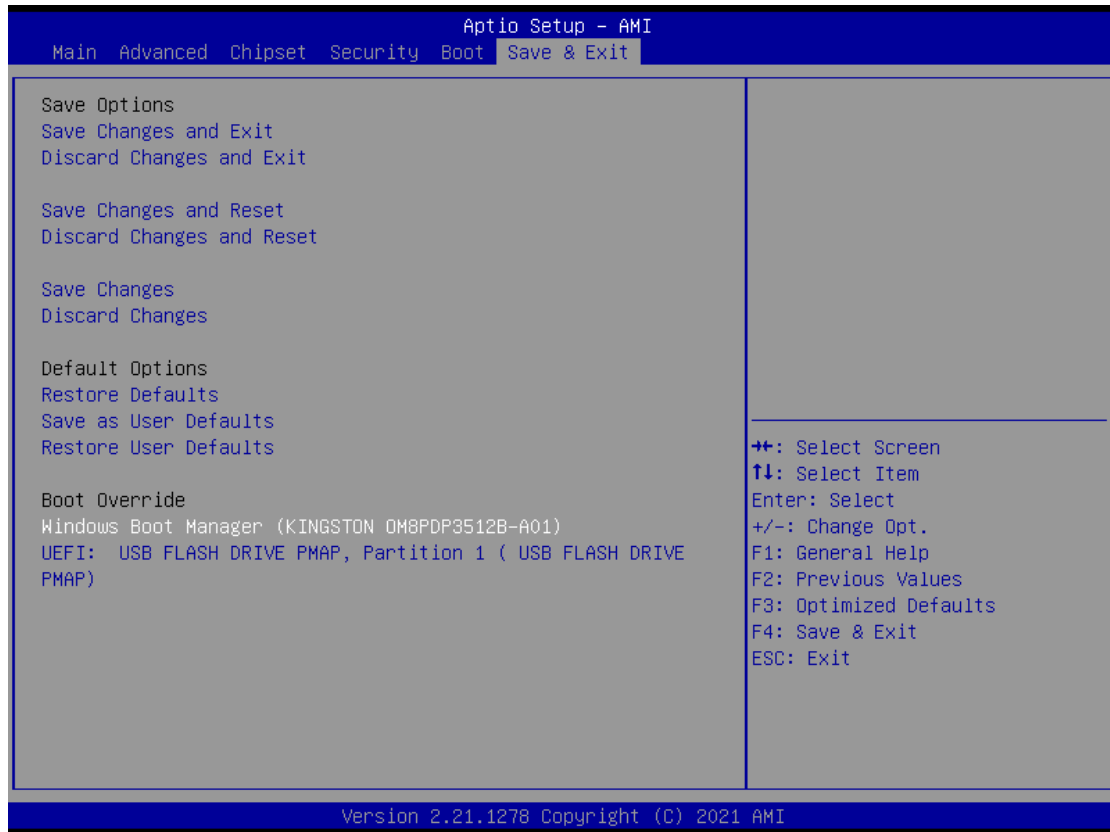

➤ Save Changes and Exit

When you have completed the system configuration changes, select Save Changes and Exit from the Save & Exit menu and press <Enter>. Select Yes to save changes and exit BIOS Setup.

➤ Discard Changes and Exit

This option provide quit Setup without making any permanent changes to the system configuration. Select Discard Changes and Exit from the Save & Exit menu and press <Enter>. Select Yes to discard changes and exit BIOS Setup.

➤ Save Changes and Reset

When you have completed the system configuration changes, select this option to leave Setup and reboot the computer so the new system configuration parameters can take effect. Select Save Changes and Reset from the Save & Exit menu and press <Enter>. Select Yes to save changes and reset.

➤ **Discard Changes and Reset**

Select this option to quit Setup without making any permanent changes to the system configuration and reboot the computer. Select Discard Changes and Reset from the Save & Exit menu and press <Enter>. Select Yes to discard changes and reset.

➤ **Save Changes**

When you have completed the system configuration changes, select this option to save changes. Select Save Changes from the Save & Exit menu and press <Enter>. Select Yes to save changes.

➤ **Discard Changes**

Select this option to quit Setup without making any permanent changes to the system configuration. Select Discard Changes from the Save & Exit menu and press <Enter>. Select Yes to discard changes.

➤ **Restore Defaults**

It automatically sets all Setup options to a complete set of default settings when you select this option. The Optimal settings are designed for maximum system performance, but may not work best for all computer applications. In particular, do not use the Optimal Setup options if your computer is experiencing system configuration problems. Select Restore Defaults from the save & Exit menu and press <Enter>.

➤ **Save as User Defaults**

Select this option to save system configuration changes done so far as User Defaults. Select Save as User Defaults from the Save & Exit menu and press <Enter>.

➤ **Restore User Defaults**

It automatically sets all Setup options to a complete set of User Defaults when you select this option. Select Restore User Defaults from the Save & Exit menu and press <Enter>.

This page is intentionally left blank.

APPENDIX A WATCHDOG TIMER

Watchdog Timer Setting

After the system stops working for a while, it can be auto-reset by the Watchdog Timer. The integrated Watchdog Timer can be set up in the system reset mode by program.

Using the Watchdog Function Start

1. Enable configuration (Following is example to enable configuration by using debug)

-O 2E 87

-O 2E 87

2. Select Logic device:

-O 2E 07

-O 2F 08

3. WDT Device Enable

-O 2E 30

-O 2F 01

4. Set timer unit

-O 2E F0

-O 2F 00 (0: Sec ; 8: Minute)

5. Set base timer:

-O 2E F1

-O 2F 0A → Set Reset Time (Ex. A: 10 Sec)

6. Disable WDT

-O 2E 30

-O 2F 00

This page is intentionally left blank.