

# Quectel EG25-G Mini PCIe

IoT/M2M-optimized  
LTE Cat 4 Module



Quectel EG25-G Mini PCIe is an LTE category 4 module adopting standard PCI Express® Mini Card form factor (Mini PCIe). It is optimized specially for M2M and IoT applications, and delivers maximum data rates up to 150Mbps downlink and 50Mbps uplink.

EG25-G Mini PCIe is backward-compatible with existing EDGE and GSM/GPRS networks, ensuring that it can be connected even in remote areas devoid of 4G or 3G coverage.

EG25-G Mini PCIe supports Qualcomm® IZat™ location technology Gen8C Lite (GPS, GLONASS, BeiDou/Compass, Galileo and QZSS). The integrated GNSS greatly simplifies product design, and provides quicker, more accurate and dependable positioning.

A rich set of Internet protocols, industry-standard interfaces and abundant functionalities (USB serial drivers for Windows 7/8/8.1/10, Linux, Android/eCall\*) extend the applicability of the module to a wide range of M2M applications such as industrial router, industrial PDA, rugged tablet PC, video surveillance and digital signage, etc.



## Key Benefits

- ✓ LTE category 4 module optimized for broadband IoT applications
- ✓ Worldwide LTE, UMTS/HSPA+ and GSM/GPRS/EDGE coverage
- ✓ Standard PCI Express® Mini Card form factor (Mini PCIe) ideal for manufacturers to easily integrate wireless connectivity into their devices
- ✓ MIMO technology meets demands for data rate and link reliability in modem wireless communication systems
- ✓ Multi-constellation GNSS receiver available for applications requiring fast and accurate fixes in any environment



LTE Cat 4  
Max 150Mbps (DL)  
Max 50Mbps (UL)



Max 42Mbps (DL)  
Max 5.76Mbps (UL)



Mini PCIe Package



Embedded Abundant Protocols



eCall\*



Multi-constellation GNSS



USB 2.0 High Speed Interface



USB Drivers



Quectel Enhanced AT Commands

# Quectel

## EG25-G Mini PCIe

### IoT/M2M-optimized LTE Cat 4 Module

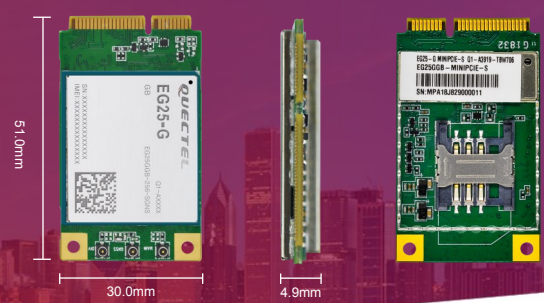

#### Frequency Bands

##### EG25-G Mini PCIe:

LTE-FDD: B1/B2/B3/B4/B5/B7/B8/B12/B13/B18/  
B19/B20/B25/B26/B28

LTE-TDD: B38/B39/B40/B41

WCDMA: B1/B2/B4/B5/B6/B8/B19

GSM: B2/B3/B5/B8

#### Data

##### LTE:

LTE-FDD: Max 150Mbps (DL)/Max 50Mbps (UL)

LTE-TDD: Max 130Mbps (DL)/Max 30Mbps (UL)

##### UMTS:

DC-HSDPA: Max 42Mbps (DL)

HSUPA: Max 5.76Mbps (UL)

WCDMA: Max 384Kbps (DL)/Max 384Kbps (UL)

##### GSM:

EDGE: Max 296Kbps (DL)/Max 236.8Kbps (UL)

GPRS: Max 107Kbps (DL)/Max 85.6Kbps (UL)

#### Voice

##### Speech Codec Modes:

HR/FR/EFR/AMR/AMR-WB

##### Echo Arithmetic:

Echo Cancellation/Noise Suppression

##### Audio:

Digital Audio and VoLTE (Voice over LTE)

(Optional)

#### Interfaces

USB x 1: USB 2.0 with High Speed up to 480Mbps

PCM x 1: Digital Audio through PCM (Optional)

I2C x 1

(U)SIM x 1: 1.8V/3.0V (U)SIM Interface

UART x 1: Main UART

LED\_WWAN# for Network Status Indication

W\_DISABLE# for Disabling RF Function

PERST# for Module Resetting

Main, Rx-diversity and GNSS Antenna Connectors

#### Enhanced Features

eCall\*

DTMF

Audio Playback/Audio Recording

(U)SIM Card Detection

QuecFile\*

(U)SIM Card Connector (Optional) ①

QuecLocator®

Downlink MIMO (Supports Rx-diversity Antenna)

##### DFOTA:

Delta Firmware Upgrade Over-The-Air

##### GNSS:

GPS/GLONASS/BeiDou (Compass)/Galileo/QZSS

(Optional)

#### Electrical Characteristics

##### Output Power:

Class 3 (23dBm±2dB) for LTE-FDD bands

Class 3 (23dBm±2dB) for LTE-TDD bands

Class 3 (24dBm+1/-3dB) for WCDMA bands

Class E2 (27dBm±3dB) for GSM850 8-PSK

Class E2 (27dBm±3dB) for EGSM900 8-PSK

Class E2 (26dBm±3dB) for DCS1800 8-PSK

Class E2 (26dBm±3dB) for PCS1900 8-PSK

Class 4 (33dBm±2dB) for GSM850

Class 4 (33dBm±2dB) for EGSM900

Class 1 (30dBm±2dB) for DCS1800

Class 1 (30dBm±2dB) for PCS1900

##### Consumption:

3.6mA @Sleep, Typ.

35mA @Idle

##### Sensitivity:

LTE B1: -99.5 (10MHz)

LTE B2: -99.9dBm (10MHz)

LTE B3: -99.7dBm (10MHz)

LTE B4: -99.7dBm (10MHz)

LTE B5: -99.9dBm (10MHz)

LTE B7: -99.2dBm (10MHz)

LTE B8: -99.8dBm (10MHz)

LTE B12: -99.8dBm (10MHz)

LTE B13: -99.5dBm (10MHz)

LTE B18: -100dBm (10MHz)

LTE B19: -99.9dBm (10MHz)

LTE B20: -99.8dBm (10MHz)

LTE B25: -100dBm (10MHz)

LTE B26: -99.5dBm (10MHz)

LTE B28: -99.6dBm (10MHz)

LTE B38: -99dBm (10MHz)

LTE B39: -99.5dBm (10MHz)

LTE B40: -99.2dBm (10MHz)

LTE B41: -99dBm (10MHz)

WCDMA B1: -109.2dBm

WCDMA B2: -110dBm

WCDMA B4: -109.7dBm

WCDMA B5: -110.4dBm

WCDMA B6: -110.5dBm

WCDMA B8: -110.5dBm

WCDMA B19: -110.1dBm

GSM850: -108dBm

EGSM900: -108dBm

DCS: -107.5dBm

PCS: -107.5dBm

#### Software Features

##### USB Serial Driver:

Windows 7/8/8.1/10,

Linux 2.6~5.4,

Android 4.x/5.x/6.x/7.x/9.x

##### GNSS Driver:

Android 4.x/5.x/6.x/7.x/8.x/9.x

##### RIL Driver:

Android 4.x/5.x/6.x/7.x/8.x/9.x

#### NDIS Driver:

Windows 7/8/8.1/10

#### MBIM Driver:

Windows 8/8.1/10, Linux 3.18~5.4

#### GobiNet Driver:

Linux 2.6~5.4

#### QMI\_WWAN Driver:

Linux 2.6~5.4

#### Protocols:

TCP/UDP/PPP/FTP/HTTP/NTP/PING/QMI/NITZ/  
SMTP/MQTT/CMUX/HTTPS/FTPS/SMTPTS/SSL/  
MMS\*/FILE\*

#### General Features

Operation Temperature Range: -35°C ~ +75°C

Extended Temperature Range: -40°C ~ +80°C

Dimensions: 51.0mm x 30.0mm x 4.9mm

Weight: Approx. 9.8g

Mini PCIe Package

Supply Voltage: 3.0V~3.6V, 3.3V Typ.

3GPP E-UTRA Release 11

Bandwidth: 1.4/3/5/10/15/20MHz

3GPP TS27.007 and Enhanced AT Commands

#### Approvals

##### Carrier:

Deutsche Telekom (Europe)

Verizon/AT&T/U.S. Cellular/T-Mobile\*/Sprint\*

(North America)

Telus/Rogers\* (Canada)

##### Regulatory:

GCF (Global)

CE (Europe)

FCC/PTCRB (North America)

IC (Canada)

Anatel (Brazil)

IFETEL (Mexico)

SRRC/CCC/NAL (China)

KC (South Korea)

NCC (Taiwan, China)

JATE/TELEC (Japan)

RCM (Australia & New Zealand)

FAC\* (Russia)

NBTC\* (Thailand)

IMDA (Singapore)

ICASA (South Africa)

##### Others:

RoHS

WHQL

\* Under Development

① There are two types of EG25-G Mini PCIe,

with or without (U)SIM card connector.

# EG25-G Mini PCIe

# Hardware Design

**LTE Standard Module Series**

Rev. EG25-G\_Mini\_PcIe\_Hardware\_Design\_V1.2

Date: 2020-04-29

Status: Released



**Our aim is to provide customers with timely and comprehensive service. For any assistance, please contact our company headquarters:**

**Quectel Wireless Solutions Co., Ltd.**

Building 5, Shanghai Business Park Phase III (Area B), No.1016 Tianlin Road, Minhang District, Shanghai, China 200233

Tel: +86 21 5108 6236

Email: [info@quectel.com](mailto:info@quectel.com)

**Or our local office. For more information, please visit:**

<http://www.quectel.com/support/sales.htm>

**For technical support, or to report documentation errors, please visit:**

<http://www.quectel.com/support/technical.htm>

Or email to: [support@quectel.com](mailto:support@quectel.com)

**GENERAL NOTES**

QUECTEL OFFERS THE INFORMATION AS A SERVICE TO ITS CUSTOMERS. THE INFORMATION PROVIDED IS BASED UPON CUSTOMERS' REQUIREMENTS. QUECTEL MAKES EVERY EFFORT TO ENSURE THE QUALITY OF THE INFORMATION IT MAKES AVAILABLE. QUECTEL DOES NOT MAKE ANY WARRANTY AS TO THE INFORMATION CONTAINED HEREIN, AND DOES NOT ACCEPT ANY LIABILITY FOR ANY INJURY, LOSS OR DAMAGE OF ANY KIND INCURRED BY USE OF OR RELIANCE UPON THE INFORMATION. ALL INFORMATION SUPPLIED HEREIN IS SUBJECT TO CHANGE WITHOUT PRIOR NOTICE.

**COPYRIGHT**

THE INFORMATION CONTAINED HERE IS PROPRIETARY TECHNICAL INFORMATION OF QUECTEL WIRELESS SOLUTIONS CO., LTD. TRANSMITTING, REPRODUCTION, DISSEMINATION AND EDITING OF THIS DOCUMENT AS WELL AS UTILIZATION OF THE CONTENT ARE FORBIDDEN WITHOUT PERMISSION. OFFENDERS WILL BE HELD LIABLE FOR PAYMENT OF DAMAGES. ALL RIGHTS ARE RESERVED IN THE EVENT OF A PATENT GRANT OR REGISTRATION OF A UTILITY MODEL OR DESIGN.

***Copyright © Quectel Wireless Solutions Co., Ltd. 2020. All rights reserved.***

# About the Document

## Revision History

Version	Date	Author	Description
1.0	2019-11-21	Lorry XU/ Ethan SHAN	Initial
1.1	2020-04-29	Ward WANG/ Ethan SHAN	<ol style="list-style-type: none"><li>1. Reserved COEX UART Interface.</li><li>2. Updated supported protocols (Table 2).</li><li>3. Added operating modes of the module (Chapter 3.1).</li><li>4. Added description of power saving (Chapter 3.2).</li><li>5. Updated description of power supply (Chapter 3.3).</li><li>6. Added a note about the (U)SIM card connector of (U)SIM interface (Chapter 3.4).</li><li>7. Updated the description of W_DISABLE# signal (Chapter 3.8.3) and PERST# signal (Chapter 3.8.4).</li><li>8. Updated the description of recommended mating plugs for antenna connection (Chapter 5.3).</li><li>9. Updated note 2 (Chapter 6.4).</li><li>10. Updated current consumption of the module (Table 24).</li><li>11. Added the note about the standard that the package warpage level of the module conforms to (Chapter 7.1).</li><li>12. Updated the Mini PCI Express connector type (Figure 21).</li><li>13. Deleted eCall and voice over USB functions.</li></ol>

## Contents

About the Document .....	2
Contents .....	3
Table Index .....	5
Figure Index .....	6
<b>1 Introduction .....</b>	<b>7</b>
1.1. Safety Information .....	8
<b>2 Product Concept .....</b>	<b>9</b>
2.1. General Description .....	9
2.2. Module Description .....	9
2.3. Key Features .....	10
2.4. Functional Diagram .....	13
<b>3 Application Interfaces .....</b>	<b>14</b>
3.1. Pin Assignment .....	14
3.2. Pin Description .....	15
3.1. Operating Modes .....	18
3.2. Power Saving .....	19
3.2.1. Sleep Mode .....	19
3.2.2. Airplane Mode .....	19
3.3. Power Supply .....	19
3.4. (U)SIM Interface .....	20
3.5. USB Interface .....	22
3.6. UART Interface .....	23
3.7. PCM and I2C Interfaces .....	24
3.8. Control and Indication Signals .....	27
3.8.1. RI Signal .....	27
3.8.2. DTR Signal .....	27
3.8.3. W_DISABLE# Signal .....	28
3.8.4. PERST# Signal .....	28
3.8.5. LED_WWAN# Signal .....	29
3.8.6. WAKE# Signal .....	30
<b>4 GNSS Receiver .....</b>	<b>31</b>
4.1. General Description .....	31
4.2. GNSS Performance .....	31
4.3. GNSS Frequency .....	32
<b>5 Antenna Connection .....</b>	<b>33</b>
5.1. Antenna Connectors .....	33
5.1.1. Operating Frequency .....	33
5.2. Antenna Requirements .....	35
5.3. Recommended Mating Plugs for Antenna Connection .....	36

<b>6</b>	<b>Electrical, Reliability and Radio Characteristics .....</b>	<b>38</b>
6.1.	General Description .....	38
6.2.	Power Supply Requirements .....	38
6.3.	I/O Requirements.....	39
6.4.	RF Characteristics .....	39
6.5.	ESD Characteristics .....	42
6.6.	Current Consumption .....	42
6.7.	Thermal Consideration .....	47
<b>7</b>	<b>Dimensions and Packaging .....</b>	<b>49</b>
7.1.	General Description .....	49
7.2.	Mechanical Dimensions of EG25-G Mini PCIe .....	49
7.3.	Standard Dimensions of Mini PCI Express .....	50
7.4.	Packaging Specifications.....	51
<b>8</b>	<b>Appendix A References.....</b>	<b>52</b>

## Table Index

Table 1: Description of EG25-G Mini PCIe .....	9
Table 2: Key Features of EG25-G Mini PCIe .....	10
Table 3: I/O Parameters Definition .....	15
Table 4: Pin Description .....	15
Table 5: Overview of Operating Modes.....	18
Table 6: Definition of VCC_3V3 and GND Pins .....	19
Table 7: Pin Definition of (U)SIM Interface.....	20
Table 8: Pin Definition of USB Interface.....	22
Table 9: Pin Definition of Main UART Interface.....	24
Table 10: Pin Definition of PCM and I2C Interfaces .....	25
Table 11: Pin Definition of Control and Indication Signals .....	27
Table 12: Airplane Mode Controlled by Hardware Method .....	28
Table 13: Airplane Mode Controlled by Software Method.....	28
Table 14: Indications of Network Status (AT+QCFG="ledmode",0, Default Setting).....	30
Table 15: Indications of Network Status (AT+QCFG="ledmode",2).....	30
Table 16: GNSS Frequency .....	32
Table 17: Operating Frequencies .....	33
Table 18: Antenna Requirements .....	35
Table 19: Power Supply Requirements .....	38
Table 20: I/O Requirements .....	39
Table 21: EG25-G Mini PCIe Conducted RF Output Power .....	39
Table 22: EG25-G Mini PCIe Conducted RF Receiving Sensitivity .....	40
Table 23: ESD Characteristics of EG25-G Mini PCIe .....	42
Table 24: Current Consumption of EG25-G Mini PCIe .....	42
Table 25: GNSS Current Consumption of EG25-G Mini PCIe.....	47
Table 26: Related Documents .....	52
Table 27: Terms and Abbreviations .....	52



## Figure Index

Figure 1: Functional Diagram.....	13
Figure 2: Pin Assignment .....	14
Figure 3: Reference Circuit of Power Supply.....	20
Figure 4: Reference Circuit of (U)SIM Interface with an 8-pin (U)SIM Card Connector .....	21
Figure 5: Reference Circuit of (U)SIM Interface with a 6-pin (U)SIM Card Connector .....	21
Figure 6: Reference Circuit of USB Interface .....	23
Figure 7: Reference Circuit of Power Supply.....	24
Figure 8: Timing in Primary Mode .....	25
Figure 9: Timing in Auxiliary Mode .....	26
Figure 10: Reference Circuit of PCM and I2C Application with Audio Codec .....	26
Figure 11: RI Behaviors.....	27
Figure 12: Timing of Resetting Module .....	29
Figure 13: LED_WWAN# Signal Reference Circuit Diagram .....	29
Figure 14: WAKE# Behaviors .....	30
Figure 15: Dimensions of the Receptacle RF Connectors (Unit: mm) .....	36
Figure 16: Mechanicals of U.FL-LP Mating Plugs .....	36
Figure 17: Space Factor of Mating Plugs (Unit: mm).....	37
Figure 18: Reference Heatsink Design .....	48
Figure 19: Mechanical Dimensions of EG25-G Mini PCIe.....	49
Figure 20: Standard Dimensions of Mini PCI Express.....	50
Figure 21: Dimensions of the Mini PCI Express Connector (Molex 679105700).....	51

# 1 Introduction

This document defines EG25-G Mini PCIe module, and describes its air interfaces and hardware interfaces which are connected with customers' applications.

This document helps customers quickly understand module interface specifications, electrical characteristics, mechanical specifications and other related information of the module. To facilitate application designs, it also includes some reference designs for customers' reference. The document, coupled with application notes and user guides, makes it easy to design and set up wireless applications with EG25-G Mini PCIe.

## 1.1. Safety Information

The following safety precautions must be observed during all phases of operation, such as usage, service or repair of any cellular terminal or mobile incorporating EG25-G Mini PCIe module. Manufacturers of the cellular terminal should send the following safety information to users and operating personnel, and incorporate these guidelines into all manuals supplied with the product. If not so, Quectel assumes no liability for customers' failure to comply with these precautions.



Full attention must be given to driving at all times in order to reduce the risk of an accident. Using a mobile while driving (even with a handsfree kit) causes distraction and can lead to an accident. Please comply with laws and regulations restricting the use of wireless devices while driving.



Switch off the cellular terminal or mobile before boarding an aircraft. The operation of wireless appliances in an aircraft is forbidden to prevent interference with communication systems. If the device offers an Airplane Mode, then it should be enabled prior to boarding an aircraft. Please consult the airline staff for more restrictions on the use of wireless devices on boarding the aircraft.



Wireless devices may cause interference on sensitive medical equipment, so please be aware of the restrictions on the use of wireless devices when in hospitals, clinics or other healthcare facilities.



The cellular terminal or mobile contains a transmitter and receiver. When it is ON, it receives and transmits radio frequency signals. RF interference can occur if it is used close to TV set, radio, computer or other electric equipment.



In locations with potentially explosive atmospheres, obey all posted signs to turn off wireless devices such as your phone or other cellular terminals. Areas with potentially explosive atmospheres include fuelling areas, below decks on boats, fuel or chemical transfer or storage facilities, areas where the air contains chemicals or particles such as grain, dust or metal powders, etc.

# 2 Product Concept

## 2.1. General Description

EG25-G Mini PCIe module provides data connectivity on LTE-FDD, LTE-TDD, DC-HSDPA, HSPA+, HSDPA, HSUPA, WCDMA, EDGE and GPRS networks with PCI Express Mini Card 1.2 standard interface. It supports embedded operating systems such as Linux, Android, etc., and also provides audio, high-speed data transmission and GNSS functionalities for customers' applications.

EG25-G Mini PCIe module can be applied in the following fields:

- PDA and Laptop Computer
- Remote Monitor System
- Vehicle System
- Wireless POS System
- Intelligent Meter Reading System
- Wireless Router and Switch
- Other Wireless Terminal Devices

## 2.2. Module Description

The following table shows the supported frequency bands, GNSS and digital audio functions of EG25-G Mini PCIe module.

**Table 1: Description of EG25-G Mini PCIe**

Frequency Bands/ GNSS/ Digital Audio	EG25-G Mini PCIe
LTE-FDD	B1/B2/B3/B4/B5/B7/B8/B12/B13/B18/B19/B20/B25/B26/B28
LTE-TDD	B38/B39/B40/B41
WCDMA	B1/B2/B4/B5/B6/B8/B19

GSM	850/900/1800/1900 MHz
GNSS (Optional)	GPS, GLONASS, BeiDou (Compass), Galileo, QZSS
Digital Audio (PCM)	Supported

## 2.3. Key Features

The following table describes the detailed features of EG25-G Mini PCIe module.

**Table 2: Key Features of EG25-G Mini PCIe**

Features	Description
Function Interface	PCI Express Mini Card 1.2 Standard Interface
Power Supply	Supply voltage: 3.0–3.6 V Typical supply voltage: 3.3 V
Transmitting Power	Class 4 (33 dBm $\pm$ 2 dB) for GSM850 Class 4 (33 dBm $\pm$ 2 dB) for EGSM900 Class 1 (30 dBm $\pm$ 2 dB) for DCS1800 Class 1 (30 dBm $\pm$ 2 dB) for PCS1900 Class E2 (27 dBm $\pm$ 3 dB) for GSM850 8-PSK Class E2 (27 dBm $\pm$ 3 dB) for EGSM900 8-PSK Class E2 (26 dBm $\pm$ 3 dB) for DCS1800 8-PSK Class E2 (26 dBm $\pm$ 3 dB) for PCS1900 8-PSK Class 3 (24 dBm +1/-3 dB) for WCDMA bands Class 3 (23 dBm $\pm$ 2 dB) for LTE-FDD bands Class 3 (23 dBm $\pm$ 2 dB) for LTE-TDD bands
LTE Features	Support up to non-CA Cat 4 FDD and TDD Support 1.4/3/5/10/15/20 MHz RF bandwidth Support MIMO in DL direction LTE-FDD: Max 150 Mbps (DL), Max 50 Mbps (UL) LTE-TDD: Max 130 Mbps (DL), Max 30 Mbps (UL)
UMTS Features	Support 3GPP R8 DC-HSDPA, HSPA+, HSDPA, HSUPA and WCDMA Support QPSK, 16-QAM and 64-QAM modulation DC-HSDPA: Max 42 Mbps (DL) HSUPA: Max 5.76 Mbps (UL) WCDMA: Max 384 kbps (DL), Max 384 kbps (UL)
GSM Features	<b>GPRS:</b> Support GPRS multi-slot class 33 (33 by default) Coding scheme: CS-1, CS-2, CS-3 and CS-4

	<p>Max 107 kbps (DL), Max 85.6 kbps (UL)</p> <p><b>EDGE:</b> Support EDGE multi-slot class 33 (33 by default) Support GMSK and 8-PSK for different MCS (Modulation and Coding Scheme) Downlink coding schemes: CS 1-4 and MCS 1-9 Uplink coding schemes: CS 1-4 and MCS 1-9 Max 296 kbps (DL), Max 236.8 kbps (UL)</p>
Internet Protocol Features	<p>Support TCP/UDP/PPP/FTP/FTPS/HTTP/HTTPS/NTP/PING/QMI/NITZ/SMTTP/SSL/MQTT/CMUX/SMTTPS/FILE/LwM2M/MMS protocols</p> <p>Support PAP (Password Authentication Protocol) and CHAP (Challenge Handshake Authentication Protocol) protocols which are usually used for PPP connection</p>
SMS	<p>Text and PDU modes</p> <p>Point-to-point MO and MT</p> <p>SMS cell broadcast</p> <p>SMS storage: ME by default</p>
(U)SIM Interface	Support USIM/SIM card: 1.8 V, 3.0 V
UART Interface	<p>Main UART: Support RTS and CTS hardware flow control Baud rate can reach up to 230400 bps, 115200 bps by default Used for AT command communication and data transmission</p>
Audio Features	<p>Support one digital audio interface: PCM interface</p> <p>GSM: HR/FR/EFR/AMR/AMR-WB</p> <p>WCDMA: AMR/AMR-WB</p> <p>LTE: AMR/AMR-WB</p> <p>Support echo cancellation and noise suppression</p>
PCM Interface	<p>Support 16-bit linear data format</p> <p>Support long frame synchronization and short frame synchronization</p> <p>Support master and slave modes, but must be the master in long frame synchronization</p>
USB Interface	<p>Compliant with USB 2.0 specification (slave only); the data transfer rate can reach up to 480 Mbps</p> <p>Used for AT command communication, data transmission, firmware upgrade, software debugging and GNSS NMEA output.</p> <p>Support USB serial drivers for: Windows 7/8/8.1/10, Linux 2.6–5.4, Android 4.x–9.x, etc.</p>
Antenna Connectors	Include main antenna, diversity antenna and GNSS antenna receptacle connectors
Rx-diversity (Optional)	Support LTE/WCDMA Rx-diversity
GNSS Features	<p>Gen8C Lite of Qualcomm</p> <p>Protocol: NMEA 0183</p>

---

	Data update rate: 1 Hz by default
AT Commands	Compliant with 3GPP TS 27.007, 27.005 and Quectel enhanced AT commands
Physical Characteristics	Size: (51.0 ±0.15) mm × (30.0 ±0.15) mm × (4.9 ±0.2) mm Weight: approx. 9.8 g
Temperature Range	Operating temperature range: -35 to +75 °C <sup>1)</sup> Extended temperature range: -40 to +80 °C <sup>2)</sup> Storage temperature range: -40 to +90 °C
Firmware Upgrade	Upgrade via USB interface or DFOTA
RoHS	All hardware components are fully compliant with EU RoHS directive

---

**NOTES**

- 1) Within operating temperature range, the module is 3GPP compliant.
- 2) Within extended temperature range, the module remains the ability to establish and maintain a voice, SMS, data transmission, etc. There is no unrecoverable malfunction. There are also no effects on radio spectrum and no harm to radio network. Only one or more parameters like P<sub>out</sub> might reduce in their value and exceed the specified tolerances. When the temperature returns to normal operating temperature levels, the module will meet 3GPP specifications again.
3. "\*" means under development.

## 2.4. Functional Diagram

The following figure shows the block diagram of EG25-G Mini PCIe.

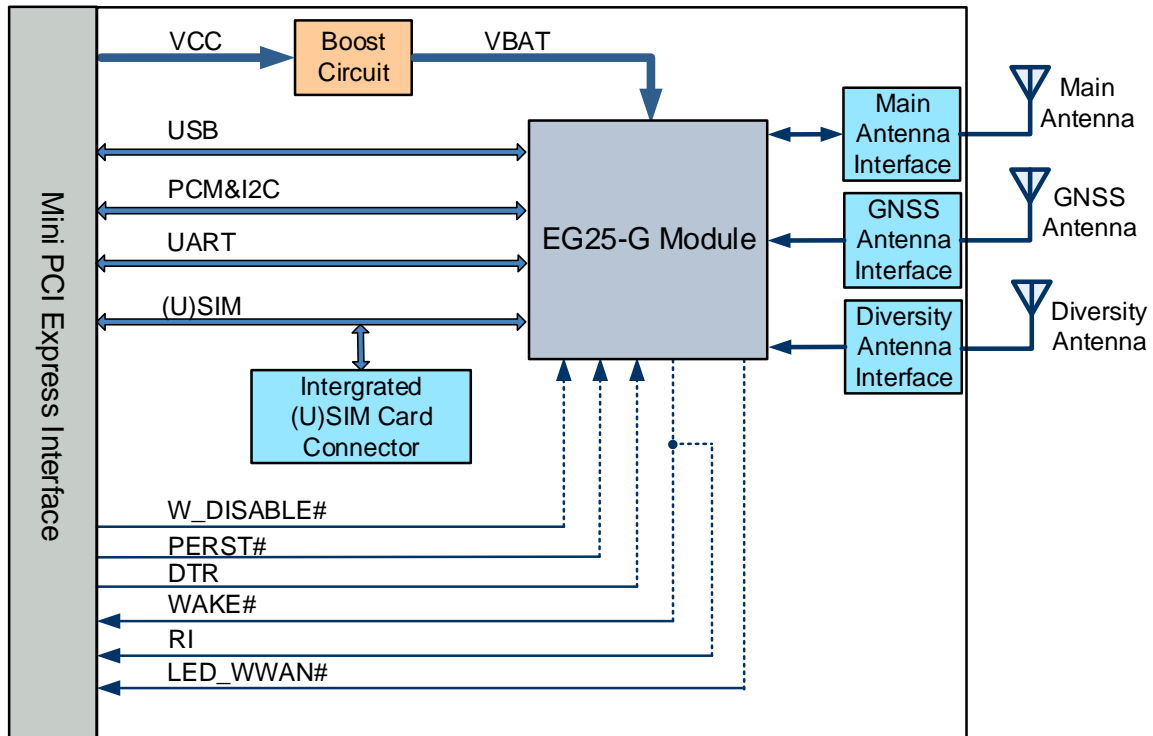

Figure 1: Functional Diagram

### NOTE

There are two types of EG25-G Mini PCIe, with or without integrated (U)SIM card connector, which is optional. The integrated (U)SIM card connector shares the same (U)SIM bus with the external (U)SIM card connector that connected to Mini PCI Express (U)SIM interface. It does not support (U)SIM card detection function, and cannot be used simultaneously with the external (U)SIM card connector. When unused, it has no any effect to the external (U)SIM card connector.



# 3 Application Interfaces

The physical connections and signal levels of EG25-G Mini PCIe comply with PCI Express Mini Card Electromechanical Specification. This chapter mainly describes the definition and application of the following interfaces/pins of EG25-G Mini PCIe:

- Power supply
- (U)SIM interface
- USB interface
- UART interface
- PCM and I2C interfaces
- Control and indication signals

## 3.1. Pin Assignment

The following figure shows the pin assignment of EG25-G Mini PCIe module. The top side contains EG25-G module and antenna connectors.

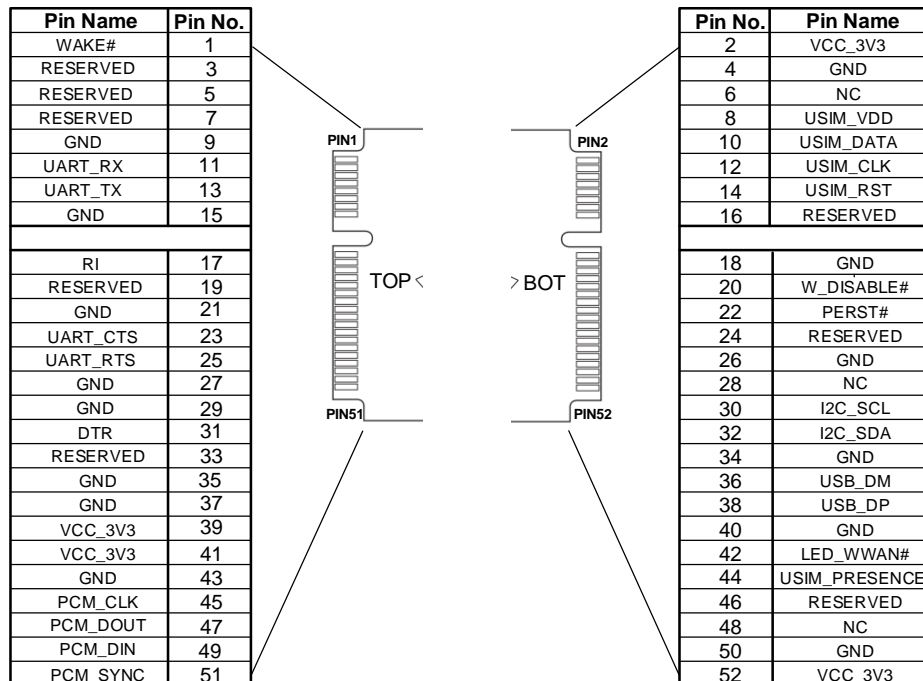

Figure 2: Pin Assignment

## 3.2. Pin Description

The following tables show the pin definition and description of the 52 pins on EG25-G Mini PCIe.

**Table 3: I/O Parameters Definition**

Type	Description
DI	Digital Input
DO	Digital Output
IO	Bidirectional
OC	Open Collector
PI	Power Input
PO	Power Output

**Table 4: Pin Description**

Pin No.	Mini PCI Express Standard Name	EG25-G Mini PCIe Pin Name	I/O	Description	Comment
1	WAKE#	WAKE#	OC	Output signal used to wake up the host.	
2	3.3Vaux	VCC_3V3	PI	3.0–3.6 V, typically 3.3 V DC supply	
3	COEX1	RESERVED		Reserved	It is prohibited to be pulled up high before startup.
4	GND	GND		Mini card ground	
5	COEX2	RESERVED		Reserved	It is prohibited to be pulled up high before startup.
6	1.5V	NC		Not connected	
7	CLKREQ#	RESERVED		Reserved	
8	UIM_PWR	USIM_VDD	PO	Power supply for the	

				(U)SIM card	
9	GND	GND		Mini card ground	
10	UIM_DATA	USIM_DATA	IO	Data signal of (U)SIM card	
11	REFCLK-	UART_RX	DI	UART receive data	Connect to DTE's TX.
12	UIM_CLK	USIM_CLK	DO	Clock signal of (U)SIM card	
13	REFCLK+	UART_TX	DO	UART transmit data	Connect to DTE's RX.
14	UIM_RESET	USIM_RST	DO	Reset signal of (U)SIM card	
15	GND	GND		Mini card ground	
16	UIM_VPP	RESERVED		Reserved	
17	RESERVED	RI	DO	Ring indication	
18	GND	GND		Mini card ground	
19	RESERVED	RESERVED		Reserved	
20	W_DISABLE#	W_DISABLE#	DI	Airplane mode control	Pulled up by default. Active low.
21	GND	GND		Mini card ground	
22	PERST#	PERST#	DI	Fundamental reset signal	Pulled up by default. Active low
23	PERn0	UART_CTS	DI	UART clear to send	Connect to DTE's RTS.
24	3.3Vaux	RESERVED		Reserved	
25	PERp0	UART_RTS	DO	UART request to send	Connect to DTE's CTS.
26	GND	GND		Mini card ground	
27	GND	GND		Mini card ground	
28	1.5V	NC		Not connected	
29	GND	GND		Mini card ground	

30	SMB_CLK	I2C_SCL	DO	I2C serial clock	Require external pull-up to 1.8 V.
31	PETn0	DTR	DI	Sleep mode control	
32	SMB_DATA	I2C_SDA	IO	I2C serial data	Require external pull-up to 1.8 V.
33	PETp0	RESERVED		Reserved	
34	GND	GND		Mini card ground	
35	GND	GND		Mini card ground	
36	USB_D-	USB_DM	IO	USB differential data (-)	Require differential impedance of 90 Ω.
37	GND	GND		Mini card ground	
38	USB_D+	USB_DP	IO	USB differential data (+)	Require differential impedance of 90 Ω.
39	3.3Vaux	VCC_3V3	PI	3.0–3.6 V, typically 3.3 V DC supply	
40	GND	GND		Mini card ground	
41	3.3Vaux	VCC_3V3	PI	3.0–3.6 V, typically 3.3 V DC supply	
42	LED_WWAN#	LED_WWAN#	OC	LED signal for indicating the network status of the module	Active low
43	GND	GND		Mini card ground	
44	LED_WLAN#	USIM_PRESENCE	DI	(U)SIM card insertion detection	
45	RESERVED	PCM_CLK	IO	PCM clock signal	
46	LED_WPAN#	RESERVED		Reserved	
47	RESERVED	PCM_DOUT	DO	PCM data output	
48	1.5V	NC		Not connected	
49	RESERVED	PCM_DIN	DI	PCM data input	

50	GND	GND		Mini card ground
51	RESERVED	PCM_SYNC	IO	PCM frame synchronization
52	3.3Vaux	VCC_3V3	PI	3.0–3.6 V, typically 3.3 V DC supply

**NOTE**

Keep all NC, reserved and unused pins unconnected.

### 3.1. Operating Modes

The following table briefly outlines the operating modes to be mentioned in the following chapters.

**Table 5: Overview of Operating Modes**

Mode	Details	
Normal Operation	Idle	Software is active. The module has registered on the network, and it is ready to send and receive data.
	Talk/Data	Network connection is ongoing. In this mode, the power consumption is decided by network setting and data transfer rate.
Minimum Functionality Mode	<b>AT+CFUN=0</b> command can set the module to a minimum functionality mode without removing the power supply. In this case, both RF function and (U)SIM card will be invalid.	
Airplane Mode	<b>AT+CFUN=4</b> command or W_DISABLE# pin can set the module to airplane mode. In this case, RF function will be invalid.	
Sleep Mode	In this mode, the current consumption of the module will be reduced to the minimal level. In this mode, the module can still receive paging message, SMS, voice call and TCP/UDP data from the network normally.	

## 3.2. Power Saving

### 3.2.1. Sleep Mode

EG25-G Mini PCIe is able to reduce its current consumption to a minimum value in sleep mode. There are three preconditions must be met to make the module enter sleep mode.

- Execute **AT+QSCLK=1** to enable sleep mode.
- Ensure the DTR is kept at high level or be kept open.
- The host's USB bus, which is connected with the module's USB interface, enters suspend state.

### 3.2.2. Airplane Mode

When the module enters airplane mode, the RF function will be disabled, and all AT commands related to it will be inaccessible. For more details, please refer to **Chapter 3.8.3**.

## 3.3. Power Supply

The following table shows pin definition of VCC\_3V3 pins and ground pins.

**Table 6: Definition of VCC\_3V3 and GND Pins**

Pin Name	Pin No.	I/O	Power Domain	Description
VCC_3V3	2, 39, 41, 52	PI	3.0–3.6 V	Typically 3.3 V DC supply
GND	4, 9, 15, 18, 21, 26, 27, 29, 34, 35, 37, 40, 43, 50			Mini card ground

The typical supply voltage of EG25-G Mini PCIe is 3.3 V. In the 2G network, the input peak current may reach 2.7 A during the transmitting time. Therefore, the power supply must be able to provide a rated output current of 2.7 A at least, and a bypass capacitor of no less than 470  $\mu$ F with low ESR should be used to prevent the voltage from dropping. If the switching power supply is used to supply power to the module, the power device and power supply routing traces of the switching power supply should avoid the antennas as much as possible to prevent EMI interference.

The following figure shows a reference design of power supply where R2 and R3 are 1% tolerance resistors and C3 is a low-ESR capacitor.

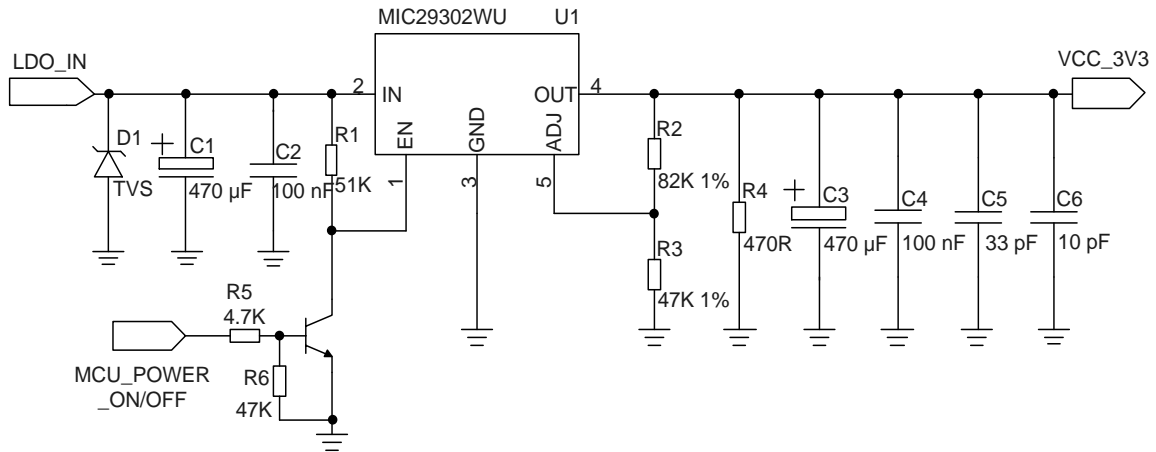

Figure 3: Reference Circuit of Power Supply

### 3.4. (U)SIM Interface

The (U)SIM interface circuitry meets ETSI and IMT-2000 requirements. Both 1.8 V and 3.0V (U)SIM cards are supported. The following table shows the pin definition of (U)SIM interface.

Table 7: Pin Definition of (U)SIM Interface

Pin Name	Pin No.	I/O	Power Domain	Description
USIM_VDD	8	PO	1.8/3.0 V	Power supply for (U)SIM card
USIM_DATA	10	IO	1.8/3.0 V	Data signal of (U)SIM card
USIM_CLK	12	DO	1.8/3.0 V	Clock signal of (U)SIM card
USIM_RST	14	DO	1.8/3.0 V	Reset signal of (U)SIM card
USIM_PRESENCE	44	DI	1.8 V	(U)SIM card insertion detection

EG25-G Mini PCIe supports (U)SIM card hot-plug via the USIM\_PRESENCE pin. The function supports low level and high level detections. By default, It is disabled, and can be configured via **AT+QSIMDET** command. Please refer to **document [2]** for details about the command.

The following figure shows a reference design for (U)SIM interface with an 8-pin (U)SIM card connector.

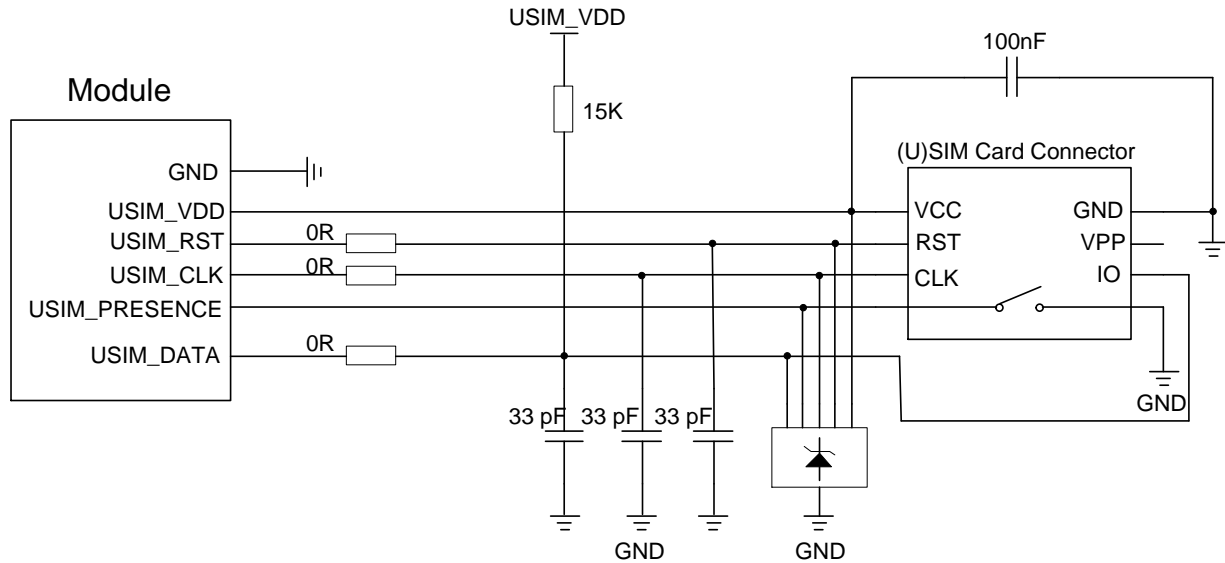

**Figure 4: Reference Circuit of (U)SIM Interface with an 8-pin (U)SIM Card Connector**

If (U)SIM card detection function is not needed, please keep USIM\_PRESENCE unconnected. A reference circuit for (U)SIM interface with a 6-pin (U)SIM card connector is illustrated in the following figure.

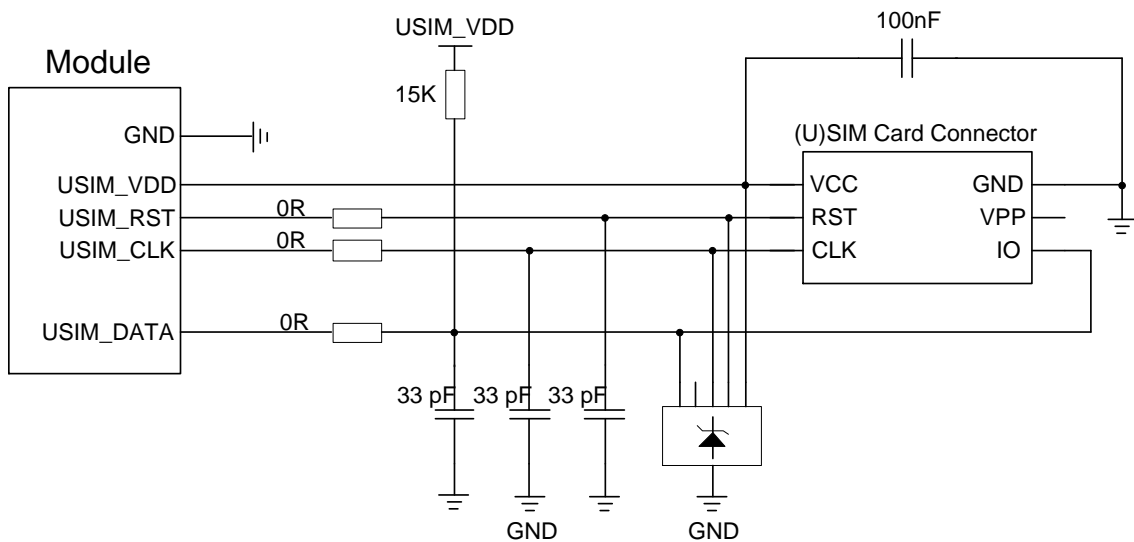

**Figure 5: Reference Circuit of (U)SIM Interface with a 6-pin (U)SIM Card Connector**

In order to enhance the reliability and availability of the (U)SIM card in customers' applications, please follow the criteria below in (U)SIM circuit design:

- Keep placement of (U)SIM card connector to the module as close as possible. Keep the trace length as less than 200 mm as possible.



- Keep (U)SIM card signals away from RF and power supply traces.
- To avoid cross-talk between USIM\_DATA and USIM\_CLK, keep them away from each other and shield them with surrounded ground.
- In order to offer good ESD protection, it is recommended to add a TVS diode with parasitic capacitance not exceeding 15 pF.
- The 0 Ω resistors should be added in series between the module and the (U)SIM card connector so as to facilitate debugging. The 33 pF capacitors are used for filtering interference of EGSM900. Please note that the (U)SIM peripheral circuit should be close to the (U)SIM card connector.
- The pull-up resistor on USIM\_DATA line can improve anti-jamming capability when long layout trace and sensitive occasion are applied, and should be placed close to the (U)SIM card connector.

**NOTE**

There are two types of EG25-G Mini PCIe, with or without integrated (U)SIM card connector, which is optional. The integrated (U)SIM card connector shares the same (U)SIM bus with the external (U)SIM card connector that connected to Mini PCI Express (U)SIM interface. It does not support (U)SIM card detection function, and cannot be used simultaneously with the external (U)SIM card connector. When unused, it has no any effect to the external (U)SIM card connector.

### 3.5. USB Interface

EG25-G Mini PCIe provides one integrated Universal Serial Bus (USB) interface which complies with USB 2.0 specification. It can only be used as a slave device. Meanwhile, it supports high speed (480 Mbps) mode and full speed (12 Mbps) mode. The USB interface is used for AT command communication, data transmission, GNSS NMEA output, software debugging and firmware upgrade.

The following table shows the pin definition of USB interface.

**Table 8: Pin Definition of USB Interface**

Pin Name	Pin No.	I/O	Description	Comment
USB_DM	36	IO	USB differential data (-)	Require differential impedance of 90 Ω
USB_DP	38	IO	USB differential data (+)	Require differential impedance of 90 Ω

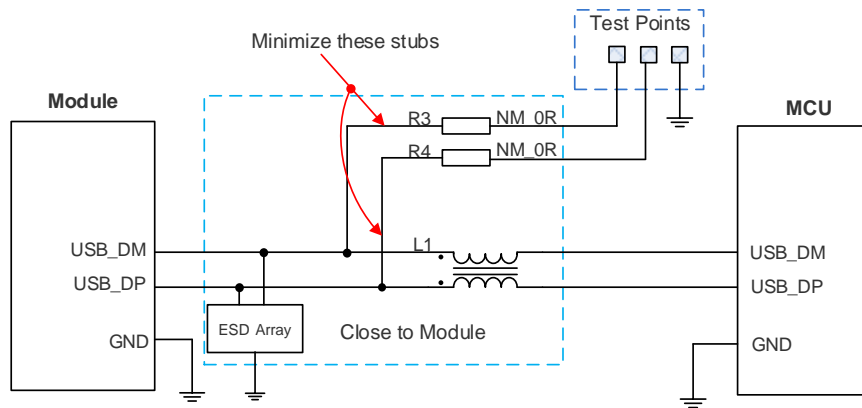

**Figure 6: Reference Circuit of USB Interface**

A common mode choke L1 is recommended to be added in series between the module and customer's MCU in order to suppress EMI spurious transmission. Meanwhile, the 0  $\Omega$  resistors (R3 and R4) should be added in series between the module and the test points so as to facilitate debugging, and the resistors are not mounted by default. In order to ensure the integrity of USB data line signal, L1/R3/R4 components must be placed close to the module, and also these resistors should be placed close to each other. The extra stubs of trace must be as short as possible.

The following principles should be complied with when design the USB interface, so as to meet USB 2.0 specification.

- It is important to route the USB signal traces as differential pairs with total grounding. The impedance of USB differential trace is 90  $\Omega$ .
- Do not route signal traces under crystals, oscillators, magnetic devices and RF signal traces. It is important to route the USB differential traces in inner layer with ground shielding on not only upper and lower layers but also right and left sides.
- Pay attention to the influence of junction capacitance of ESD protection components on USB data lines. Typically, the capacitance value should be less than 2 pF.
- Keep the ESD protection components to the USB connector as close as possible.

### 3.6. UART Interface

EG25-G Mini PCIe provides one main UART interface. The main UART interface supports 9600 bps, 19200 bps, 38400 bps, 57600 bps, 115200 bps and 230400 bps baud rates, and the default is 115200 bps. This interface supports RTS and CTS hardware flow control, and be used for AT command communication and data transmission. The following table shows the pin definition of the interface.

**Table 9: Pin Definition of Main UART Interface**

Pin Name	Pin No.	I/O	Power Domain	Description
UART_RX	11	DI	3.3 V	UART receive data
UART_TX	13	DO	3.3 V	UART transmit data
UART_CTS	23	DI	3.3 V	UART clear to send
UART_RTS	25	DO	3.3 V	UART request to send

The signal level of main UART interface is 3.3 V. When connecting to the peripheral MCU/RAM, customers need to pay attention to the signal direction. The reference circuit is as follows:

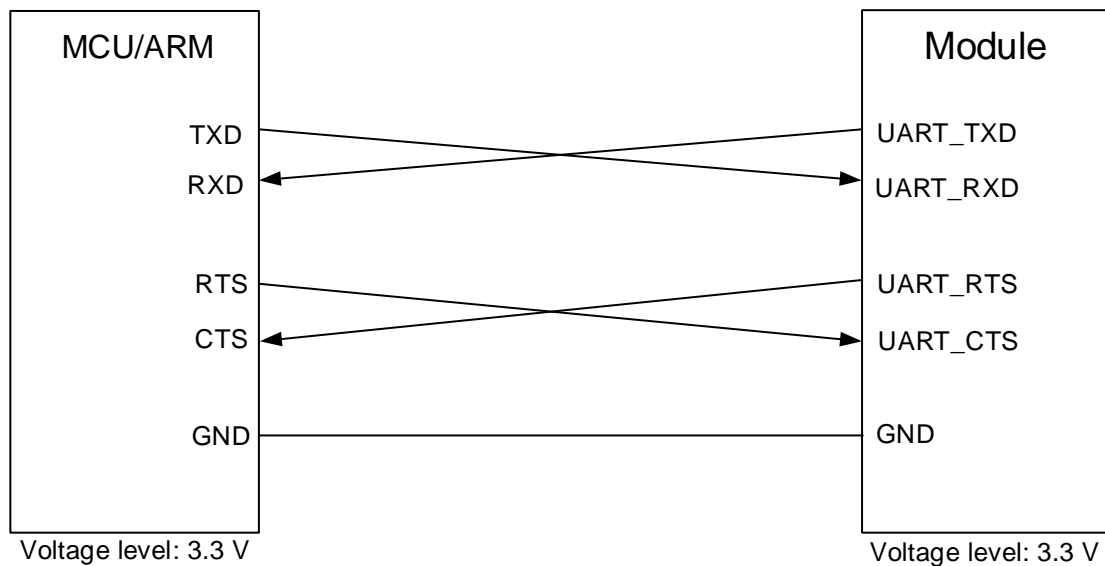

**Figure 7: Reference Circuit of Power Supply**

**NOTE**

**AT+IPR** can be used to set the baud rate of the main UART, and **AT+IFC** can be used to set the hardware flow control (hardware flow control is disabled by default). Please refer to **document [2]** for details.

### 3.7. PCM and I2C Interfaces

EG25-G Mini PCIe provides one Pulse Code Modulation (PCM) digital interface and one I2C interface.

The following table shows the pin definition of PCM and I2C interfaces that can be applied in audio codec design.

**Table 10: Pin Definition of PCM and I2C Interfaces**

Pin Name	Pin No.	I/O	Power Domain	Description
PCM_CLK	45	IO	1.8 V	PCM clock signal
PCM_DOUT	47	DO	1.8 V	PCM data output
PCM_DIN	49	DI	1.8 V	PCM data input
PCM_SYNC	51	IO	1.8 V	PCM frame synchronization
I2C_SCL	30	DO	1.8 V	I2C serial clock. Require external pull-up to 1.8 V.
I2C_SDA	32	IO	1.8 V	I2C serial data. Require external pull-up to 1.8 V.

EG25-G Mini PCIe provides one PCM digital interface, which supports 16-bit linear data format and the following modes:

- Primary mode (short frame synchronization, works as either master or slave)
- Auxiliary mode (long frame synchronization, works as master only)

In primary mode, the data is sampled on the falling edge of the PCM\_CLK and transmitted on the rising edge. The PCM\_SYNC falling edge represents the MSB. In this mode, the PCM interface supports 256 kHz, 512 kHz, 1024 kHz or 2048 kHz PCM\_CLK at 8 kHz PCM\_SYNC, and also supports 4096 kHz PCM\_CLK at 16 kHz PCM\_SYNC. The following figure shows the timing relationship in primary mode with 8 kHz PCM\_SYNC and 2048 kHz PCM\_CLK.

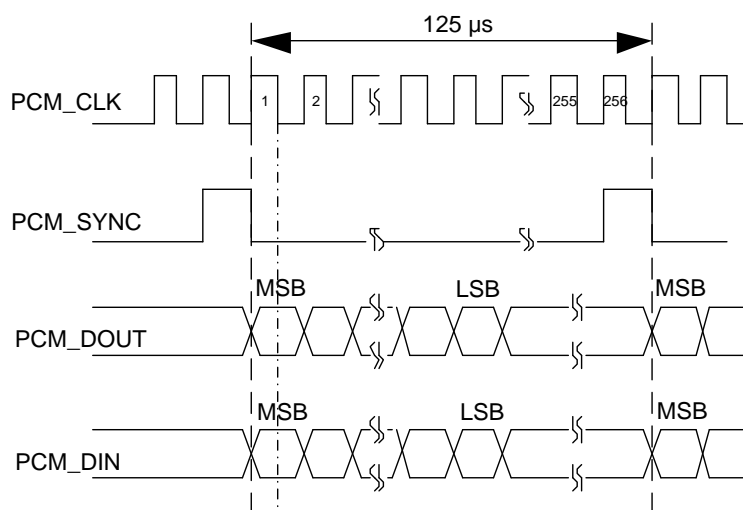

**Figure 8: Timing in Primary Mode**

In auxiliary mode, the data is sampled on the falling edge of the PCM\_CLK and transmitted on the rising edge. The PCM\_SYNC rising edge represents the MSB. In this mode, the PCM interface operates with a 256 kHz, 512 kHz, 1024 kHz or 2048 kHz PCM\_CLK and an 8 kHz, 50% duty cycle PCM\_SYNC. The following figure shows the timing relationship in auxiliary mode with 8 kHz PCM\_SYNC and 256 kHz PCM\_CLK.

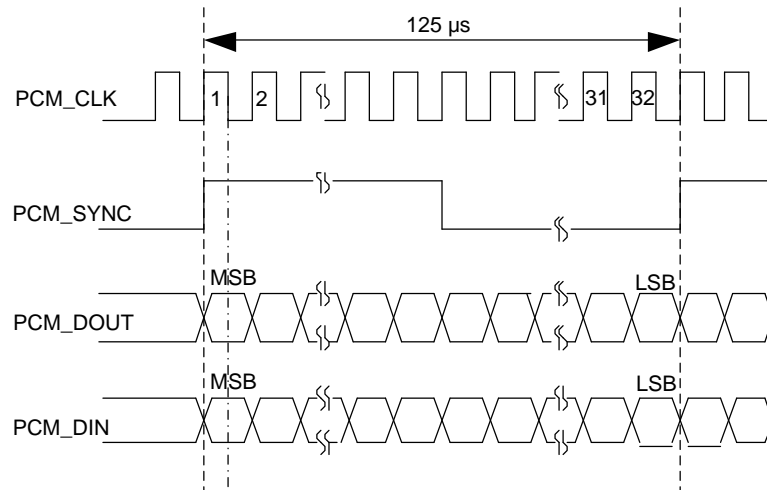

**Figure 9: Timing in Auxiliary Mode**

Clock and mode can be configured by AT command, and the default configuration is master mode using short frame synchronization format with 2048 kHz PCM\_CLK and 8 kHz PCM\_SYNC. In addition, EG25-G Mini PCIe’s firmware has integrated the configuration on some PCM codec’s application with I2C interface. Please refer to **document [2]** for details about **AT+QDAI** command.

The following figure shows a reference design of PCM and I2C interfaces with an external codec IC.

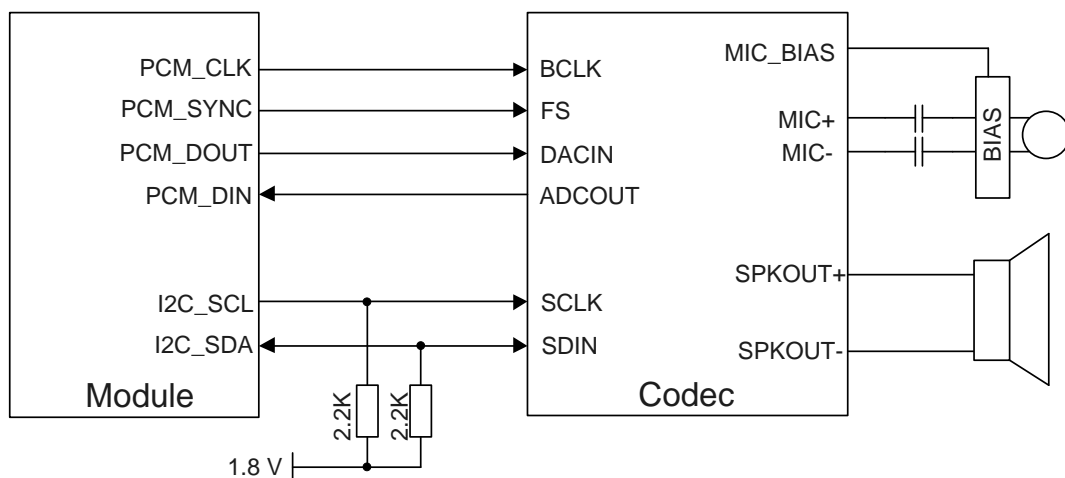

**Figure 10: Reference Circuit of PCM and I2C Application with Audio Codec**

### 3.8. Control and Indication Signals

The following table shows the pin definition of control and indication signals.

**Table 11: Pin Definition of Control and Indication Signals**

Pin Name	Pin No.	I/O	Power Domain	Description
RI	17	DO	3.3 V	Output signal used to wake up the host.
DTR	31	DI	3.3 V	Sleep mode control
W_DISABLE#	20	DI	3.3 V	Airplane mode control; Pulled up by default; Active low.
PERST#	22	DI	3.3 V	Fundamental reset signal; Active low.
LED_WWAN#	42	OC		LED signal for indicating the network status of the module; Active low
WAKE#	1	OC		Output signal to wake up the host.

#### 3.8.1. RI Signal

The RI signal can be used to wake up the host. When a URC returns, there will be the following behaviors on the RI pin after executing **AT+QCFG="risignaltype","physical"** command.

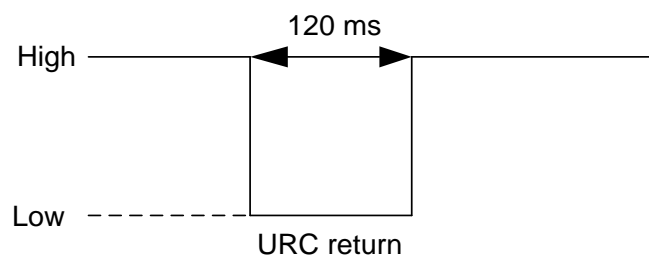

**Figure 11: RI Behaviors**

#### 3.8.2. DTR Signal

The DTR signal is used for sleep mode control. It is pulled up by default. When module is in sleep mode, driving it to low can wake up the module. For more details about the preconditions for module to enter sleep mode, please refer to **Chapter 3.4.1**.

### 3.8.3. W\_DISABLE# Signal

EG25-G Mini PCIe provides a W\_DISABLE# signal to disable or enable the RF function (excluding GNSS). The W\_DISABLE# pin is pulled up by default. Its control function for airplane mode is disabled by default, and **AT+QCFG="airplanecontrol",1** can be used to enable the function. Driving it low can make the module enter airplane mode.

**Table 12: Airplane Mode Controlled by Hardware Method**

W_DISABLE#	RF Function Status	Module Operation Mode
High level	RF enabled	Normal mode
Low level	RF disabled	Airplane mode

The RF function can also be enabled or disabled through AT commands **AT+CFUN**, and the details are as follows.

**Table 13: Airplane Mode Controlled by Software Method**

AT+CFUN=?	RF Function Status	Module Operation Mode
0	RF and (U)SIM disabled	Minimum functionality mode
1	RF enabled	Normal mode
4	RF disabled	Airplane mode

### 3.8.4. PERST# Signal

The PERST# signal can be used to force a hardware reset on the card. The module can be reset by driving the PERST# signal low for 150–460 ms and then releasing it. The PERST# signal is sensitive to interference. The traces should be as short as possible and be surrounded with ground. The reset scenario is illustrated in the following figure.

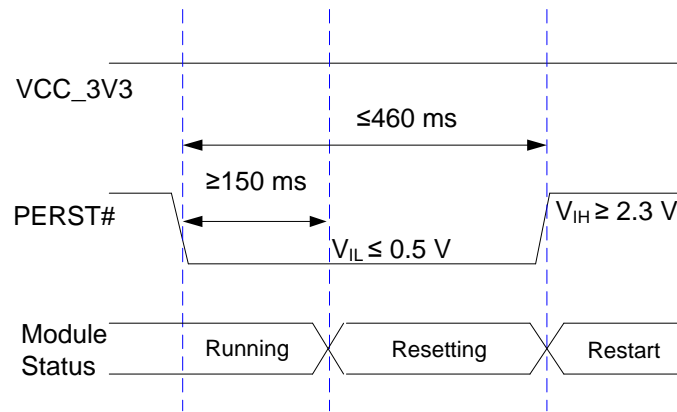
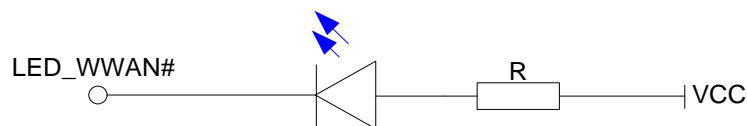

**Figure 12: Timing of Resetting Module**

### 3.8.5. LED\_WWAN# Signal

The LED\_WWAN# signal of EG25-G Mini PCIe is used to indicate the network status of the module, and can absorb a current up to 40 mA. According to the following circuit, in order to reduce the current of the LED, a resistor must be placed in series with the LED. The LED is emitting light when the LED\_WWAN# output signal is active low.

The LED is emitting light when the LED\_WWAN# output signal is low.



**Figure 13: LED\_WWAN# Signal Reference Circuit Diagram**

There are two indication modes for LED\_WWAN# signal to indicate network status, which can be switched through following AT commands:

- **AT+QCFG="ledmode",0** (Default setting)
- **AT+QCFG="ledmode",2**

The following tables show the detailed network status indications of the LED\_WWAN# signal.



**Table 14: Indications of Network Status (AT+QCFG="ledmode",0, Default Setting)**

Pin Status	Description
Flicker slowly (200 ms Low/1800 ms High)	Network searching
Flicker slowly (1800 ms Low/200 ms High)	Idle
Flicker quickly (125 ms Low/125 ms High)	Data transfer is ongoing
Always Low	Voice calling

**Table 15: Indications of Network Status (AT+QCFG="ledmode",2)**

Pin Status	Description
Low Level (Light ON)	Registered on network successfully
High-impedance (Light OFF)	<ul style="list-style-type: none"> <li>● No network coverage or not registered</li> <li>● W_DISABLE# signal is at low level. (Disable the RF)</li> <li>● <b>AT+CFUN=0, AT+CFUN=4</b></li> </ul>

### 3.8.6. WAKE# Signal

The WAKE# signal is an open collector signal which is similar to RI signal, but a host pull-up resistor and **AT+QCFG="risignalttype","physical"** command are required. When a URC returns, a 120 ms low level pulse will be outputted. The state of WAKE# signal is shown as below.

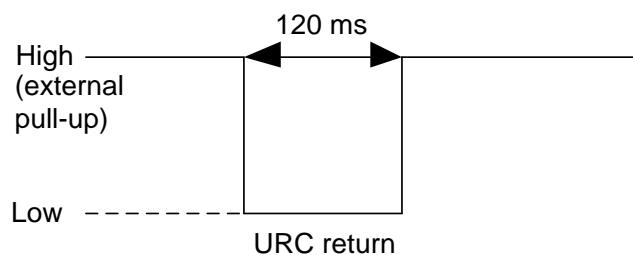

**Figure 14: WAKE# Behaviors**

# 4 GNSS Receiver

## 4.1. General Description

EG25-G Mini PCIe includes a fully integrated global navigation satellite system solution that supports Gen8C-Lite of Qualcomm (GPS, GLONASS, BeiDou/Compass, Galileo and QZSS). Additionally, it supports standard NMEA-0183 protocol, and outputs NMEA sentences at 1 Hz data update rate via USB interface by default.

By default, EG25-G Mini PCIe GNSS engine is switched off. It has to be switched on via AT command. For more details about GNSS engine technology and configurations, please refer to **document [3]**.

## 4.2. GNSS Performance

The following table shows GNSS performance of EG25-G Mini PCIe.

**Table 15: GNSS Performance**

Parameter	Description	Conditions	Typ.	Unit
Sensitivity (GNSS)	Cold start	Autonomous	-146	dBm
	Reacquisition	Autonomous	-156	dBm
	Tracking	Autonomous	-157	dBm
TTFF (GNSS)	Cold start @ open sky	Autonomous	35	s
		XTRA enabled	15	s
	Warm start @ open sky	Autonomous	28	s
		XTRA enabled	3	s
	Hot start @ open sky	Autonomous	2	s
		XTRA enabled	1.6	s

Accuracy (GNSS)	CEP-50	Autonomous @ open sky	< 2.5	m
-----------------	--------	-----------------------	-------	---

#### NOTES

1. Tracking sensitivity: the minimum GNSS signal power at which the module can maintain lock (keep positioning for at least 3 minutes continuously).
2. Reacquisition sensitivity: the minimum GNSS signal power required for the module to maintain lock within 3 minutes after loss of lock.
3. Cold start sensitivity: the minimum GNSS signal power at which the module can fix position successfully within 3 minutes after executing cold start command.

### 4.3. GNSS Frequency

The following table shows the GNSS frequency of EG25-G Mini PCIe.

**Table 16: GNSS Frequency**

Type	Frequency	Unit
GPS	1575.42 ±1.023	MHz
GLONASS	1597.5–1605.8	MHz
Galileo	1575.42 ±2.046	MHz
BeiDou (Compass)	1561.098 ±2.046	MHz
QZSS	1575.42	MHz

# 5 Antenna Connection

## 5.1. Antenna Connectors

EG25-G Mini PCIe is mounted with three antenna connectors for external antenna connection: a main antenna connector, an Rx-diversity antenna connector, and a GNSS antenna connector. And Rx-diversity function is enabled by default. The impedance of the antenna connectors is 50  $\Omega$ .

### 5.1.1. Operating Frequency

The following table shows the operating frequencies of EG25-G Mini PCIe.

**Table 17: Operating Frequencies**

3GPP Band	Transmit	Receive	Unit
GSM850	824–849	869–894	MHz
EGSM900	880–915	925–960	MHz
DCS1800	1710–1785	1805–1880	MHz
PCS1900	1850–1910	1930–1990	MHz
WCDMA B1	1920–1980	2110–2170	MHz
WCDMA B2	1850–1910	1930–1990	MHz
WCDMA B4	1710–1755	2110–2155	MHz
WCDMA B5	824–849	869–894	MHz
WCDMA B6	830–840	875–885	MHz
WCDMA B8	880–915	925–960	MHz
WCDMA B19	830–845	875–890	MHz

---

LTE-FDD B1	1920–1980	2110–2170	MHz
LTE-FDD B2	1850–1910	1930–1990	MHz
LTE-FDD B3	1710–1785	1805–1880	MHz
LTE-FDD B4	1710–1755	2110–2155	MHz
LTE-FDD B5	824–849	869–894	MHz
LTE-FDD B7	2500–2570	2620–2690	MHz
LTE-FDD B8	880–915	925–960	MHz
LTE-FDD B12	699–716	729–746	MHz
LTE-FDD B13	777–787	746–756	MHz
LTE-FDD B18	815–830	860–875	MHz
LTE-FDD B19	830–845	875–890	MHz
LTE-FDD B20	832–862	791–821	MHz
LTE-FDD B25	1850–1915	1930–1995	MHz
LTE-FDD B26	814–849	859–894	MHz
LTE-FDD B28	703–748	758–803	MHz
LTE-TDD B38	2570–2620	2570–2620	MHz
LTE-TDD B39	1880–1920	1880–1920	MHz
LTE-TDD B40	2300–2400	2300–2400	MHz
LTE-TDD B41	2496–2690	2496–2690	MHz

---

## 5.2. Antenna Requirements

The following table shows the requirements on main antenna, Rx-diversity antenna and GNSS antenna.

**Table 18: Antenna Requirements**

Type	Requirements
GNSS <sup>1)</sup>	Frequency range: 1559–1609 MHz Polarization: RHCP or linear VSWR: < 2 (Typ.) Passive antenna gain: > 0 dBi Active antenna noise figure: <1.5 dB Active antenna gain: > 0 dBi Active antenna embedded LNA gain: < 17 dB
GSM/UMTS/LTE	VSWR: $\leq 2$ Efficiency: > 30% Max input power: 50 W Input impedance: 50 $\Omega$ Cable insertion loss: < 1 dB (GSM850, EGSM900, WCDMA B5/B6/B8/B19, LTE-FDD B5/B8/B12/ B13/B18/B19/B20/B26/B28) Cable insertion loss: < 1.5 dB (DCS1800, PCS1900, WCDMA B1/B2/B4, LTE-FDD B1/B2/B3/B4/B25, LTE-TDD B39) Cable insertion loss: < 2 dB (LTE-FDD B7, LTE-TDD B38/B40/B41)

### NOTES

1. It is recommended to use a passive GNSS antenna when LTE B13 or B14 is supported, as the use of active antenna may generate harmonics which will affect the GNSS performance.
2. Since the GNSS port has a 2.85 V voltage output, a passive antenna that causes shorting to GND, such as PIFA antenna is not recommended.

### 5.3. Recommended Mating Plugs for Antenna Connection

EG25-G Mini PCIe is mounted with RF connectors (receptacles) for convenient antenna connection. The dimensions of the antenna connectors are shown as below.

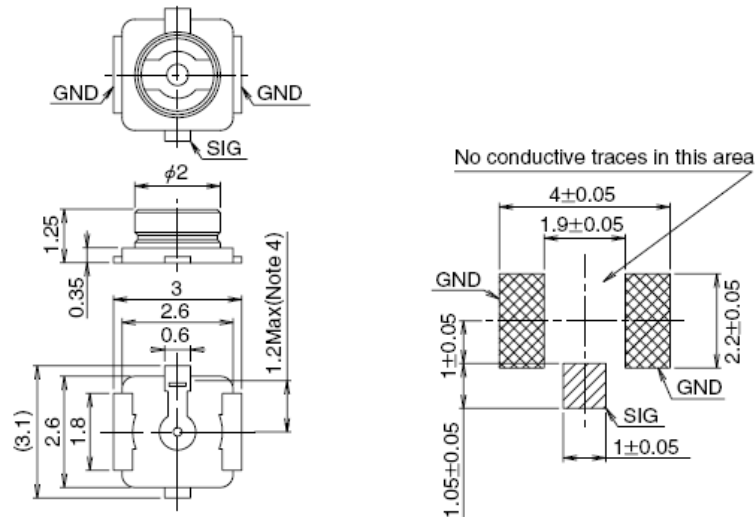

Figure 15: Dimensions of the Receptacle RF Connectors (Unit: mm)

U.FL-LP mating plugs listed in the following figure can be used to match the receptacles.

Part No.	U.FL-LP-040	U.FL-LP-066	U.FL-LP(V)-040	U.FL-LP-062	U.FL-LP-088
Mated Height	2.5mm Max. (2.4mm Nom.)	2.5mm Max. (2.4mm Nom.)	2.0mm Max. (1.9mm Nom.)	2.4mm Max. (2.3mm Nom.)	2.4mm Max. (2.3mm Nom.)
Applicable cable	Dia. 0.81mm Coaxial cable	Dia. 1.13mm and Dia. 1.32mm Coaxial cable	Dia. 0.81mm Coaxial cable	Dia. 1mm Coaxial cable	Dia. 1.37mm Coaxial cable
Weight (mg)	53.7	59.1	34.8	45.5	71.7
RoHS	YES				

Figure 16: Mechanicals of U.FL-LP Mating Plugs

The following figure describes the space factor of mating plugs.

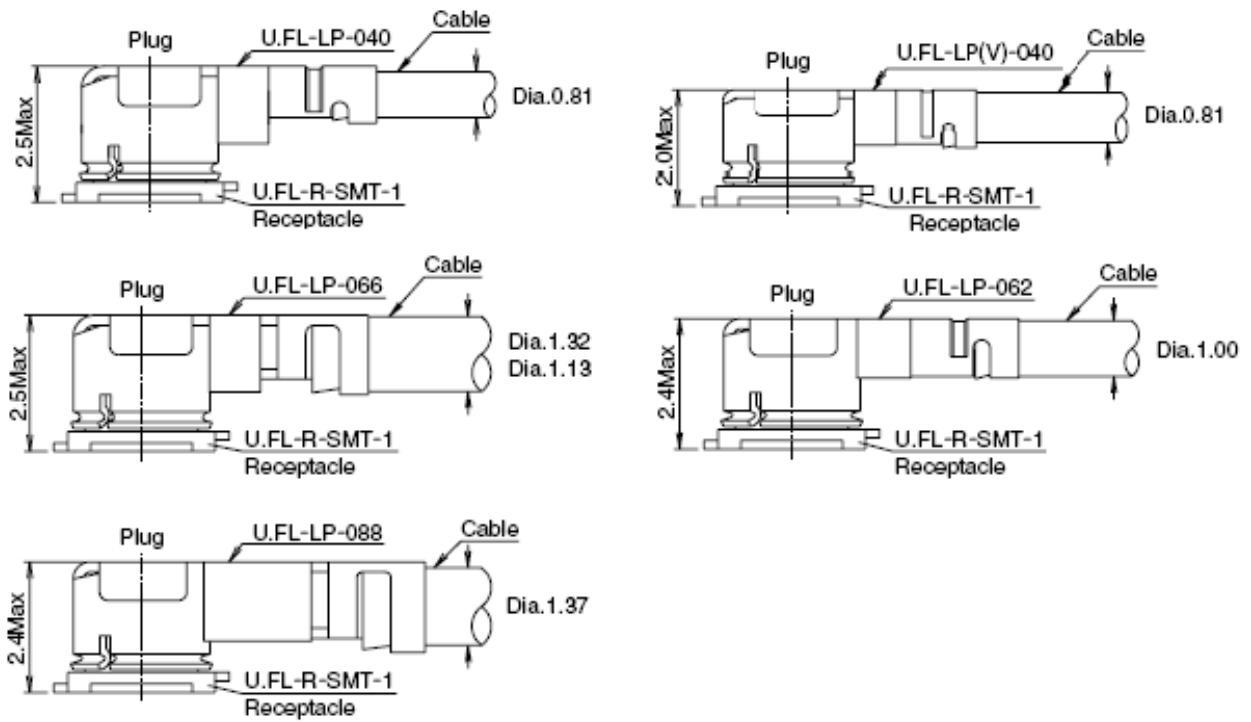

**Figure 17: Space Factor of Mating Plugs (Unit: mm)**

For more details of the recommended mating plugs, please visit <http://www.hirose.com>.



# 6 Electrical, Reliability and Radio Characteristics

## 6.1. General Description

This chapter mainly describes the following electrical and radio characteristics of EG25-G Mini PCIe:

- Power supply requirements
- I/O requirements
- RF characteristics
- GNSS receiver
- ESD characteristics
- Current consumption
- Thermal consideration

## 6.2. Power Supply Requirements

The input voltage of EG25-G Mini PCIe is 3.0–3.6 V, as specified by *PCI Express Mini CEM Specifications 1.2*. The following table shows the power supply requirements of EG25-G Mini PCIe.

**Table 19: Power Supply Requirements**

Parameter	Description	Min.	Typ.	Max.	Unit
VCC_3V3	Power Supply	3.0	3.3	3.6	V

## 6.3. I/O Requirements

The following table shows the I/O requirements of EG25-G Mini PCIe.

**Table 20: I/O Requirements**

Parameter	Description	Min.	Max.	Unit
V <sub>IH</sub>	Input High Voltage	0.7 × VCC_3V3	VCC_3V3 + 0.3	V
V <sub>IL</sub>	Input Low Voltage	-0.3	0.3 × VCC_3V3	V
V <sub>OH</sub>	Output High Voltage	VCC_3V3 - 0.5	VCC_3V3	V
V <sub>OL</sub>	Output Low Voltage	0	0.4	V

### NOTES

1. The PCM and I2C interfaces belong to 1.8 V power domain and other I/O interfaces belong to VCC\_3V3 power domain.
2. The maximum voltage value of V<sub>IL</sub> for PERST# signal and W\_DISABLE# signal is 0.5 V.

## 6.4. RF Characteristics

The following tables show the conducted RF output power and receiving sensitivity of EG25-G Mini PCIe module.

**Table 21: EG25-G Mini PCIe Conducted RF Output Power**

Frequency Bands	Max.	Min.
GSM850/EGSM900	33 dBm ±2 dB	5 dBm ±5 dB
DCS1800/PCS1900	30 dBm ±2 dB	0 dBm ±5 dB
GSM850/EGSM900 (8-PSK)	27 dBm ±3 dB	5 dBm ±5 dB
DCS1800/PCS1900 (8-PSK)	26 dBm ±3 dB	0 dBm ±5 dB
WCDMA B1/B2/B4/B5/B6/B8/B19	24 dBm +1/-3 dB	< -49 dBm
LTE-FDD B1/B2/B3/B4/B5/B7/B8/B12	23 dBm ±2 dB	< -39 dBm

LTE-FDD B13/B18/B19/B20/B25/B26/B28	23 dBm $\pm$ 2 dB	< -39 dBm
LTE-TDD B38/B39/B40/B41	23 dBm $\pm$ 2 dB	< -39 dBm

## NOTES

1. In GPRS 4 slots TX mode, the maximum output power is reduced by 3.0 dB. The design conforms to the GSM specification as described in **Chapter 13.16** of 3GPP TS 51.010-1.
2. EG25-G Mini PCIe supports LTE B25, and Qorvo Phase 6 PAMiD QM77031 in the module does not actually support LTE B25. Qorvo has confirmed that the SAW integrated in the PA can support LTE B2, but B25 can work at the same frequency as B2. B25 is 5 MHz wider than B2. Therefore, the sensitivity of the Rx channels 8630–8689 is poor, and there is a big gap with the 3GPP standard. At a high temperature of 75 °C, the maximum power of channels 26640–26689 will be reduced by about 2.5 dB.

**Table 22: EG25-G Mini PCIe Conducted RF Receiving Sensitivity**

Frequency Bands	Primary	Diversity	SIMO <sup>1)</sup>	3GPP (SIMO)
GSM850	-108 dBm	NA	NA	-102 dBm
EGSM900	-108 dBm	NA	NA	-102 dBm
DCS1800	-107.5 dBm	NA	NA	-102 dBm
PCS1900	-107.5 dBm	NA	NA	-102 dBm
WCDMA B1	-108.2 dBm	-108.5 dBm	-109.2 dBm	-106.7 dBm
WCDMA B2	-109.5 dBm	-109 dBm	-110 dBm	-104.7 dBm
WCDMA B4	-109.5 dBm	NA	NA	-103.7 dBm
WCDMA B5	-109 dBm	-109.5 dBm	-110 dBm	-104.7 dBm
WCDMA B6	-109 dBm	-109.5 dBm	-110.5 dBm	-106.7 dBm
WCDMA B8	-109.2 dBm	NA	NA	-103.7 dBm
WCDMA B19	-109 dBm	-109.5 dBm	-110.5 dBm	-106.7 dBm
LTE-FDD B1 (10 MHz)	-97.3 dBm	-98.3 dBm	-99.5 dBm	-96.3 dBm
LTE-FDD B2 (10 MHz)	-98 dBm	-99 dBm	-99.9 dBm	-94.3 dBm
LTE-FDD B3 (10 MHz)	-97.4 dBm	-98.1 dBm	-99.8 dBm	-93.3 dBm

LTE-FDD B4 (10 MHz)	-97.7 dBm	-98.2 dBm	-99.7 dBm	-96.3 dBm
LTE-TDD B5 (10 MHz)	-98 dBm	-98.5 dBm	-99.9 dBm	-94.3 dBm
LTE-TDD B7 (10 MHz)	-97.3 dBm	-97.3 dBm	-99.1 dBm	-94.3 dBm
LTE-TDD B8 (10 MHz)	-98 dBm	-98.1 dBm	-99.8 dBm	-93.3 dBm
LTE-TDD B12 (10 MHz)	-98 dBm	-98.1 dBm	-99.9 dBm	-93.3 dBm
LTE-TDD B13 (10 MHz)	-98 dBm	-98.1 dBm	-100.1 dBm	-93.3 dBm
LTE-TDD B18 (10 MHz)	-98 dBm	-99.5 dBm	-100 dBm	-96.3 dBm
LTE-TDD B19 (10 MHz)	-98 dBm	-99 dBm	-99.8 dBm	-96.3 dBm
LTE-TDD B20 (10 MHz)	-98 dBm	-98.8 dBm	-99.7 dBm	-93.3 dBm
LTE-TDD B25 (10 MHz)	-98 dBm	-98 dBm	-100.2 dBm	-92.8 dBm
LTE-TDD B26 (10 MHz)	-98 dBm	-98.8 dBm	-100 dBm	-93.8 dBm
LTE-TDD B28 (10 MHz)	-98.1 dBm	-98.9 dBm	-99.8 dBm	-94.8 dBm
LTE-TDD B38 (10 MHz)	-96.8 dBm	-96.9 dBm	-98.3 dBm	-96.3 dBm
LTE-TDD B39 (10 MHz)	-98 dBm	-98.2 dBm	-99.8 dBm	-96.3 dBm
LTE-TDD B40 (10 MHz)	-97.7 dBm	-97.5 dBm	-99.7 dBm	-96.3 dBm
LTE-TDD B41 (10 MHz)	-96.8 dBm	-96.0 dBm	-98 dBm	-94.3 dBm

**NOTE**

<sup>1)</sup> SIMO is a smart antenna technology that uses a single antenna at the transmitter side and two antennas at the receiver side, which can improve Rx performance.

## 6.5. ESD Characteristics

The following table shows the ESD characteristics of EG25-G Mini PCIe.

**Table 23: ESD Characteristics of EG25-G Mini PCIe**

Tested Interfaces	Contact Discharge	Air Discharge	Unit
Power Supply and GND	+/-5	+/-10	kV
Antenna Interfaces	+/-4	+/-8	kV
USB Interface	+/-4	+/-8	kV
(U)SIM Interface	+/-4	+/-8	kV
Others	+/-0.5	+/-1	kV

## 6.6. Current Consumption

**Table 24: Current Consumption of EG25-G Mini PCIe**

Parameter	Description	Conditions	Typ.	Unit
I <sub>BAT</sub>	Sleep state	AT+CFUN=0 (USB disconnected)	2.1	mA
		EGSM @ DRX = 2 (USB disconnected)	4.2	mA
		EGSM @ DRX = 5 (USB disconnected)	3.6	mA
		EGSM @ DRX = 5 (USB suspend)	3.9	mA
		EGSM @ DRX = 9 (USB disconnected)	3.4	mA
		DCS1800 @ DRX = 2 (USB disconnected)	3.6	mA
		DCS1800 @ DRX = 5 (USB disconnected)	3.0	mA
		DCS1800 @ DRX = 5 (USB suspend)	3.2	mA
		DCS1800 @ DRX = 9 (USB disconnected)	2.8	mA
		WCDMA @ PF = 64 (USB suspend)	3.9	mA

	WCDMA @ PF = 128 (USB disconnected)	3.2	mA
	WCDMA @ PF = 256 (USB disconnected)	2.9	mA
	WCDMA @ PF = 512 (USB disconnected)	2.7	mA
	LTE-FDD @ PF = 32 (USB disconnected)	5.4	mA
	LTE-FDD @ PF = 64 (USB disconnected)	3.9	mA
	LTE-FDD @ PF = 64 (USB suspend)	4.1	mA
	LTE-FDD @ PF = 128 (USB disconnected)	3.2	mA
	LTE-FDD @ PF = 256 (USB disconnected)	2.8	mA
	LTE-TDD @ PF = 32 (USB disconnected)	5.4	mA
	LTE-TDD @ PF = 64 (USB disconnected)	3.8	mA
	LTE-TDD @ PF = 64 (USB suspend)	4.1	mA
	LTE-TDD @ PF = 128 (USB disconnected)	3.2	mA
	LTE-TDD @ PF = 256 (USB disconnected)	2.8	mA
Idle state	EGSM DRX = 5 (USB disconnected)	22.1	mA
	EGSM DRX = 5 (USB connected)	35.1	mA
	WCDMA @ PF = 64 (USB disconnected)	22.3	mA
	WCDMA @ PF = 64 (USB connected)	35.3	mA
	LTE-FDD @ PF = 64 (USB disconnected)	22.2	mA
	LTE-FDD @ PF = 64 (USB connected)	35.2	mA
	LTE-TDD @ PF = 64 (USB disconnected)	22.4	mA
	LTE-TDD @ PF = 64 (USB connected)	35.5	mA
GPRS data transfer (GNSS OFF)	GSM850 1UL/4DL @ 32.1 dBm	376.8	mA
	GSM850 2UL/3DL @ 30.0 dBm	547	mA
	GSM850 3UL/2DL @ 28.9 dBm	701	mA

	GSM850 4UL/1DL @ 27.6 dBm	794	mA
	EGSM900 1UL/4DL @ 32.2 dBm	344.4	mA
	EGSM900 2UL/3DL @ 31.2 dBm	560.4	mA
	EGSM900 3UL/2DL @ 29.2 dBm	649.4	mA
	EGSM900 4UL/1DL @ 27.9 dBm	741.2	mA
	DCS1800 1UL/4DL @ 29.2 dBm	205.2	mA
	DCS1800 2UL/3DL @ 28.5 dBm	333.7	mA
	DCS1800 3UL/2DL @ 26.5 dBm	400.2	mA
	DCS1800 4UL/1DL @ 25.7 dBm	480	mA
	PCS1900 1UL/4DL @ 29.2 dBm	227.7	mA
	PCS1900 2UL/3DL @ 28.1 dBm	363.8	mA
	PCS1900 3UL/2DL @ 26.3 dBm	440	mA
	PCS1900 4UL/1DL @ 24.9 dBm	507.2	mA
	GSM850 1UL/4DL @ 26.3 dBm	212	mA
	GSM850 2UL/3DL @ 25.1 dBm	337	mA
	GSM850 3UL/2DL @ 23.3 dBm	415	mA
	GSM850 4UL/1DL @ 22.2 dBm	487	mA
	EGSM900 1UL/4DL @ 26.6 dBm	195	mA
EDGE data transfer (GNSS OFF)	EGSM900 2UL/3DL @ 25.3 dBm	312	mA
	EGSM900 3UL/2DL @ 23.7 dBm	392.7	mA
	EGSM900 4UL/1DL @ 22.5 dBm	463.5	mA
	DCS1800 1UL/4DL @ 25.5 dBm	156.8	mA
	DCS1800 2UL/3DL @ 25.0 dBm	260	mA
	DCS1800 3UL/2DL @ 23.8 dBm	334	mA
	DCS1800 4UL/1DL @ 22.6 dBm	405	mA

	PCS1900 1UL/4DL @ 25.4 dBm	169	mA
	PCS1900 2UL/3DL @ 24.6 dBm	272	mA
	PCS1900 3UL/2DL @ 23.3 dBm	350	mA
	PCS1900 4UL/1DL @ 22.0 dBm	418	mA
	WCDMA B1 HSDPA @ 22.5 dBm	735.9	mA
	WCDMA B2 HSDPA @ 22.6 dBm	740.6	mA
	WCDMA B4 HSDPA @ 22.6 dBm	776.8	mA
	WCDMA B5 HSDPA @ 22.3 dBm	670.8	mA
	WCDMA B6 HSDPA @ 22.4 dBm	675.3	mA
	WCDMA B8 HSDPA @ 22.5 dBm	748.3	mA
WCDMA data transfer (GNSS OFF)	WCDMA B19 HSDPA @ 22.4 dBm	676.8	mA
	WCDMA B1 HSUPA @ 22.3 dBm	730.8	mA
	WCDMA B2 HSUPA @ 22.3 dBm	730.5	mA
	WCDMA B4 HSUPA @ 22.0 dBm	742.6	mA
	WCDMA B5 HSUPA @ 22.3 dBm	713.9	mA
	WCDMA B6 HSUPA @ 22.4 dBm	717.9	mA
	WCDMA B8 HSUPA @ 22.0 dBm	712	mA
	WCDMA B19 HSUPA @ 22.3 dBm	710.9	mA
		LTE-FDD B1 @ 22.8 dBm	966.8
	LTE-FDD B2 @ 22.7 dBm	1021.8	mA
	LTE-FDD B3 @ 23.0 dBm	1017.7	mA
LTE data transfer (GNSS OFF)	LTE-FDD B4 @ 23.4 dBm	1052.3	mA
	LTE-FDD B5 @ 23.5 dBm	886.3	mA
	LTE-FDD B7 @ 23.6 dBm	1114	mA
	LTE-FDD B8 @ 23.6 dBm	988.7	mA



	LTE-FDD B12 @ 23.1 dBm	811.4	mA
	LTE-FDD B13 @ 23.7 dBm	910.7	mA
	LTE-FDD B18 @ 23.5 dBm	1038.5	mA
	LTE-FDD B19 @ 23.5 dBm	938.8	mA
	LTE-FDD B20 @ 23.3 dBm	1014	mA
	LTE-FDD B25 @ 22.7 dBm	1001.3	mA
	LTE-FDD B26 @ 23.4 dBm	999.4	mA
	LTE-FDD B28 @ 23.6 dBm	1004.7	mA
	LTE-TDD B38 @ 23.3 dBm	573.8	mA
	LTE-TDD B39 @ 23.2 dBm	482.8	mA
	LTE-TDD B40 @ 22.7 dBm	508.2	mA
	LTE-TDD B41 @ 23.3 dBm	561.9	mA
GSM voice call	GSM850PCL = 5 @ 31.8 dBm	375.6	mA
	EGSM900PCL = 5 @ 32.2 dBm	366	mA
	DCS1800PCL = 0 @ 29.2 dBm	221	mA
	PCS1900PCL = 0 @ 29.0 dBm	236.6	mA
WCDMA voice call	WCDMA B1 @ 23.0 dBm	780.3	mA
	WCDMA B2 @ 23.1 dBm	796.3	mA
	WCDMA B4 @ 23.2 dBm	846.2	mA
	WCDMA B5 @ 23.2 dBm	731	mA
	WCDMA B6 @ 23.2 dBm	739.4	mA
	WCDMA B8 @ 23.1 dBm	822.6	mA
	WCDMA B19 @ 23.0 dBm	720.9	mA

**Table 25: GNSS Current Consumption of EG25-G Mini PCIe**

Parameter	Description	Conditions	Typ.	Unit
I <sub>VBAT</sub> (GNSS)	Searching (AT+CFUN=0)	Cold start @ Passive Antenna	67	mA
		Lost state @ Passive Antenna	66	mA
	Tracking (AT+CFUN=0)	Instrument Environment	46	mA

## 6.7. Thermal Consideration

In order to achieve better performance of the module, it is recommended to comply with the following principles for thermal consideration:

- On customers' PCB design, please keep placement of the PCI Express Mini Card away from heating sources.
- Do not place components on the PCB area where the module is mounted, in order to facilitate adding of heatsink.
- Do not apply solder mask on the PCB area where the module is mounted, so as to ensure better heat dissipation performance.
- The reference ground of the area where the module is mounted should be complete, and add ground vias as many as possible for better heat dissipation.
- Add a heatsink on the top of the module and the heatsink should be designed with as many fins as possible to increase heat dissipation area. Meanwhile, a thermal pad with high thermal conductivity should be used between the heatsink and module.
- Add a thermal pad with appropriate thickness at the bottom of the module to conduct the heat to PCB.

The following figure shows the reference heatsink design.

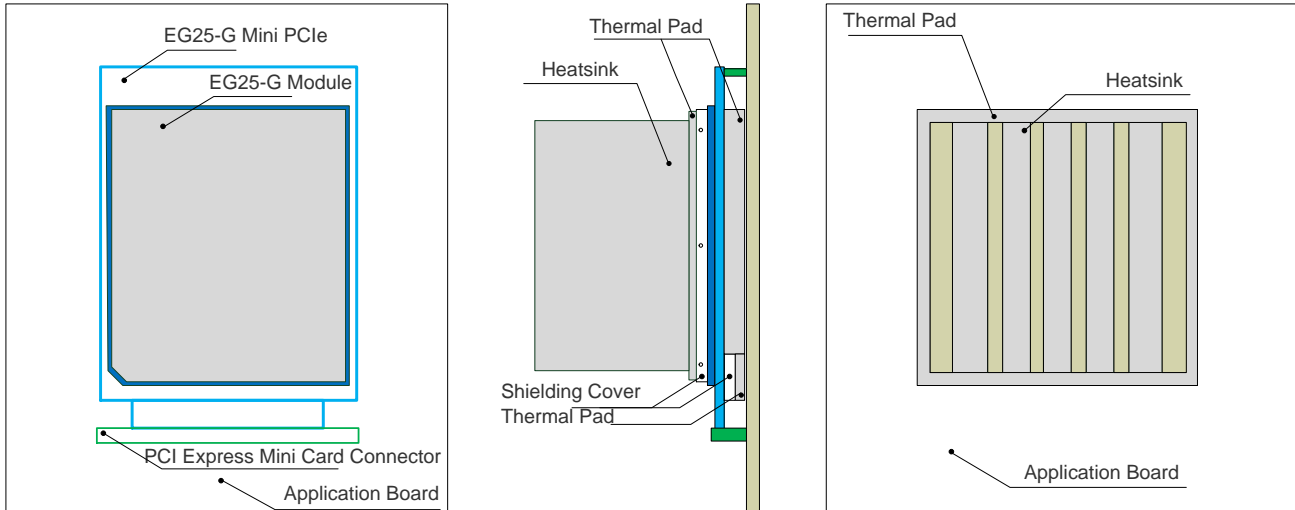

Figure 18: Reference Heatsink Design

#### NOTES

1. The module offers the best performance when the internal BB chip stays below 105 °C. When the maximum temperature of the BB chip reaches or exceeds 105 °C, the module works normal but provides reduced performance (such as RF output power, data rate, etc.). When the maximum BB chip temperature reaches or exceeds 115 °C, the module will disconnect from the network, and it will recover to network connected state after the maximum temperature falls below 115 °C. Therefore, the thermal design should be maximally optimized to make sure the maximum BB chip temperature always maintains below 105 °C. Customers can execute **AT+QTEMP** command and get the maximum BB chip temperature from the first returned value.
2. For more detailed guidelines on thermal design, please refer to **document [4]**.

# 7 Dimensions and Packaging

## 7.1. General Description

This chapter mainly describes mechanical dimensions as well as packaging specification of EG25-G Mini PCIe module. All dimensions are measured in millimeter (mm), and the dimensional tolerances are  $\pm 0.05$  mm unless otherwise specified.

## 7.2. Mechanical Dimensions of EG25-G Mini PCIe

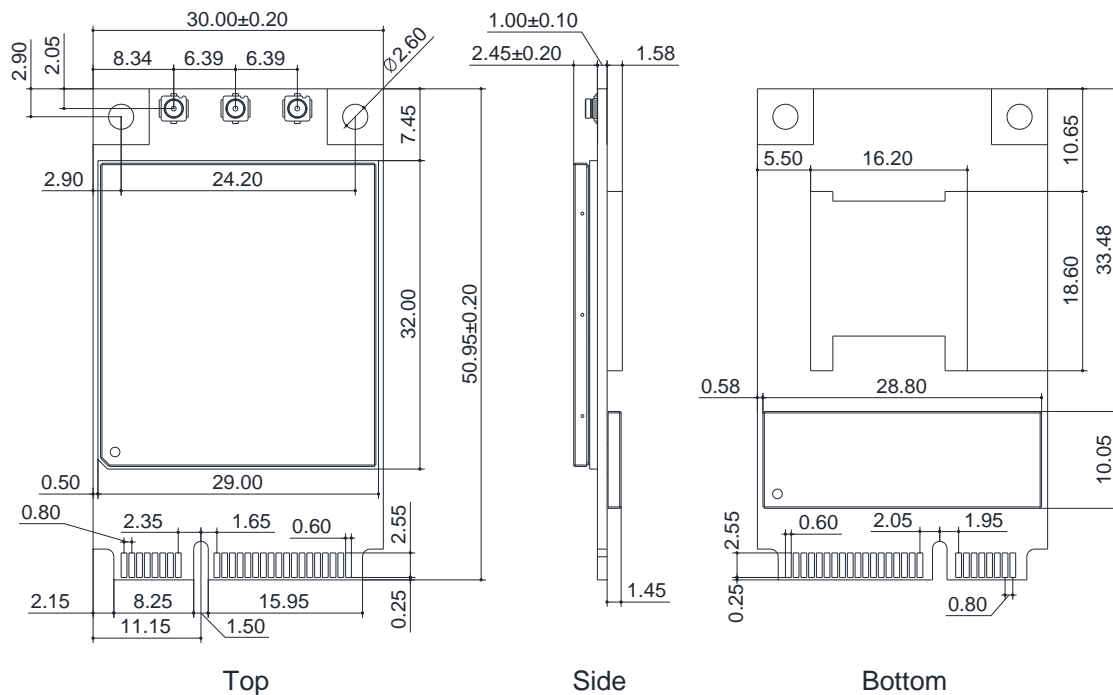

Figure 19: Mechanical Dimensions of EG25-G Mini PCIe

### NOTE

The package warpage level of the module conforms to the *JEITA ED-7306* standard.



EG25-G Mini PCIe adopts a standard Mini PCI Express connector which complies with the directives and standards listed in the **document [1]**. The following figure takes the Molex 679105700 as an example.

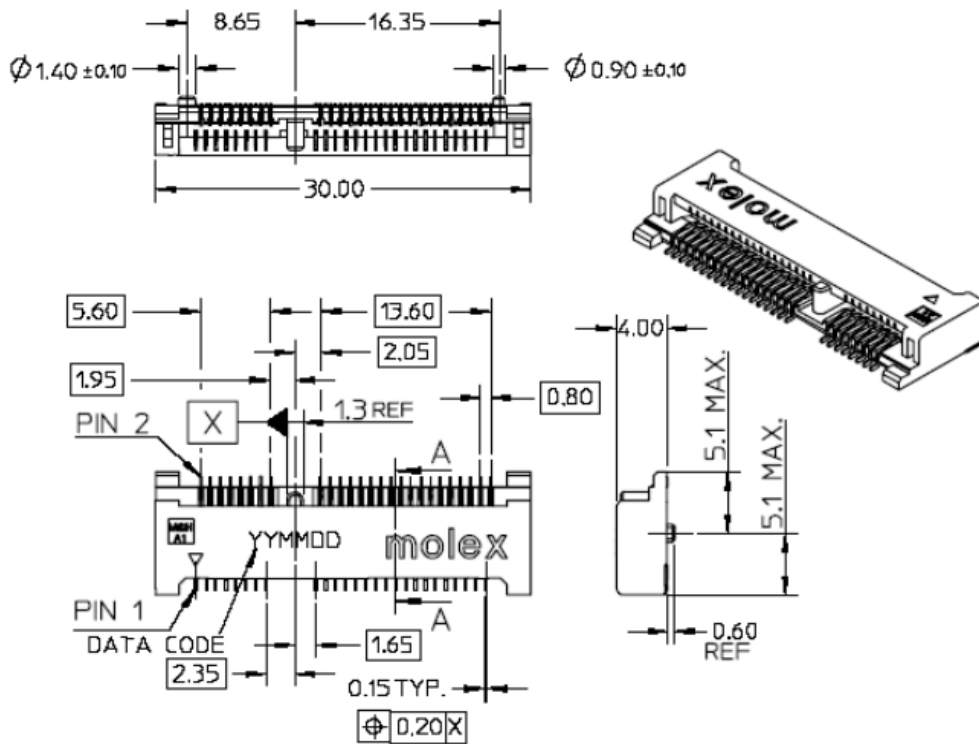

Figure 21: Dimensions of the Mini PCIe Express Connector (Molex 679105700)

## 7.4. Packaging Specifications

EG25-G Mini PCIe modules are packaged in a tray. Each tray contains 10 of modules. The smallest package of EG25-G Mini PCIe contains 100 modules.

# 8 Appendix A References

**Table 26: Related Documents**

SN	Document Name	Remark
[1]	PCI Express Mini Card Electromechanical Specification Revision 1.2	PCI Express Mini Card Electromechanical Specification
[2]	Quectel_LTE_Standard_AT_Commands_Manual	AT commands manual for EC21 series, EC25 series, EG91 series, EG95 series, EM05 series, EG25-G and EG21-G modules
[3]	Quectel_LTE_Standard_GNSS_Application_Note	GNSS application note for EC21 series, EC25 series, EG91 series, EG95 series, EM05 series, EG25-G and EG21-G modules
[4]	Quectel_LTE_Module_Thermal_Design_Guide	Thermal design guide for LTE standard, LTE-A and Automotive modules

**Table 27: Terms and Abbreviations**

Abbreviation	Description
AMR	Adaptive Multi-rate
bps	Bits Per Second
CS	Coding Scheme
CTS	Clear to Send
DFOTA	Delta Firmware Upgrade Over-The-Air
DL	Down Link
DTE	Data Terminal Equipment
DTR	Data Terminal Ready

---

EFR	Enhanced Full Rate
EMI	Electro Magnetic Interference
ESD	Electrostatic Discharge
ESR	Equivalent Series Resistance
FDD	Frequency Division Duplexing
FR	Full Rate
GLONASS	GLObalnaya Navigatsionnaya Sputnikovaya Sistema, the Russian Global Navigation Satellite System
GMSK	Gaussian Minimum Shift Keying
GNSS	Global Navigation Satellite System
GPS	Global Positioning System
GSM	Global System for Mobile Communications
HR	Half Rate
HSPA	High Speed Packet Access
HSUPA	High Speed Uplink Packet Access
kbps	Kilo Bits Per Second
LED	Light Emitting Diode
LTE	Long-Term Evolution
Mbps	Million Bits Per Second
MCU	Micro Control Unit
ME	Mobile Equipment
MIMO	Multiple-Input Multiple-Output
MMS	Multimedia Messaging Service
MO	Mobile Originated
MT	Mobile Terminated
NMEA	National Marine Electronics Association

---



---

PCM	Pulse Code Modulation
PDA	Personal Digital Assistant
PDU	Protocol Data Unit
POS	Point of Sale
PPP	Point-to-Point Protocol
RF	Radio Frequency
RTS	Ready To Send
Rx	Receive
SIMO	Single Input Multiple Output
SMS	Short Message Service
TX	Transmitting Direction
TVS	Transient Voltage Suppressor
UART	Universal Asynchronous Receiver & Transmitter
UL	Uplink
URC	Unsolicited Result Code
USB	Universal Serial Bus
(U)SIM	(Universal) Subscriber Identification Module
WCDMA	Wideband Code Division Multiple Access

---