



IEI Technology Corp.



MODEL:

**UIBX-200-R11/Z510P**

**Ultra Compact Embedded System with CompactFlash® Slot  
VGA, Gigabit Ethernet, Four USB, 802.11b/g/n Wireless,  
Line out, Mic, Two RS-232, RoHS Compliant**

## User Manual

Rev. 1.10 – 8 July 2011



# Revision

Date	Version	Changes
8 July, 2011	1.10	Update for R11 version
17 August, 2010	1.02	Added Appendix B: Watchdog Timer Added AT/ATX switch location diagram
14 January 2010	1.01	Updated embedded OS options
12 October 2009	1.00	Initial release

# Copyright

---

## **COPYRIGHT NOTICE**

The information in this document is subject to change without prior notice in order to improve reliability, design and function and does not represent a commitment on the part of the manufacturer.

In no event will the manufacturer be liable for direct, indirect, special, incidental, or consequential damages arising out of the use or inability to use the product or documentation, even if advised of the possibility of such damages.

This document contains proprietary information protected by copyright. All rights are reserved. No part of this manual may be reproduced by any mechanical, electronic, or other means in any form without prior written permission of the manufacturer.

## **TRADEMARKS**

All registered trademarks and product names mentioned herein are used for identification purposes only and may be trademarks and/or registered trademarks of their respective owners.

# Table of Contents

---

<b>1 INTRODUCTION</b> .....	<b>1</b>
1.1 OVERVIEW.....	2
1.2 BENEFITS .....	2
1.3 FEATURES.....	3
1.4 TECHNICAL SPECIFICATIONS .....	3
1.5 CERTIFICATIONS .....	4
<b>2 DETAILED SPECIFICATIONS</b> .....	<b>5</b>
2.1 FRONT PANEL.....	6
2.2 REAR CONNECTOR PANEL .....	6
2.3 DIMENSIONS.....	8
2.4 MAINTENANCE.....	9
<b>3 UNPACKING</b> .....	<b>10</b>
3.1 ANTI-STATIC PRECAUTIONS .....	11
3.2 UNPACKING PRECAUTIONS.....	11
3.3 UNPACKING CHECKLIST .....	12
3.4 OPTIONAL ITEMS .....	13
<b>4 INSTALLATION</b> .....	<b>14</b>
4.1 INSTALLATION PRECAUTIONS .....	15
4.2 JUMPER SETTINGS .....	16
4.2.1 AT/ATX Power Switch Settings .....	16
4.2.2 Clear CMOS Jumper.....	17
4.3 COMPACTFLASH® CARD INSTALLATION .....	18
4.4 SD STORAGE CARD INSTALLATION (OPTIONAL) .....	18
4.5 EXTERNAL PERIPHERAL INTERFACE CONNECTORS.....	20
4.5.1 Power Input.....	21
4.5.2 Audio Connector .....	21
4.5.3 LAN Connectors.....	22
4.5.4 Serial Port Connector.....	24

## UIBX-200-R11/Z510P Embedded System

4.5.5 USB Connector .....	25
4.5.6 VGA Connector .....	26
4.6 MOUNTING THE SYSTEM .....	28
4.6.1 Mounting Option 1 .....	28
4.6.2 Mounting Option 2 .....	30
4.7 SOFTWARE .....	32
<b>5 BIOS .....</b>	<b>34</b>
5.1 INTRODUCTION .....	35
5.1.1 Starting Setup .....	35
5.1.2 Using Setup .....	35
5.1.3 Getting Help .....	36
5.1.4 Unable to Reboot After Configuration Changes .....	36
5.1.5 BIOS Menu Bar .....	36
5.2 MAIN .....	37
5.3 ADVANCED .....	38
5.3.1 CPU Configuration .....	39
5.3.2 IDE Configuration .....	40
5.3.2.1 SATA Channel .....	41
5.3.3 Super IO Configuration .....	45
5.3.4 Hardware Health Configuration .....	46
5.3.5 Remote Access Configuration .....	47
5.3.6 USB Configuration .....	50
5.3.6.1 USB Mass Storage Device Configuration .....	51
5.4 PCI/PNP .....	53
5.5 BOOT .....	55
5.5.1 Boot Settings Configuration .....	55
5.5.2 Boot Device Priority .....	57
5.5.3 Hard Disk Drives .....	58
5.6 SECURITY .....	58
5.7 CHIPSET .....	59
5.7.1 Northbridge Configuration .....	60
5.7.2 Southbridge Configuration .....	61
5.8 EXIT .....	62
<b>A ONE KEY RECOVERY .....</b>	<b>64</b>

A.1 ONE KEY RECOVERY INTRODUCTION .....	65
A.1.1 System Requirement.....	66
A.1.2 Supported Operating System.....	67
A.2 SETUP PROCEDURE FOR WINDOWS.....	68
A.2.1 Hardware and BIOS Setup .....	68
A.2.2 Create Partitions .....	69
A.2.3 Install Operating System, Drivers and Applications.....	72
A.2.4 Build-up Recovery Partition.....	73
A.2.5 Create Factory Default Image.....	75
A.3 SETUP PROCEDURE FOR LINUX.....	80
A.4 RECOVERY TOOL FUNCTIONS .....	83
A.4.1 Factory Restore .....	85
A.4.2 Backup System.....	86
A.4.3 Restore Your Last Backup.....	87
A.4.4 Manual.....	88
A.5 OTHER INFORMATION .....	89
A.5.1 Using AHCI Mode or ALi M5283 / VIA VT6421A Controller.....	89
A.5.2 System Memory Requirement .....	91
<b>B SAFETY PRECAUTIONS.....</b>	<b>92</b>
B.1 SAFETY PRECAUTIONS.....	93
B.1.1 General Safety Precautions.....	93
B.1.2 Anti-static Precautions .....	94
B.1.3 Product Disposal.....	95
B.2 MAINTENANCE AND CLEANING PRECAUTIONS .....	95
B.2.1 Maintenance and Cleaning.....	95
B.2.2 Cleaning Tools.....	96
<b>C WATCHDOG TIMER.....</b>	<b>97</b>
<b>D HAZARDOUS MATERIALS DISCLOSURE .....</b>	<b>100</b>
D.1 HAZARDOUS MATERIALS DISCLOSURE TABLE FOR IPB PRODUCTS CERTIFIED AS ROHS COMPLIANT UNDER 2002/95/EC WITHOUT MERCURY .....	101

# List of Figures

Figure 1-1: UIBX-200-R11/Z510P .....	2
Figure 2-1: Front Panel .....	6
Figure 2-2: UIBX-200-R11/Z510P Peripheral Connectors .....	7
Figure 2-3: Physical Dimensions (millimeters).....	8
Figure 4-1: AT/ATX Switch Location (Front Panel) .....	17
Figure 4-2: CompactFlash® Card Installation .....	18
Figure 4-3: Bottom Cover Removal .....	19
Figure 4-4: SD Card Slots .....	19
Figure 4-5: Peripheral Connectors (Rear) .....	20
Figure 4-6: Peripheral Connectors (Front) .....	21
Figure 4-7: Power Terminal Block.....	21
Figure 4-8: Audio Connector .....	22
Figure 4-9: LAN Connection .....	23
Figure 4-10: RJ-45 Ethernet Connector.....	23
Figure 4-11: Serial Device Connector.....	24
Figure 4-12: Serial Port Pinouts .....	25
Figure 4-13: USB Device Connection .....	26
Figure 4-14: VGA Connector .....	27
Figure 4-15: VGA Connector .....	27
Figure 4-16: 100 mm to 75 mm Adapter .....	28
Figure 4-17: Attachment Installation.....	29
Figure 4-18: System Attachment Screws .....	29
Figure 4-19: Mounting Screws.....	30
Figure 4-20: 100 mm to 75 mm Adapter .....	31
Figure 4-21: Attachment Installation.....	31
Figure 4-22: System Attachment Screws .....	32
Figure 4-23: Slide Panel PC onto UIBX-200-R11/Z510P .....	32
Figure A-1: IEI One Key Recovery Tool Menu .....	65
Figure A-2: Launching the Recovery Tool .....	69
Figure A-3: Recovery Tool Setup Menu .....	70

Figure A-4: Command Mode.....	70
Figure A-5: Partition Creation Commands.....	71
Figure A-6: Launching the Recovery Tool .....	73
Figure A-7: System Configuration for Windows .....	73
Figure A-8: Build-up Recovery Partition .....	74
Figure A-9: Press any key to continue .....	74
Figure A-10: Press F3 to Boot into Recovery Mode.....	75
Figure A-11: Recovery Tool Menu .....	75
Figure A-12: About Symantec Ghost Window.....	76
Figure A-13: Symantec Ghost Path .....	76
Figure A-14: Select a Local Source Drive .....	77
Figure A-15: Select a Source Partition from Basic Drive .....	77
Figure A-16: File Name to Copy Image to .....	78
Figure A-17: Compress Image.....	78
Figure A-18: Image Creation Confirmation .....	79
Figure A-19: Image Creation Process.....	79
Figure A-20: Image Creation Complete .....	79
Figure A-21: Press Any Key to Continue .....	80
Figure A-22: Partitions for Linux.....	81
Figure A-23: System Configuration for Linux.....	82
Figure A-24: Access menu.lst in Linux (Text Mode).....	82
Figure A-25: Recovery Tool Menu .....	83
Figure A-26: Recovery Tool Main Menu .....	84
Figure A-27: Restore Factory Default.....	85
Figure A-28: Recovery Complete Window .....	85
Figure A-29: Backup System.....	86
Figure A-30: System Backup Complete Window .....	86
Figure A-31: Restore Backup .....	87
Figure A-32: Restore System Backup Complete Window .....	87
Figure A-33: Symantec Ghost Window .....	88



# List of Tables

---

Table 1-1: Technical Specifications.....	4
Table 3-1: Package List Contents .....	12
Table 3-2: Optional Items .....	13
Table 4-1: Jumpers .....	16
Table 4-2: AT/ATX Power Switch Settings .....	17
Table 4-3: Clear BIOS Jumper Settings.....	17
Table 4-4: LAN Pinouts .....	23
Table 4-5: RJ-45 Ethernet Connector LEDs .....	24
Table 4-6: Serial Port Pinouts.....	25
Table 4-7: USB Port Pinouts.....	26
Table 4-8: VGA Connector Pinouts.....	28
Table 5-1: BIOS Navigation Keys .....	36



Chapter

1

# Introduction

---

## 1.1 Overview



Figure 1-1: UIBX-200-R11/Z510P

The UIBX-200-R11/Z510P embedded system is an ultra small PC for installation between a computer screen and its stand. It is powered by the Intel® Atom™ Z530P/Z510P processor, uses the Intel® US15WP system chip and has 1.0 GB of DDR2 memory.

The Intel® US15WP system chip provides many built-in graphics functions allowing high quality video playback without the need for expensive hardware.

The UIBX-200-R11/Z510P is best when combined with the optional CompactFlash® card with Microsoft® Windows XP Embedded preinstalled. A software development kit and documentation are also available to help easily customize the operating system according to the installation requirements.

## 1.2 Benefits

Some of the UIBX-200-R11/Z510P benefits include:

- Customizable operating system to suit application needs.
- Less downtime from overheating because there are not fans to fail
- Cost savings with low power consumption
- Easy installation on standard VESA mounting
- Both wired and wireless network connectivity

## UIBX-200-R11/Z510P Embedded System

### 1.3 Features

The UIBX-200-R11/Z510P features are listed below:

- Intel® Atom™ Z530P/Z510P processor
- 1.0 GB of DDR2
- VGA video output
- One Gigabit Ethernet port
- Four USB 2.0 ports
- Two RS-232 serial ports
- RoHS compliant

### 1.4 Technical Specifications

The UIBX-200-R11/Z510P technical specifications are listed in Table 1-1.

Specifications	
<b>System</b>	
<b>CPU</b>	Intel® Atom™ Z530P/Z510P processor
<b>System Chipset</b>	Intel® US15WP
<b>Memory</b>	1.0 GB of DDR2 memory
<b>Real-time Clock</b>	Battery backup RTC
<b>Watchdog Timer</b>	Software programmable supports 1~255 sec. system reset
<b>Reset</b>	Reset button
<b>Display</b>	
<b>Video Output</b>	VGA
<b>Video Support</b>	Intel® Graphics Media Accelerator 500 (GMA500) VGA through Chrontel CH7317A
<b>I/O and Communications</b>	
<b>Ethernet</b>	1 x 10/100/1000 Mb/s 1 x 802.11b/g/n (W model only)
<b>Serial Ports</b>	2 x RS-232

Specifications	
<b>USB Interfaces</b>	4 x USB 2.0 host connectors
<b>Audio</b>	Line out Microphone in
Power	
<b>Power Supply</b>	5 VDC
<b>Power Consumption</b>	9.5 W
Environmental and Mechanical	
<b>Operating Temperature</b>	0°C~50°C
<b>Humidity</b>	5%RH to 90%RH (non-condensing)
<b>Vibration</b>	Operating Random Vibration Mode (MIL-STD-810F 514.5C-3) 1.Axes: 3 axs (Vertical / Transverse / Longitudinal). 2.10-500 Hz, 60min/axis. 3.Equivalent to Z:2.18 Grms X:1.6 Grms Y:1.96 Grms
<b>Color</b>	Black front, sides and bottom. Light gray top and back
<b>Physical Dimensions</b>	120 mm x 44.4 mm x 125 mm

**Table 1-1: Technical Specifications**

## 1.5 Certifications

All UIBX-200-R11/Z510P series models comply with the following international standards:

- RoHS
- CE, FCC Class A, CCC, UL

For a more detailed description of these standards, please refer to **Appendix A**.

Chapter

2

# Detailed Specifications

---

## 2.1 Front Panel

The front panel consists of a small door, giving access to the CompactFlash® card, and also has two USB ports, an audio output and microphone input jack.

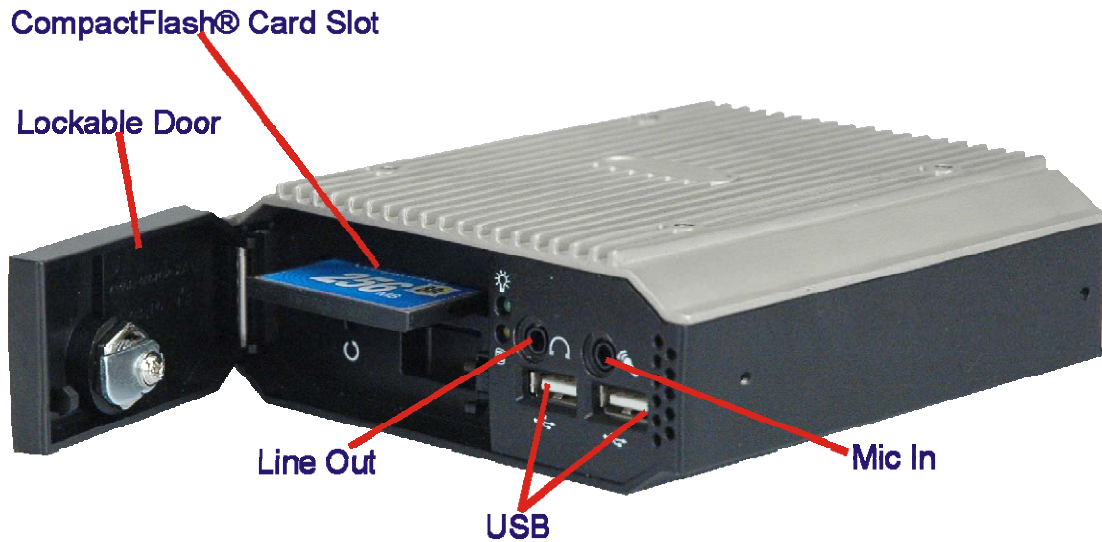

**Figure 2-1: Front Panel**

Connectors and buttons on the front panel include the following.

- 1 x CompactFlash® slot
- 2 x USB connectors
- 1 x Microphone input
- 1 x Line output
- 1 x AT/ATX switch
- 1 x Reset button

## 2.2 Rear Connector Panel

All external peripheral interface connectors are located on the bottom panel of the UIBX-200-R11/Z510P . The peripheral interface connectors are shown in Figure 2-2.



## UIBX-200-R11/Z510P Embedded System

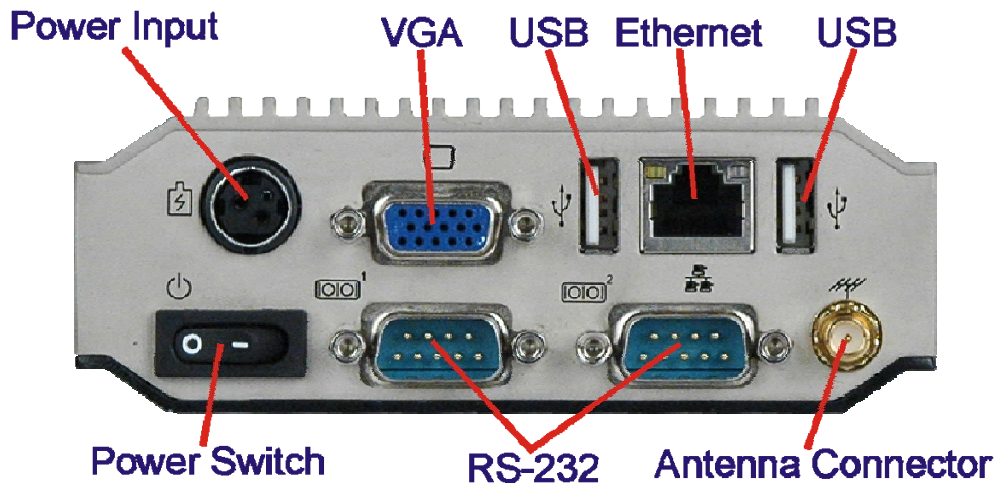

**Figure 2-2: UIBX-200-R11/Z510P Peripheral Connectors**

Connectors and buttons on the rear panel include the following.

- 1 x 5 V DC power input
- 1 x Power switch
- 1 x VGA output
- 2 x RS-232 ports
- 2 x USB ports
- 1 x Gigabit Ethernet port
- 1 x Antenna connector (W model only)

### 2.3 Dimensions

The physical dimensions are shown and listed below:

- Width: 120 mm
- Height: 44.4 mm
- Depth: 125 mm

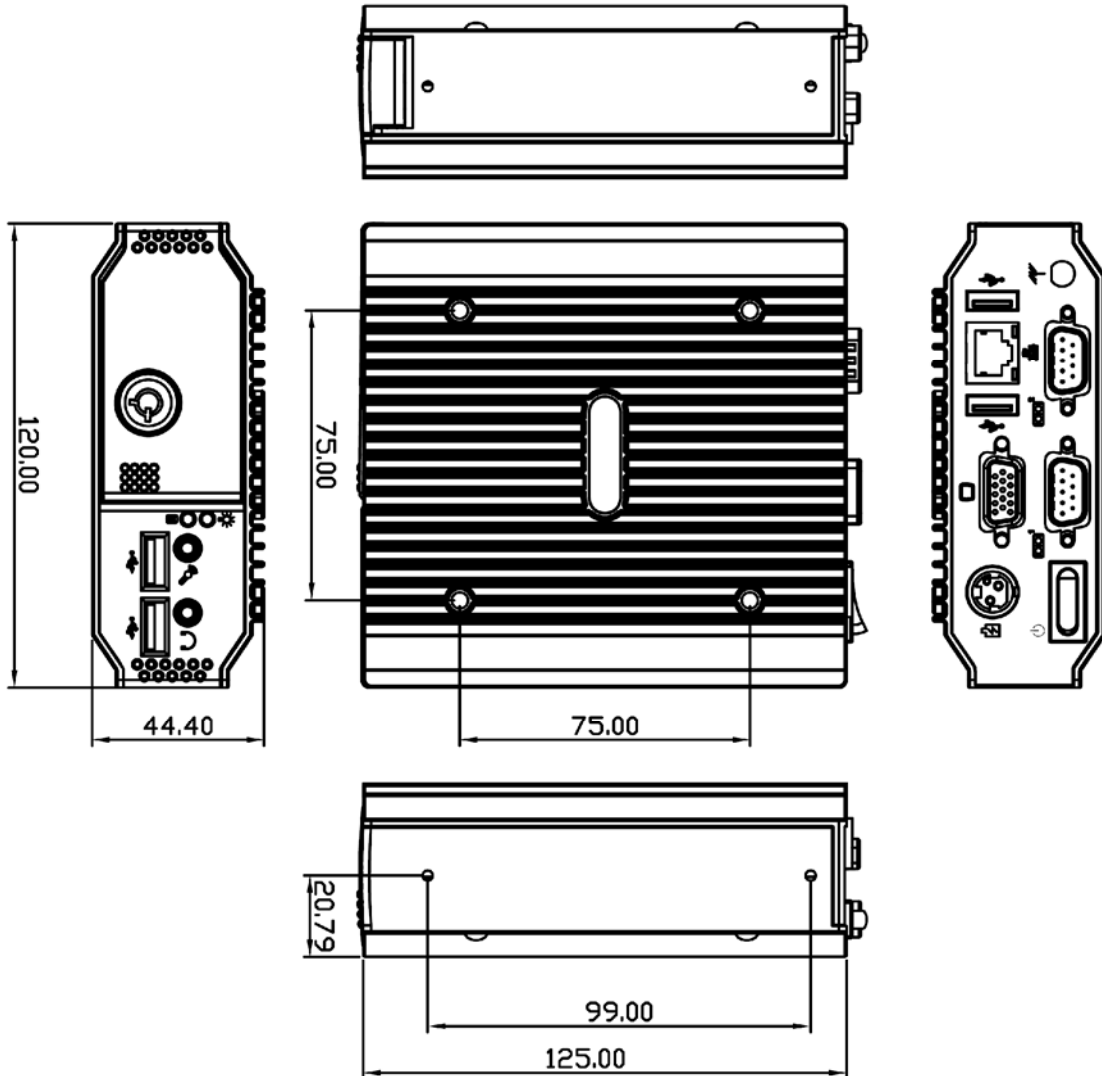

Figure 2-3: Physical Dimensions (millimeters)

## UIBX-200-R11/Z510P Embedded System

### 2.4 Maintenance

Don't open the UIBX-200-R11/Z510P (except the CompactFlash® door), there are no user-serviceable parts inside.



Chapter

3

# Unpacking

---

### 3.1 Anti-static Precautions

---

**WARNING:**

Failure to take ESD precautions during installation may result in permanent damage to the UIBX-200-R11/Z510P and severe injury to the user.

---

Electrostatic discharge (ESD) can cause serious damage to electronic components, including the UIBX-200-R11/Z510P. Dry climates are especially susceptible to ESD. It is therefore critical that whenever the UIBX-200-R11/Z510P or any other electrical component is handled, the following anti-static precautions are strictly adhered to.

- ***Wear an anti-static wristband:*** Wearing a simple anti-static wristband can help to prevent ESD from damaging the board.
- ***Self-grounding:*** Before handling the board touch any grounded conducting material. During the time the board is handled, frequently touch any conducting materials that are connected to the ground.
- ***Use an anti-static pad:*** When configuring the UIBX-200-R11/Z510P, place it on an anti-static pad. This reduces the possibility of ESD damaging the UIBX-200-R11/Z510P.

### 3.2 Unpacking Precautions

When the UIBX-200-R11/Z510P is unpacked, please do the following:





- Follow the anti-static precautions outlined in **Section 3.1**.
- Make sure the packing box is facing upwards so the UIBX-200-R11/Z510P does not fall out of the box.
- Make sure all the components shown in **Section 3.3** are present.

### 3.3 Unpacking Checklist

**NOTE:**



If some of the components listed in the checklist below are missing, please do not proceed with the installation. Contact the IEI reseller or vendor you purchased the UIBX-200-R11/Z510P from or contact an IEI sales representative directly. To contact an IEI sales representative, please send an email to [sales@iei.com.tw](mailto:sales@iei.com.tw).

The UIBX-200-R11/Z510P is shipped with the following components:

Quantity	Item and Part Number	Image
1	UIBX-200-R11/Z510P	
1	Power adapter	
1	Screw set	
1	Quick installation guide	
1	Driver CD	

**Table 3-1: Package List Contents**

### 3.4 Optional Items

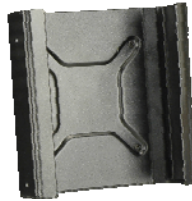
Quantity	Item	Image
	uIBXCF-US15WP-XPE Windows XP Embedded OS on 1 GB CompactFlash® card	
	uIBXCF-US15WP-CE060 Windows CE 6.0 Embedded OS on 128 MB CompactFlash® card	
	VX-75100B 75 mm to 100 mm VESA adapter. For fitting uIBXVK-200B on devices 100 mm VESA mounting pattern.	
	uIBXVK-200B Double side VESA mount kit for uIBX-200, black. Fits 75 mm VESA mounting pattern.	

**Table 3-2: Optional Items**

Chapter

4

# Installation

---



### 4.1 Installation Precautions

During installation, be aware of the precautions below:

- **Read the user manual:** The user manual provides a complete description of the UIBX-200-R11/Z510P, installation instructions and configuration options.
- **DANGER! Disconnect Power:** Power to the UIBX-200-R11/Z510P must be disconnected during the installation process, or before any attempt is made to access the rear panel. Electric shock and personal injury might occur if the rear panel of the UIBX-200-R11/Z510P is opened while the power cord is still connected to an electrical outlet.
- **Qualified Personnel:** The UIBX-200-R11/Z510P must be installed and operated only by trained and qualified personnel. Maintenance, upgrades, or repairs may only be carried out by qualified personnel who are familiar with the associated dangers.
- **Air Circulation:** Make sure there is sufficient air circulation when installing the UIBX-200-R11/Z510P. The UIBX-200-R11/Z510P's cooling vents must not be obstructed by any objects. Blocking the vents can cause overheating of the UIBX-200-R11/Z510P. Leave at least 5 cm of clearance around the UIBX-200-R11/Z510P to prevent overheating.
- **Grounding:** The UIBX-200-R11/Z510P should be properly grounded. The voltage feeds must not be overloaded. Adjust the cabling and provide external overcharge protection per the electrical values indicated on the label attached to the back of the UIBX-200-R11/Z510P.

## 4.2 Jumper Settings



### NOTE:

A jumper is a metal bridge used to close an electrical circuit. It consists of two or three metal pins and a small metal clip (often protected by a plastic cover) that slides over the pins to connect them. To CLOSE/SHORT a jumper means connecting the pins of the jumper with the plastic clip and to OPEN a jumper means removing the plastic clip from a jumper.

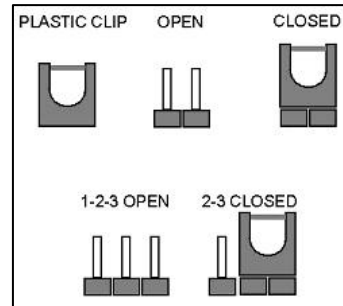

The hardware jumpers must be set before installation. Jumpers are shown in Table 4-1.

Description	Label	Type
AT/ATX power select	SW1	Switch
Clear CMOS	JP1	3-pin header

**Table 4-1: Jumpers**

### 4.2.1 AT/ATX Power Switch Settings

<b>Jumper Label:</b>	<b>SW1</b>
<b>Jumper Type:</b>	Switch
<b>Jumper Settings:</b>	See <b>Table 4-2</b>
<b>Jumper Location</b>	See <b>Figure 4-1</b>

Sets the system power as AT or ATX.

## UIBX-200-R11/Z510P Embedded System

Switch Position	Description
Right	Use ATX power (Default)
Left	Use AT power

**Table 4-2: AT/ATX Power Switch Settings**

The AT/ATX switch is located below the CF card slot on the front panel as shown in **Figure 4-1**.

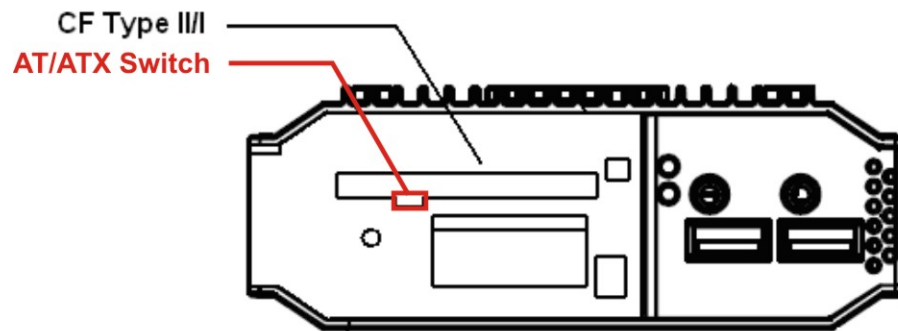

**Figure 4-1: AT/ATX Switch Location (Front Panel)**

### 4.2.2 Clear CMOS Jumper

<b>Jumper Label:</b>	<b>JP1</b>
<b>Jumper Type:</b>	3-pin header
<b>Jumper Settings:</b>	See <b>Table 4-3</b>

To reset the BIOS, move the jumper to the "Clear BIOS" position for 3 seconds or more, then move back to the default position.

Setting	Description
1-2	Keep current BIOS setup
2-3	Clear BIOS

**Table 4-3: Clear BIOS Jumper Settings**

### 4.3 CompactFlash® Card Installation

The UIBX-200-R11/Z510P supports a single CompactFlash® card. The CompactFlash® card contains the operating system. To install, follow the steps below.

**Step 1:** Unlock and open the cover door.

**Step 2:** Slide the CompactFlash® card into the slot.

**Step 3:** Close and lock the door.

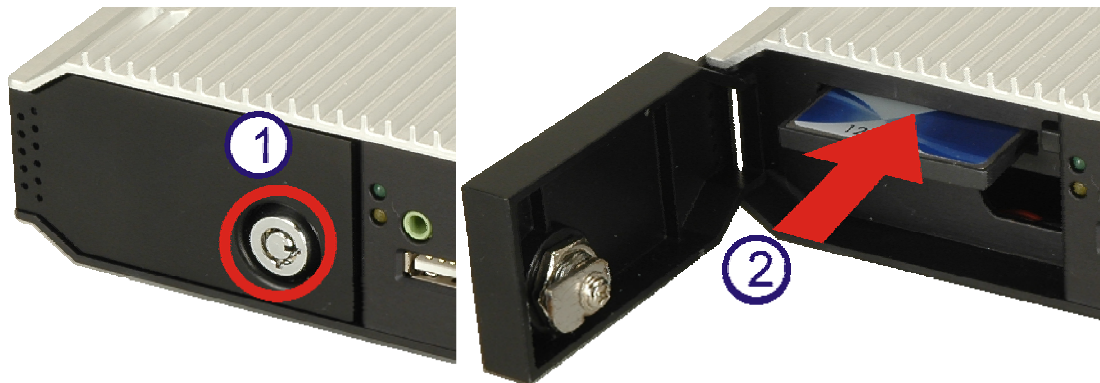

Figure 4-2: CompactFlash® Card Installation

### 4.4 SD Storage Card Installation (Optional)

An optional two SD card slots are available inside the UIBX-200-R11/Z510P. The SD cards are used for storage only. The CompactFlash® card is used for the operating system. To install SD cards in the UIBX-200-R11/Z510P, please follow the steps below.

**Step 1:** Turn the system upside down.

**Step 2:** Remove the screws.

**Step 3:** Slide back and lift to remove.

# UIBX-200-R11/Z510P Embedded System

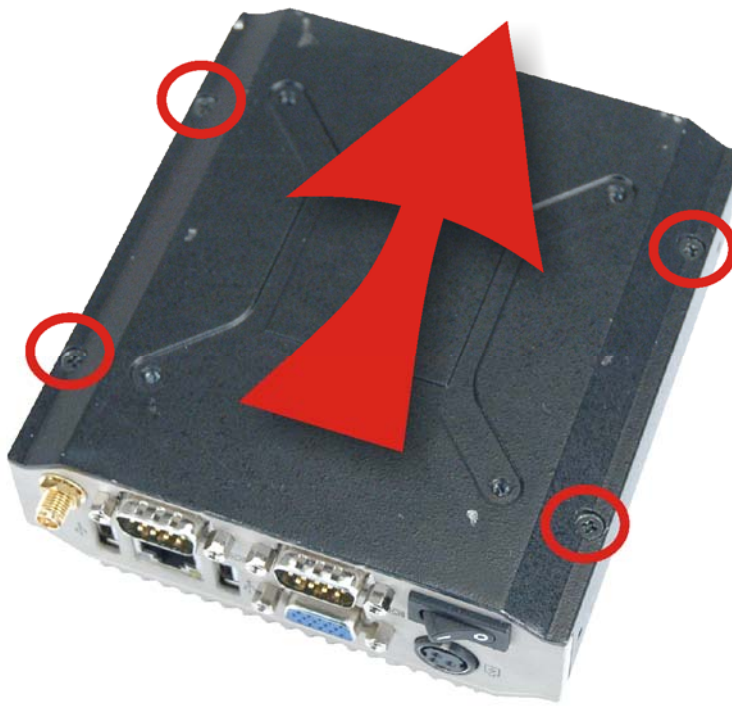

Figure 4-3: Bottom Cover Removal

**Step 4:** Insert the SD cards into the slots indicated.

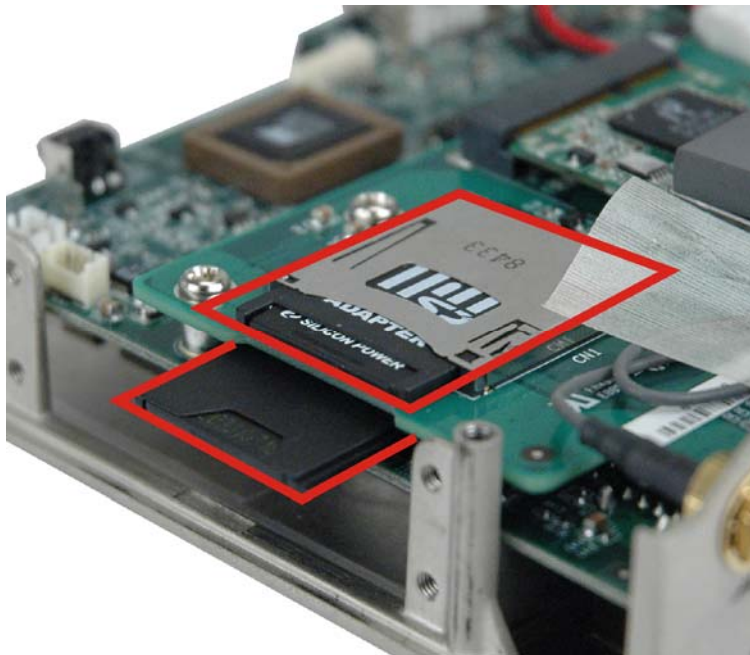

Figure 4-4: SD Card Slots

## 4.5 External Peripheral Interface Connectors

The UIBX-200-R11/Z510P has the following connectors. Detailed descriptions of the connectors can be found in the subsections below.

- Power input
- VGA
- USB
- Ethernet
- RS-232
- Antenna connector
- Line out
- Mic

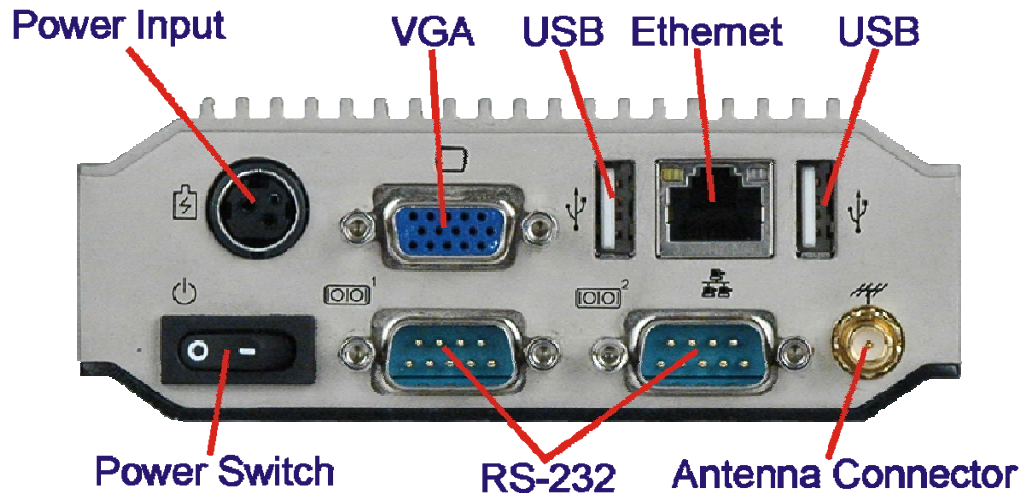

Figure 4-5: Peripheral Connectors (Rear)

## UIBX-200-R11/Z510P Embedded System

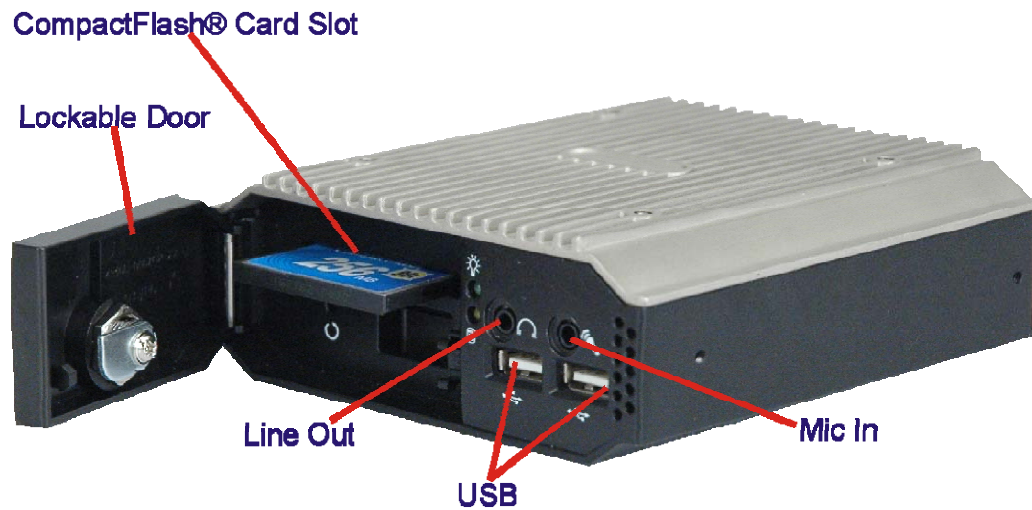

Figure 4-6: Peripheral Connectors (Front)

### 4.5.1 Power Input

The power terminal block connects to the included 5 V DC power adapter.

<b>CN Label:</b>	<b>Power Input</b>
<b>CN Type:</b>	Terminal block
<b>CN Location:</b>	See Figure 4-5
<b>CN Pinouts:</b>	See Figure 4-7

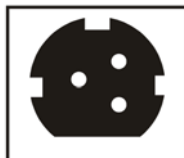

Figure 4-7: Power Terminal Block

### 4.5.2 Audio Connector

<b>CN Label:</b>	<b>Line out, Mic</b>
<b>CN Type:</b>	Audio jacks
<b>CN Location:</b>	See Figure 4-6

The audio jacks connect to external audio devices.

- **Line Out port (Lime):** Connects to a headphone or a speaker. With multi-channel configurations, this port can also connect to front speakers.
- **Microphone (Pink):** Connects a microphone.



Figure 4-8: Audio Connector

### 4.5.3 LAN Connectors

<b>CN Label:</b>	LAN
<b>CN Type:</b>	RJ-45
<b>CN Location:</b>	See Figure 4-5
<b>CN Pinouts:</b>	See Table 4-4

The LAN connectors allow connection to an external network.

**Step 1: Locate the RJ-45 connectors.** The locations of the USB connectors are shown in **Chapter 4**.

**Step 2: Align the connectors.** Align the RJ-45 connector on the LAN cable with one of the RJ-45 connectors on the UIBX-200-R11/Z510P. See Figure 4-9.



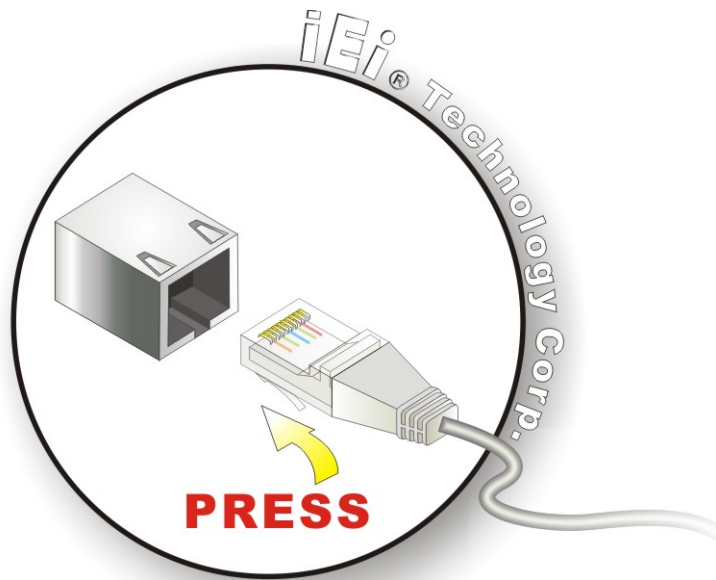

Figure 4-9: LAN Connection

**Step 3:** Insert the LAN cable RJ-45 connector. Once aligned, gently insert the LAN cable RJ-45 connector into the on-board RJ-45 connector.

Pin	Description	Pin	Description
1	TXA+	5	TXC-
2	TXA-	6	TXB-
3	TXB+	7	TXD+
4	TXC+	8	TXD-

Table 4-4: LAN Pinouts

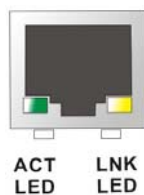

Figure 4-10: RJ-45 Ethernet Connector

The RJ-45 Ethernet connector has two status LEDs, one green and one yellow. The green LED indicates activity on the port and the yellow LED indicates the port is linked. See Table 4-5.

STATUS	DESCRIPTION	STATUS	DESCRIPTION
GREEN	Activity	YELLOW	Linked

**Table 4-5: RJ-45 Ethernet Connector LEDs**

#### 4.5.4 Serial Port Connector

- CN Label:** RS-232
- CN Type:** DB-9 connectors
- CN Location:** See Figure 4-5
- CN Pinouts:** See Table 4-6 and Figure 4-12

RS-232 serial port devices can be attached to the DB-9 ports on the rear panel.

**Step 1:** **Locate the DB-9 connector.** The location of the DB-9 connector is shown in Chapter 3.

**Step 2:** **Insert the serial connector.** Insert the DB-9 connector of a serial device into the DB-9 connector on the external peripheral interface. See Figure 4-11.

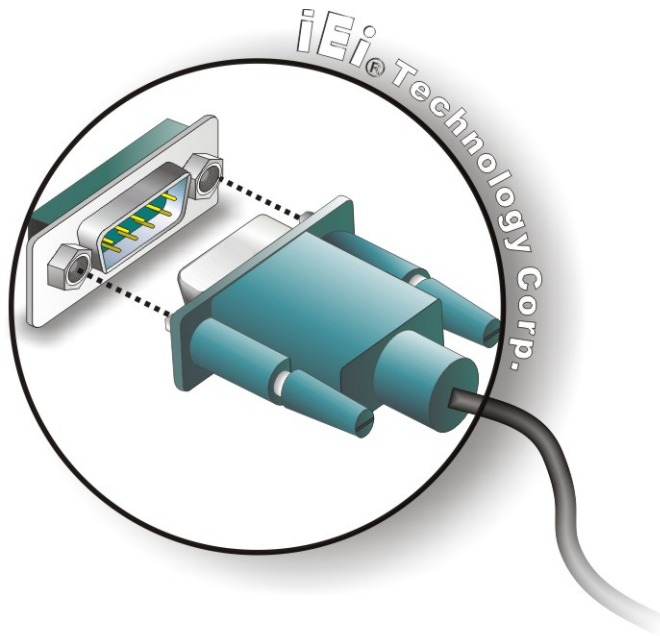

**Figure 4-11: Serial Device Connector**

## UIBX-200-R11/Z510P Embedded System

**Step 3:** **Secure the connector.** Secure the serial device connector to the external interface by tightening the two retention screws on either side of the connector.

Pin	Description	Pin	Description
1	DCD	6	DSR
2	RX	7	RTS
3	TX	8	CTS
4	DTR	9	RI
5	GND		

**Table 4-6: Serial Port Pinouts**

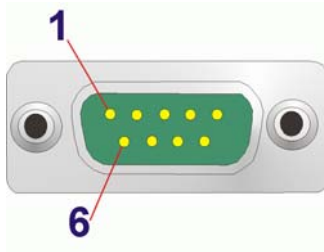

**Figure 4-12: Serial Port Pinouts**

### 4.5.5 USB Connector

<b>CN Label:</b>	<b>USB</b>
<b>CN Type:</b>	USB port
<b>CN Location:</b>	See Figure 4-5 and Figure 4-6
<b>CN Pinouts:</b>	See Table 4-7

The USB ports are for attaching USB peripheral devices to the system.

**Step 1:** **Located the USB connectors.** The locations of the USB connectors are shown in **Chapter 4**.

**Step 2:** **Align the connectors.** Align the USB device connector with one of the connectors. See Figure 4-13.

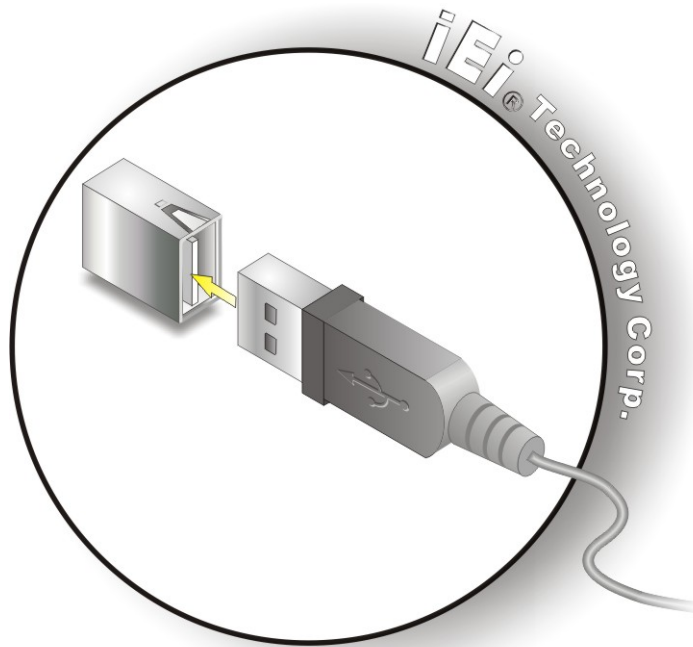

**Figure 4-13: USB Device Connection**

**Step 3:** Insert the device connector. Once aligned, gently insert the USB device connector into the on-board connector.

Pin	Description	Pin	Description
1	USBV3L 5 V	2	GND
3	USBP4N	4	USBP5P
5	USBP4P	6	USBP5N
7	GND	8	USBV3L 5 V

**Table 4-7: USB Port Pinouts**

### 4.5.6 VGA Connector

- CN Label:** VGA
- CN Type:** 15-pin Female
- CN Location:** See Figure 4-5
- CN Pinouts:** See Figure 4-15 and Table 4-8

The VGA connector connects to a monitor that accepts VGA video input.

## UIBX-200-R11/Z510P Embedded System

- Step 1:** Locate the female DB-15 connector. The location of the female DB-15 connector is shown in **Chapter 3**.
- Step 2:** Align the VGA connector. Align the male DB-15 connector on the VGA screen cable with the female DB-15 connector on the external peripheral interface.
- Step 3:** Insert the VGA connector. Once the connectors are properly aligned with the insert the male connector from the VGA screen into the female connector on the UIBX-200-R11/Z510P. See Figure 4-14.

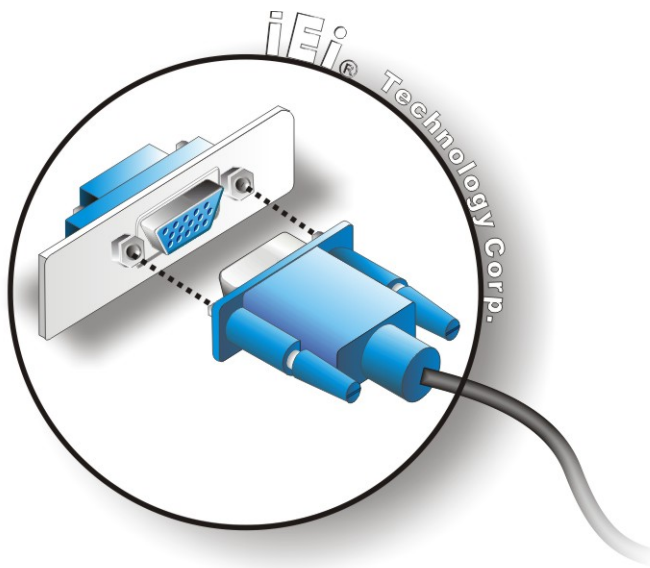

Figure 4-14: VGA Connector

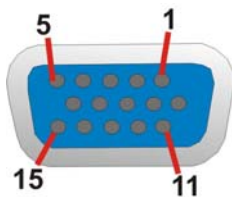

Figure 4-15: VGA Connector

Pin	Description	Pin	Description
1	RED	2	GREEN
3	BLUE	4	NC
5	GND	6	GND

Pin	Description	Pin	Description
7	GND	8	GND
9	VCC / NC	10	GND
11	NC	12	DDC DAT
13	HSYNC	14	VSYNC
15	DDCCLK		

**Table 4-8: VGA Connector Pinouts**

## 4.6 Mounting the System

To install the UIBX-200-R11/Z510P on the VESA mounting slot, between the monitor stand and the monitor, follow the instructions below.

### 4.6.1 Mounting Option 1

**Step 1:** If the mounting pattern on the panel PC is VESA 100 mm then the adapter must be attached.

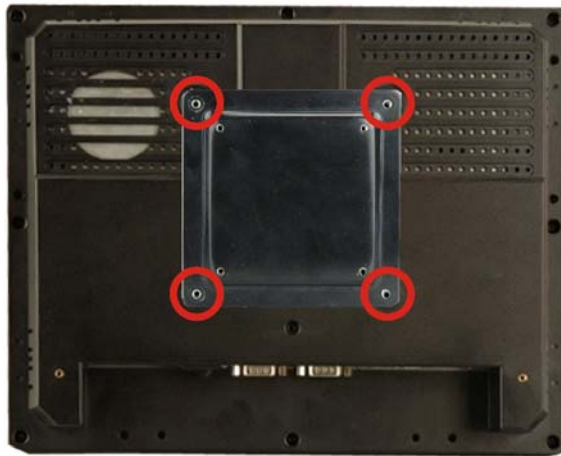

**Figure 4-16: 100 mm to 75 mm Adapter**

## UIBX-200-R11/Z510P Embedded System

**Step 2:** Fasten the attachment onto the VESA mounting on the back of the monitor.

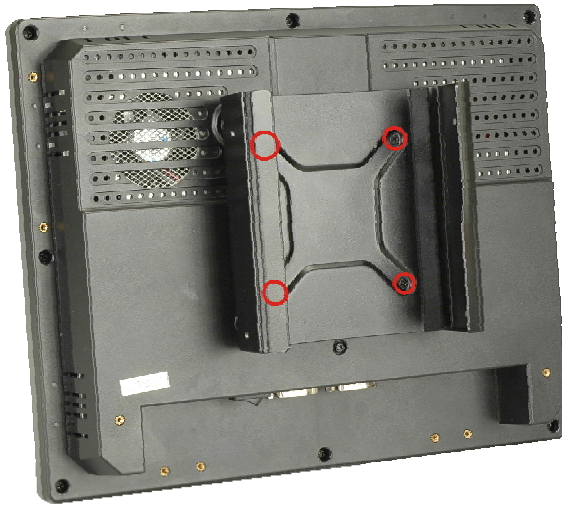

**Figure 4-17: Attachment Installation**

**Step 3:** Slide the UIBX-200-R11/Z510P into the attachment and fasten the four screws indicated.



**Figure 4-18: System Attachment Screws**

**Step 4:** Attach the monitor and UIBX-200-R11/Z510P to a stand using the VESA mounting holes on the UIBX-200-R11/Z510P.

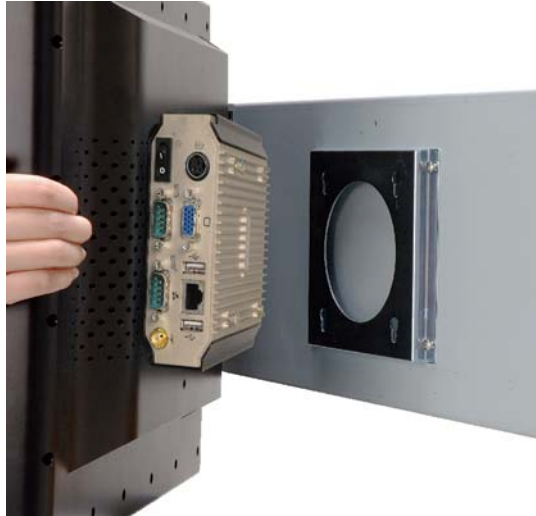

**Figure 4-19: Mounting Screws**

Three common methods of mounting the UIBX-200-R11/Z510P are listed in the subsections below.

#### **4.6.2 Mounting Option 2**

To install the UIBX-200-R11/Z510P on the VESA mounting slot, between the monitor stand and the monitor, follow the instructions below.



## UIBX-200-R11/Z510P Embedded System

**Step 1:** If the mounting pattern on the panel PC is VESA 100 mm then the adapter must be attached.

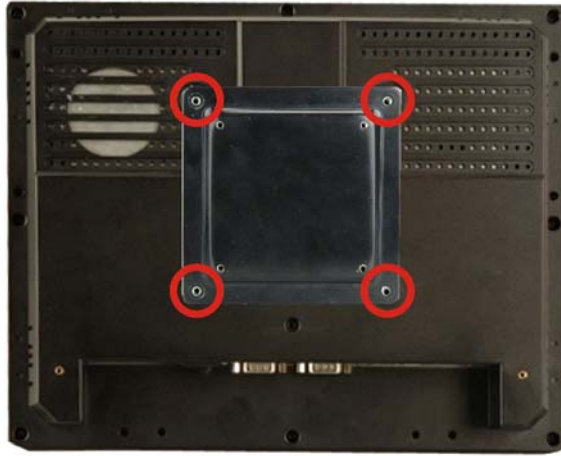

Figure 4-20: 100 mm to 75 mm Adapter

**Step 2:** Fasten the attachment onto the VESA mounting on the back of the monitor.



Figure 4-21: Attachment Installation

**Step 3:** Attach the UIBX-200-R11/Z510P to the stand.



**Figure 4-22: System Attachment Screws**

**Step 4:** Attach the panel PC to the UIBX-200-R11/Z510P. Fasten the screws on the attachment to the UIBX-200-R11/Z510P.



**Figure 4-23: Slide Panel PC onto UIBX-200-R11/Z510P**

## 4.7 Software

Optional CompactFlash® cards with either Windows CE 6.0 or XPE pre-installed are available for this system. Software application development kits are also available. For information about configuring the operating system, adding remote management tools or

## UIBX-200-R11/Z510P Embedded System

additional software and drivers, refer to the utility CD. The UIBX-200-R11/Z510P includes the following software:

- Optional Board Support Package (BSP) for customers to customize their own OS image.
- Attached Software Development Kit (SDK) for embedded Visual C++ to program Windows CE application.
- Built-in .NET Compact Framework support with related SDK
- Thin Client Technology, Microsoft RDP (Remote Desktop Protocol), to enable UIBX-200-R11/Z510P to access Microsoft Windows® based applications installed on Microsoft Terminal Service server.
- Free pre-installed utilities for configuring and diagnosing your UIBX-200-R11/Z510P.
- Free remote management tools installed in laptop for remotely configuring, monitoring, and managing your UIBX-200-R11/Z510P.



Chapter

5

**BIOS**

---

## 5.1 Introduction

The BIOS is programmed onto the BIOS chip. The BIOS setup program allows changes to certain system settings. This chapter outlines the options that can be changed.

### 5.1.1 Starting Setup

The AMI BIOS is activated when the computer is turned on. The setup program can be activated in one of two ways.

1. Press the **DELETE** key as soon as the system is turned on or
2. Press the **DELETE** key when the “**Press Del to enter SETUP**” message appears on the screen.

If the message disappears before the **DELETE** key is pressed, restart the computer and try again.

### 5.1.2 Using Setup

Use the arrow keys to highlight items, press **ENTER** to select, use the PageUp and PageDown keys to change entries, press **F1** for help and press **Esc** to quit. Navigation keys are shown in.

Key	Function
Up arrow	Move to previous item
Down arrow	Move to next item
Left arrow	Move to the item on the left hand side
Right arrow	Move to the item on the right hand side
Esc key	Main Menu – Quit and not save changes into CMOS Status Page Setup Menu and Option Page Setup Menu -- Exit current page and return to Main Menu
Page Up key	Increase the numeric value or make changes
Page Dn key	Decrease the numeric value or make changes
F1 key	General help, only for Status Page Setup Menu and Option Page Setup Menu

Key	Function
F2 /F3 key	Change color from total three colors. F2 to select color forward.
F10 key	Save all the CMOS changes, only for Main Menu

**Table 5-1: BIOS Navigation Keys**

### 5.1.3 Getting Help

When **F1** is pressed a small help window describing the appropriate keys to use and the possible selections for the highlighted item appears. To exit the Help Window press **Esc** or the **F1** key again.

### 5.1.4 Unable to Reboot After Configuration Changes

If the computer cannot boot after changes to the system configuration is made, CMOS defaults. Use the jumper described in Chapter 5.

### 5.1.5 BIOS Menu Bar

The **menu bar** on top of the BIOS screen has the following main items:

- Main – Changes the basic system configuration.
- Advanced – Changes the advanced system settings.
- PCIPnP – Changes the advanced PCI/PnP Settings
- Boot – Changes the system boot configuration.
- Security – Sets User and Supervisor Passwords.
- Chipset – Changes the chipset settings.
- Power – Changes power management settings.
- Exit – Selects exit options and loads default settings

The following sections completely describe the configuration options found in the menu items at the top of the BIOS screen and listed above.

## 5.2 Main

The **Main** BIOS menu (BIOS Menu 1) appears when the **BIOS Setup** program is entered. The **Main** menu gives an overview of the basic system information.

```

BIOS SETUP UTILITY
Main  Advanced  PCIPNP  Boot  Security  Chipset  Exit

System Overview
-----
AMIBIOS
Version      :08.00.15
Build Date   :08/17/09
ID:          :B151MT12

Processor
Intel® Atom CPU Z510 @ 1.10GHz
Speed       :1100MHz
Count       :1

System Memory
Size        :1019MB

System Time      [18:24:31]
System Time      [Tue 10/06/2009]

CMC Lo-Module:0D2.025x, Hi-Module:0D2.017x

v02.61 ©Copyright 1985-2006, American Megatrends, Inc.

Use [ENTER], [TAB] or [SHIFT-TAB] to select a field.
Use [+] or [-] to configure system time.

←→ Select Screen
↑↓ Select Item
Enter Go to SubScreen
F1 General Help
F10 Save and Exit
ESC Exit
    
```

### BIOS Menu 1: Main

- **System Overview**

The **System Overview** lists a brief summary of different system components. The fields in **System Overview** cannot be changed. The items shown in the system overview include:

- AMI BIOS: Displays auto-detected BIOS information
  - **Version:** Current BIOS version
  - **Build Date:** Date the current BIOS version was made
  - **ID:** Installed BIOS ID
- Processor: Displays auto-detected CPU specifications
  - **Type:** Names the currently installed processor
  - **Speed:** Lists the processor speed
  - **Count:** The number of CPUs on the motherboard
- System Memory: Displays the auto-detected system memory.

- **Size:** Lists memory size

The System Overview field also has two user configurable fields:

- **System Time [xx:xx:xx]**

Use the **System Time** option to set the system time. Manually enter the hours, minutes and seconds.

- **System Date [xx/xx/xx]**

Use the **System Date** option to set the system date. Manually enter the day, month and year.

## 5.3 Advanced

Use the **Advanced** menu (BIOS Menu 2) to configure the CPU and peripheral devices through the following sub-menus:



### **WARNING!**

Setting the wrong values in the sections below may cause the system to malfunction. Make sure that the settings made are compatible with the hardware.

- 
- CPU Configuration (see **Section 5.3.1**)
  - IDE Configuration (see **Section 5.3.2**)
  - Super IO Configuration (see **Section 5.3.3**)
  - Hardware Health Configuration (see **Section 5.3.4**)
  - Remote Access Configuration (see **Section 5.3.5**)
  - USB Configuration (see **Section 5.3.6**)



## UIBX-200-R11/Z510P Embedded System

```

BIOS SETUP UTILITY
Main  Advanced  PCIPNP  Boot  Security  Chipset  Exit
-----
Advanced Settings                                Configure CPU
-----
WARNING: Setting wrong values in below sections may cause
system to malfunction

> CPU Configuration
> IDE Configuration
> SuperIO Configuration
> Hardware Health Configuration
> Remote Access Configuration
> USB Configuration

                                  ←→  Select Screen
                                  ↑↓  Select Item
                                  Enter Go to SubScreen
                                  F1   General Help
                                  F10  Save and Exit
                                  ESC  Exit

v02.61 ©Copyright 1985-2006, American Megatrends, Inc.
  
```

### BIOS Menu 2: Advanced

#### 5.3.1 CPU Configuration

Use the **CPU Configuration** menu (BIOS Menu 3) to view detailed CPU specifications and configure the CPU.

```

BIOS SETUP UTILITY
Main  Advanced  PCIPNP  Boot  Security  Chipset  Exit
-----
Configure advanced CPU settings                    Disable:  Disable GV3
Module Version:3F.15                               Enable:   Enable GV3
-----
Manufacturer: Intel®
Intel® Atom CPU Z510 @ 1.10GHz
Frequency: 1.10GHz
FSB Speed: 400MHz

Cache L1: 24 KB
Cache L2: 512 KB
Ratio Actual Value:11

Intel® SpeedStep™ tech          [Enabled]
Intel® C-STATE tech            [Disabled]

                                  ←→  Select Screen
                                  ↑↓  Select Item
                                  Enter Go to SubScreen
                                  F1   General Help
                                  F10  Save and Exit
                                  ESC  Exit

v02.61 ©Copyright 1985-2006, American Megatrends, Inc.
  
```

### BIOS Menu 3: CPU Configuration

The CPU Configuration menu (BIOS Menu 3) lists the following CPU details:

- **Manufacturer:** Lists the name of the CPU manufacturer

- Brand String: Lists the brand name of the CPU being used
  - Frequency: Lists the CPU processing speed
  - FSB Speed: Lists the FSB speed
  - Cache L1: Lists the CPU L1 cache size
  - Cache L2: Lists the CPU L2 cache size
- **Intel® SpeedStep® Technology [Enabled]**

Intel® SpeedStep® allows the frequency and voltage of the CPU to be adjusted by system software. Reducing the voltage and frequency reduces power consumption of the CPU when it is not being used heavily. It is recommended to leave this setting enabled.

- **Intel® C-State Technology [Disabled]**

Intel® C-State is for power saving when the CPU is idle, enabling lower voltages and reduced frequency.

### 5.3.2 IDE Configuration

Use the **IDE Configuration** menu (BIOS Menu 4) to change and/or set the configuration of the IDE devices installed in the system.

```

BIOS SETUP UTILITY
Main  Advanced  PCIPNP  Boot  Security  Chipset  Exit
-----
IDE Configuration
-----
OnBoard PCI IDE Controller      [Primary]

> Primary IDE Master           : [Hard Disk]
> Primary IDE Slave            : [Not Detected]

                                  ←→  Select Screen
                                  ↑↓  Select Item
                                  Enter Go to SubScreen
                                  F1   General Help
                                  F10  Save and Exit
                                  ESC   Exit

v02.61 ©Copyright 1985-2006, American Megatrends, Inc.

```

**BIOS Menu 4: IDE Configuration**

## UIBX-200-R11/Z510P Embedded System

- Parallel ATA IDE devices

Displays the settings for all the IDE devices. The devices listed below are available.

- Primary IDE Master
- Primary IDE Slave

### 5.3.2.1 SATA Channel

Sets the IDE configuration of the SATA channels.

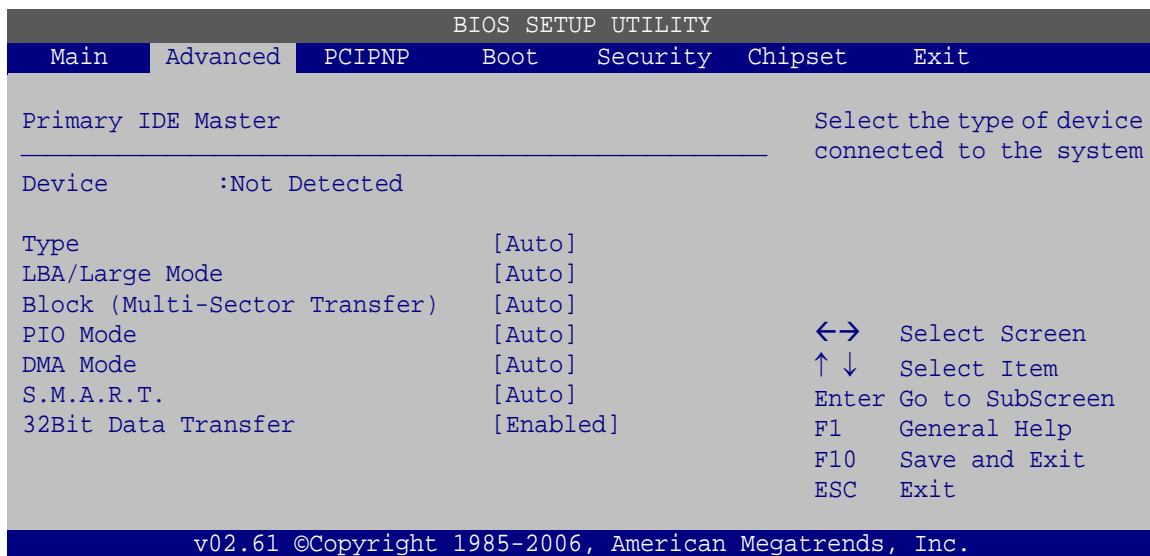

#### BIOS Menu 5: IDE Master and IDE Slave Configuration

- Type [Auto]

Use the **Type** BIOS option select the type of device the AMIBIOS attempts to boot from after the Power-On Self-Test (POST) is complete.

- ➔ **Not Installed** BIOS is prevented from searching for an IDE disk drive on the specified channel.
- ➔ **Auto** **DEFAULT** The BIOS auto detects the IDE disk drive type attached to the specified channel. This setting should be used if an IDE hard disk drive is attached to the specified channel.

## UIBX-200-R11/Z510P Embedded System

→ **CD/DVD**

The CD/DVD option specifies that an IDE CD-ROM drive is attached to the specified IDE channel. The BIOS does not attempt to search for other types of IDE disk drives on the specified channel.

→ **ARMD**

This option specifies an ATAPI Removable Media Device. These include, but are not limited to:

ZIP

LS-120

▪ **LBA/Large Mode [Auto]**

Use the **LBA/Large Mode** option to disable or enable BIOS to auto detects LBA (Logical Block Addressing). LBA is a method of addressing data on a disk drive. In LBA mode, the maximum drive capacity is 137 GB.

→ **Disabled**

BIOS is prevented from using the LBA mode control on the specified channel.

→ **Auto**      **DEFAULT**

BIOS auto detects the LBA mode control on the specified channel.

▪ **Block (Multi Sector Transfer) [Auto]**

Use the **Block (Multi Sector Transfer)** to disable or enable BIOS to auto detect if the device supports multi-sector transfers.

→ **Disabled**

BIOS is prevented from using Multi-Sector Transfer on the specified channel. The data to and from the device occurs one sector at a time.

→ **Auto**      **DEFAULT**

BIOS auto detects Multi-Sector Transfer support on the drive on the specified channel. If supported the data transfer to and from the device occurs multiple sectors at a time.

## UIBX-200-R11/Z510P Embedded System

- **PIO Mode [Auto]**

Use the **PIO Mode** option to select the IDE PIO (Programmable I/O) mode program timing cycles between the IDE drive and the programmable IDE controller. As the PIO mode increases, the cycle time decreases.

- ➔ **Auto**    **DEFAULT**    BIOS auto detects the PIO mode. Use this value if the IDE disk drive support cannot be determined.
- ➔ **0**                    PIO mode 0 selected with a maximum transfer rate of 3.3 MB/s
- ➔ **1**                    PIO mode 1 selected with a maximum transfer rate of 5.2 MB/s
- ➔ **2**                    PIO mode 2 selected with a maximum transfer rate of 8.3 MB/s
- ➔ **3**                    PIO mode 3 selected with a maximum transfer rate of 11.1 MB/s
- ➔ **4**                    PIO mode 4 selected with a maximum transfer rate of 16.6 MB/s  
(This setting generally works with all hard disk drives manufactured after 1999. For other disk drives, such as IDE CD-ROM drives, check the specifications of the drive.)

- **DMA Mode [Auto]**

Use the **DMA Mode** BIOS selection to adjust the DMA mode options.

- ➔ **Auto**            **DEFAULT**    BIOS auto detects the DMA mode. Use this value if the IDE disk drive support cannot be determined.
- ➔ **SWDMA0**            Single Word DMA mode 0 selected with a maximum data transfer rate of 2.1 MB/s
- ➔ **SWDMA1**            Single Word DMA mode 1 selected with a maximum data transfer rate of 4.2 MB/s
- ➔ **SWDMA2**            Single Word DMA mode 2 selected with a maximum data transfer rate of 8.3 MB/s
- ➔ **MWDMA0**            Multi Word DMA mode 0 selected with a maximum data transfer rate of 4.2 MB/s

## UIBX-200-R11/Z510P Embedded System

- ➔ **MWDMA1** Multi Word DMA mode 1 selected with a maximum data transfer rate of 13.3 MB/s
- ➔ **MWDMA2** Multi Word DMA mode 2 selected with a maximum data transfer rate of 16.6 MB/s
- ➔ **UDMA0** Ultra DMA mode 0 selected with a maximum data transfer rate of 16.6 MB/s
- ➔ **UDMA1** Ultra DMA mode 1 selected with a maximum data transfer rate of 25 MB/s
- ➔ **UDMA2** Ultra DMA mode 2 selected with a maximum data transfer rate of 33.3 MB/s
- ➔ **UDMA3** Ultra DMA mode 3 selected with a maximum data transfer rate of 44 MB/s (To use this mode, it is required that an 80-conductor ATA cable is used.)
- ➔ **UDMA4** Ultra DMA mode 4 selected with a maximum data transfer rate of 66.6 MB/s (To use this mode, it is required that an 80-conductor ATA cable is used.)
- ➔ **UDMA5** Ultra DMA mode 5 selected with a maximum data transfer rate of 99.9 MB/s (To use this mode, it is required that an 80-conductor ATA cable is used.)

- **S.M.A.R.T [Auto]**

Use the **S.M.A.R.T** option to auto-detect, disable or enable Self-Monitoring Analysis and Reporting Technology (SMART) on the drive on the specified channel. **S.M.A.R.T** predicts impending drive failures. The **S.M.A.R.T** BIOS option enables or disables this function.

- ➔ **Auto**      **DEFAULT**      BIOS auto detects HDD SMART support.
- ➔ **Disabled**      Prevents BIOS from using the HDD SMART feature.
- ➔ **Enabled**      Allows BIOS to use the HDD SMART feature

- **32Bit Data Transfer [Enabled]**

Use the **32Bit Data Transfer** BIOS option to enables or disable 32-bit data transfers.

## UIBX-200-R11/Z510P Embedded System

- ➔ **Disabled** Prevents the BIOS from using 32-bit data transfers.
- ➔ **Enabled** **DEFAULT** Allows BIOS to use 32-bit data transfers on supported hard disk drives.

### 5.3.3 Super IO Configuration

Use the **Super IO Configuration** menu (BIOS Menu 6) to set or change the configurations for the FDD controllers, parallel ports and serial ports.

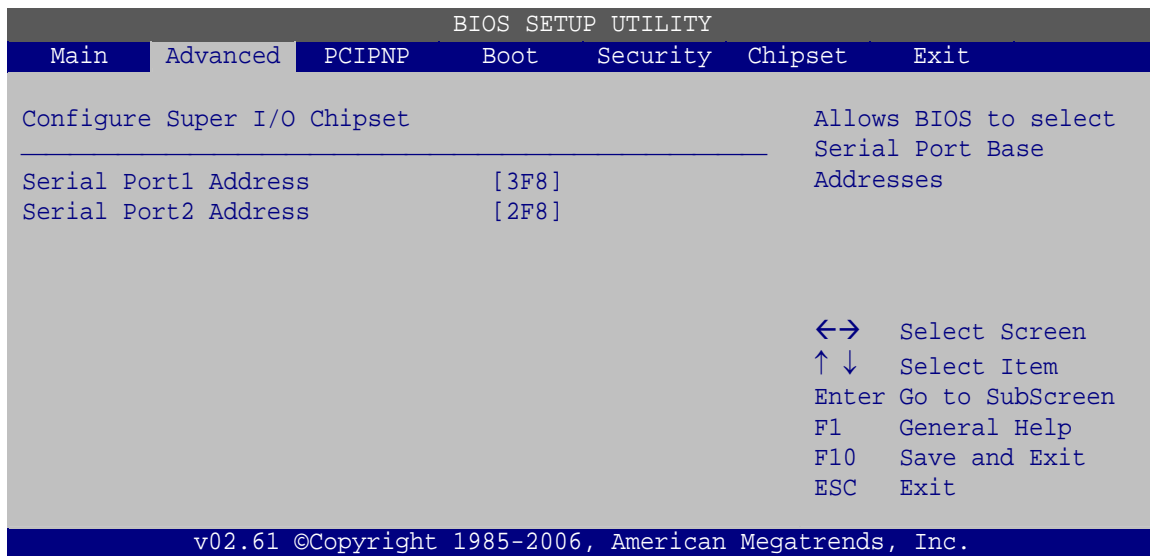

#### BIOS Menu 6: Super IO Configuration

- **Serial Port1 Address [3F8]**

Sets the port address of serial port 1.

- Disabled
- 3F8 **DEFAULT**
- 2F8
- 3E8
- 2E8

- **Serial Port1 IRQ [4]**

Sets the interrupt request for serial port 1.

- 3
- 4                   **DEFAULT**

▪ **Serial Port2 Address [2F8]**

Sets the port address of serial port 2.

- Disabled
- 3F8
- 2F8                   **DEFAULT**
- 3E8
- 2E8

▪ **Serial Port2 IRQ [3]**

Sets the interrupt request for serial port 2.

- 3                   **DEFAULT**
- 4

### 5.3.4 Hardware Health Configuration

The **Hardware Health Configuration** menu (**BIOS Menu 7**) shows the operating temperature, fan speeds and system voltages.

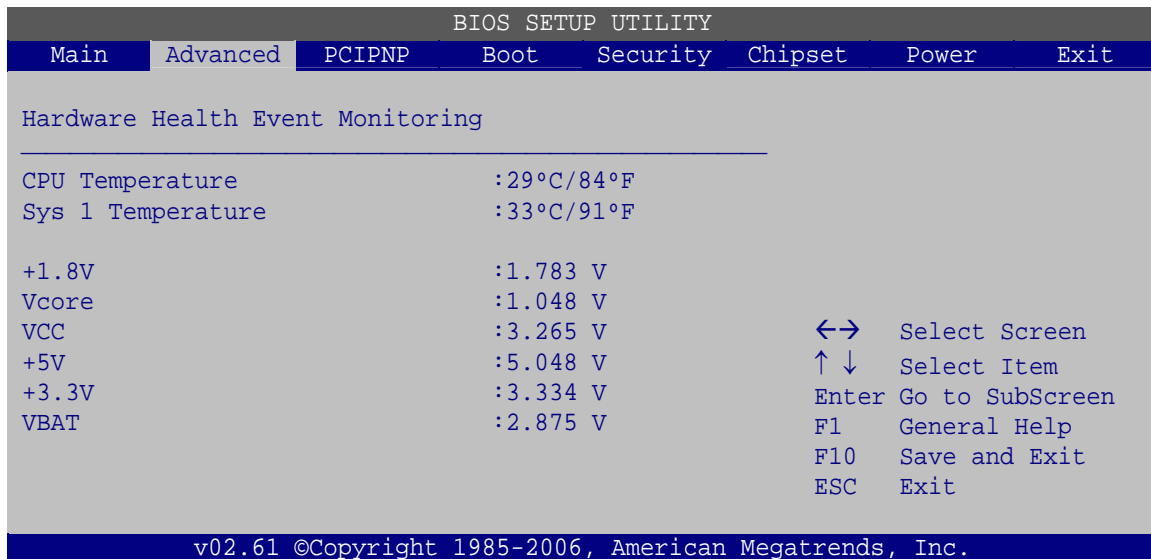

**BIOS Menu 7: Hardware Health Configuration**



## UIBX-200-R11/Z510P Embedded System

### → Hardware Health Monitoring

The following system parameters and values are shown. The system parameters that are monitored are:

- System Temperatures:
  - CPU Temperature
  - System Temperature
- Voltages:
  - +1.8V
  - Vcore
  - VCC
  - +5V
  - +3.3V
  - VBAT

### 5.3.5 Remote Access Configuration

Use the **Remote Access Configuration** menu (BIOS Menu 8) to configure remote access parameters. The **Remote Access Configuration** is an AMIBIOS feature and allows a remote host running a terminal program to display and configure the BIOS settings.

```

BIOS SETUP UTILITY
Main  Advanced  PCIPNP  Boot  Security  Chipset  Exit
-----
Configure Remote Access type and parameters
-----
Remote Access                [Disabled]

Serial port number            [COM1]
  Base Address, IRQ           [3F8H, 4]
Serial Port Mode              [115200 8,n,1]
Redirection After BIOS POST   [Always]
Terminal Type                 [ANSI]

                                  ←→  Select Screen
                                  ↑↓  Select Item
                                  Enter Go to SubScreen
                                  F1   General Help
                                  F10  Save and Exit
                                  ESC  Exit

v02.61 ©Copyright 1985-2006, American Megatrends, Inc.

```

**BIOS Menu 8: Remote Access Configuration**

- **Remote Access [Disabled]**

Use the **Remote Access** option to enable or disable access to the remote functionalities of the system.

- ➔ **Disabled**      **DEFAULT**      Remote access is disabled.
- ➔ **Enabled**                      Remote access configuration options shown below appear:

- Serial Port Number
- Serial Port Mode
- Flow Control
- Redirection after BIOS POST
- Terminal Type
- VT-UTF8 Combo Key Support

These configuration options are discussed below.

- **Serial Port Number [COM1]**

Use the **Serial Port Number** option allows to select the serial port used for remote access.

- ➔ **COM1**      **DEFAULT**      System is remotely accessed through COM1
- ➔ **COM2**                      System is remotely accessed through COM2

**NOTE:** Make sure the selected COM port is enabled through the Super I/O configuration menu.

- **Base Address, IRQ [3F8h,3]**

The **Base Address, IRQ** option cannot be configured and only shows the interrupt address of the serial port listed above.

- **Serial Port Mode [115200 8,n,1]**

Use the **Serial Port Mode** option to select baud rate through which the console redirection is made. The following configuration options are available

## UIBX-200-R11/Z510P Embedded System

- 115200 8,n,1 **DEFAULT**
- 57600 8,n,1
- 38400 8,n,1
- 19200 8,n,1
- 09600 8,n,1



### NOTE:

Identical baud rate setting must be set on the host (a management computer running a terminal software) and the slave

- **Redirection After BIOS POST [Always]**

Use the **Redirection After BIOS POST** option to specify when console redirection should occur.

- |   |                    |                |  |
|---|--------------------|----------------|--|
| ➔ | <b>Disabled</b>    | <b>DEFAULT</b> | The console is not redirected after POST                               |
| ➔ | <b>Boot Loader</b> |                | Redirection is active during POST and during Boot Loader               |
| ➔ | <b>Always</b>      | <b>DEFAULT</b> | Redirection is always active (Some OSES may not work if set to Always) |

- **Terminal Type [ANSI]**

Use the **Terminal Type** BIOS option to specify the remote terminal type.

- |   |                |                |                                     |
|---|----------------|----------------|-------------------------------------|
| ➔ | <b>ANSI</b>    | <b>DEFAULT</b> | The target terminal type is ANSI    |
| ➔ | <b>VT100</b>   |                | The target terminal type is VT100   |
| ➔ | <b>VT-UTF8</b> |                | The target terminal type is VT-UTF8 |

### 5.3.6 USB Configuration

Use the **USB Configuration** menu (BIOS Menu 9) to read USB configuration information and configure the USB settings.

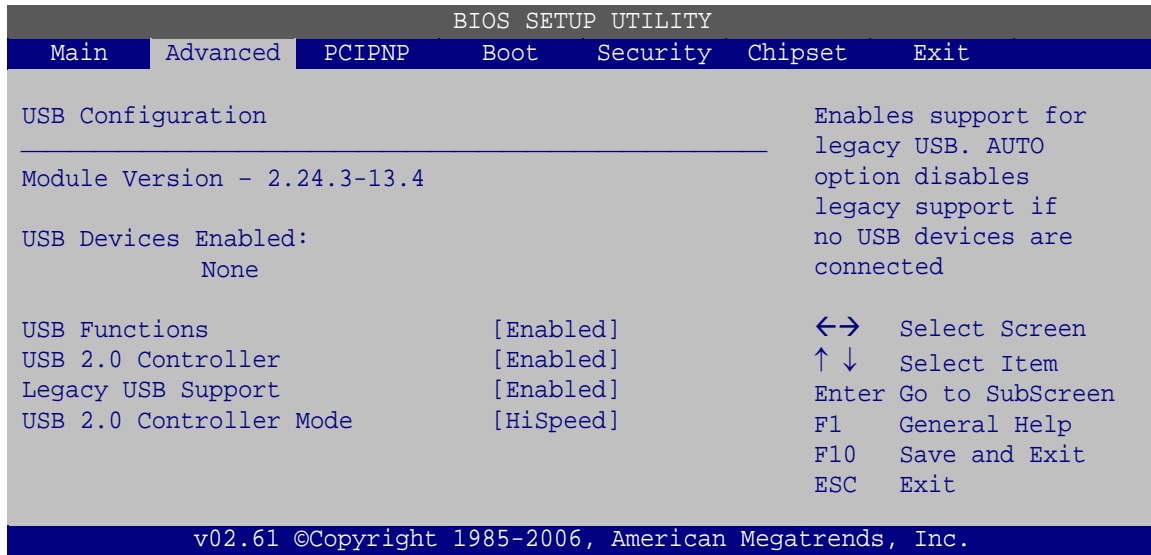

#### BIOS Menu 9: USB Configuration

- **USB Function [Enabled]**

When enabled, USB devices can be used in the USB slots.

- Disabled **DEFAULT**
- Enabled

- **USB 2.0 Controller [Enabled]**

The USB ports will only operate in the legacy USB 1.1 mode unless this setting is enabled.

- Disabled **DEFAULT**
- Enabled

- **Legacy USB Support [Enabled]**

Use the **Legacy USB Support** BIOS option to enable USB mouse and USB keyboard support.

## UIBX-200-R11/Z510P Embedded System

Normally if this option is not enabled, any attached USB mouse or USB keyboard does not become available until a USB compatible operating system is fully booted with all USB drivers loaded. When this option is enabled, any attached USB mouse or USB keyboard can control the system even when there is no USB driver loaded onto the system.

- ➔ **Disabled** Legacy USB support disabled
- ➔ **Enabled**     **DEFAULT** Legacy USB support enabled
- ➔ **Auto** Legacy USB support disabled if no USB devices are connected

- **USB2.0 Controller Mode [HiSpeed]**

Use the **USB2.0 Controller Mode** option to set the speed of the USB2.0 controller.

- ➔ **FullSpeed** The controller is capable of operating at 12 Mb/s
- ➔ **HiSpeed**     **DEFAULT** The controller is capable of operating at 480 Mb/s

### 5.3.6.1 USB Mass Storage Device Configuration

Use the **USB Mass Storage Device Configuration** menu (BIOS Menu 10) to configure USB mass storage class devices.

```

BIOS SETUP UTILITY
Main  Advanced  PCIPNP  Boot  Security  Chipset  Exit
-----
USB Mass Storage Device Configuration
-----
USB Mass Storage Reset Delay    [20 Sec]

Device #1          M-SysT5 Dell Memory Key 5.04
Emulation Type     [Auto]

                                  ←→  Select Screen
                                  ↑↓  Select Item
                                  Enter Go to SubScreen
                                  F1   General Help
                                  F10  Save and Exit
                                  ESC  Exit

v02.61 ©Copyright 1985-2006, American Megatrends, Inc.

```

**BIOS Menu 10: USB Mass Storage Device Configuration**

- **USB Mass Storage Reset Delay [20 Sec]**

Use the **USB Mass Storage Reset Delay** option to set the number of seconds POST waits for the USB mass storage device after the start unit command.

- ➔ **10 Sec** POST waits 10 seconds for the USB mass storage device after the start unit command.
- ➔ **20 Sec** **DEFAULT** POST waits 20 seconds for the USB mass storage device after the start unit command.
- ➔ **30 Sec** POST waits 30 seconds for the USB mass storage device after the start unit command.
- ➔ **40 Sec** POST waits 40 seconds for the USB mass storage device after the start unit command.

- **Device ##**

The **Device##** field lists the USB devices that are connected to the system.

- **Emulation Type [Auto]**

Use the **Emulation Type** BIOS option to specify the type of emulation BIOS has to provide for the USB device.

- ➔ **Auto** **DEFAULT** BIOS auto-detects the current USB.
- ➔ **Floppy** The USB device will be emulated as a floppy drive. The device can be either A: or B: responding to INT13h calls that return DL = 0 or DL = 1 respectively.
- ➔ **Forced FDD** Allows a hard disk image to be connected as a floppy image. This option works only for drives formatted with FAT12, FAT16 or FAT32.
- ➔ **Hard Disk** Allows the USB device to be emulated as hard disk responding to INT13h calls that return DL values of 80h or above.

## UIBX-200-R11/Z510P Embedded System

### → CDROM

Assumes the CD-ROM is formatted as bootable media. All the devices that support block sizes greater than 512 bytes can only be booted using this option.

## 5.4 PCI/PnP

Use the **PCI/PnP** menu (BIOS Menu 11) to configure advanced PCI and PnP settings.



### WARNING!

Setting wrong values for the BIOS selections in the PCIPnP BIOS menu may cause the system to malfunction.

```

BIOS SETUP UTILITY
Main  Advanced  PCIPNP  Boot  Security  Chipset  Exit
-----
Advanced PCI/PnP Settings
-----
WARNING: Setting wrong values in below sections
         may cause system to malfunction
IRQ3           [Reserved]
IRQ4           [Reserved]
IRQ5           [Available]
IRQ7           [Available]
IRQ9           [Available]
IRQ10          [Available]
IRQ11          [Available]
IRQ14          [Available]
IRQ15          [Available]
Reserved Memory Size [Disabled]

Available: Specified
IRQ is available to be
used by PCI/PnP
devices.
Reserved: Specified
IRQ is reserved for
use by Legacy ISA
devices.
←→  Select Screen
↑↓  Select Item
Enter Go to SubScreen
F1   General Help
F10  Save and Exit
ESC  Exit

v02.61 ©Copyright 1985-2006, American Megatrends, Inc.
    
```

### BIOS Menu 11: PCI/PnP Configuration

- **IRQ# [Available]**

Use the **IRQ#** address to specify what IRQs can be assigned to a particular peripheral device.

## UIBX-200-R11/Z510P Embedded System

- ➔ **Available**     **DEFAULT**     The specified IRQ is available to be used by PCI/PnP devices
- ➔ **Reserved**     The specified IRQ is reserved for use by Legacy ISA devices

Available IRQ addresses are:

- IRQ3
  - IRQ4
  - IRQ5
  - IRQ7
  - IRQ9
  - IRQ10
  - IRQ 11
  - IRQ 14
  - IRQ 15
- 
- **Reserved Memory Size [Disabled]**

Use the **Reserved Memory Size** BIOS option to specify the amount of memory that should be reserved for legacy ISA devices.

- ➔ **Disabled**     **DEFAULT**     No memory block reserved for legacy ISA devices
- ➔ **16K**     16 KB reserved for legacy ISA devices
- ➔ **32K**     32 KB reserved for legacy ISA devices
- ➔ **64K**     64 KB reserved for legacy ISA devices



## 5.5 Boot

Use the **Boot** menu (BIOS Menu 12) to configure system boot options.

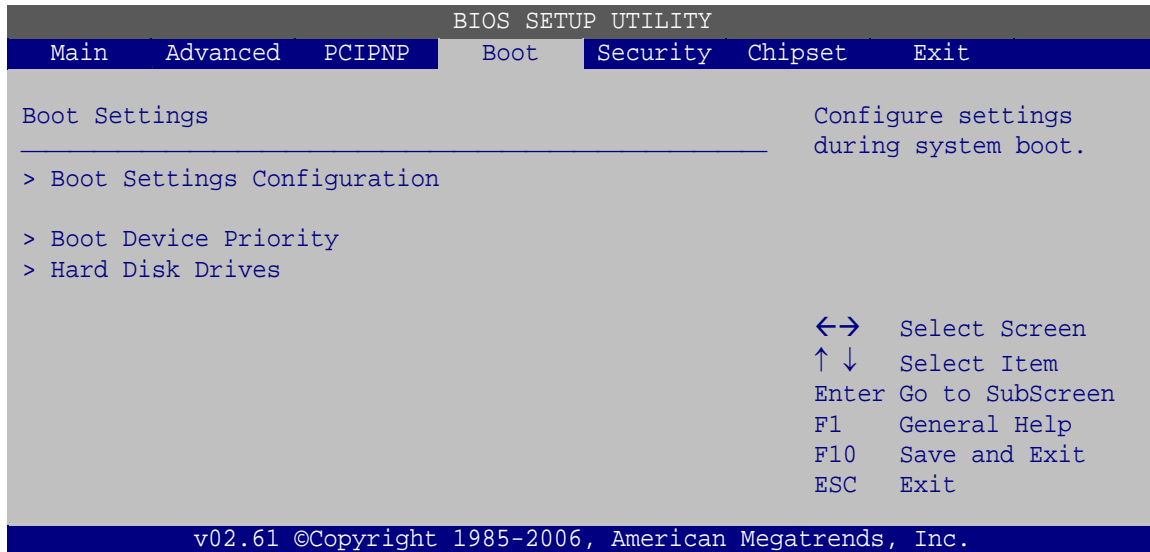

**BIOS Menu 12: Boot**

### 5.5.1 Boot Settings Configuration

Use the **Boot Settings Configuration** menu (BIOS Menu 13) to configure advanced system boot options.

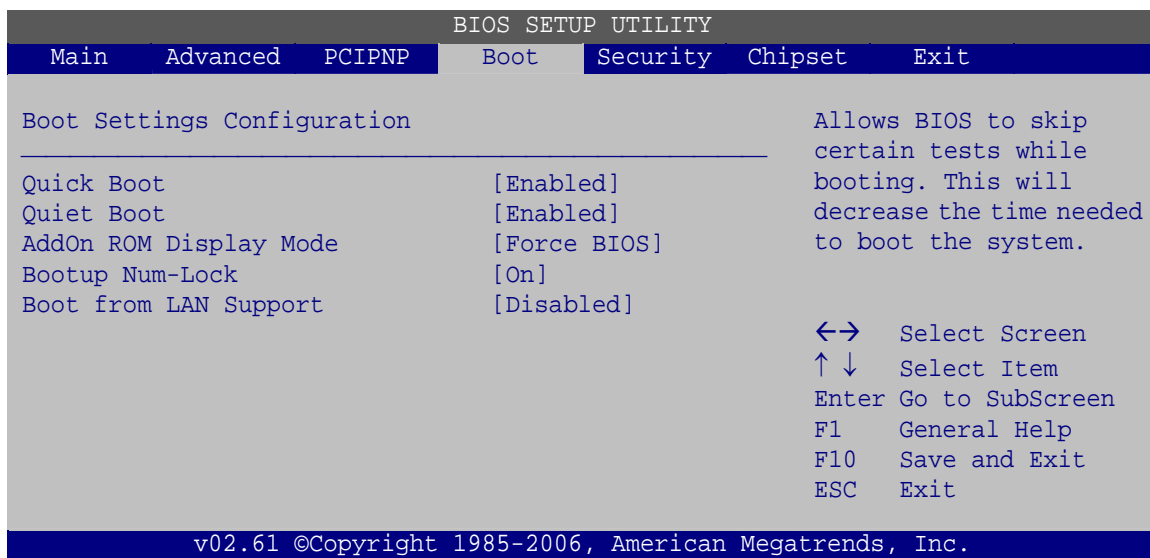

**BIOS Menu 13: Boot Settings Configuration**

- **Quick Boot [Enabled]**

Use the **Quick Boot** BIOS option to make the computer speed up the boot process.

- ➔ **Disabled** No POST procedures are skipped
- ➔ **Enabled** **DEFAULT** Some POST procedures are skipped to decrease the system boot time

- **Quiet Boot [Disabled]**

Use the **Quiet Boot** BIOS option to select the screen display when the system boots.

- ➔ **Disabled** **DEFAULT** Normal POST messages displayed
- ➔ **Enabled** OEM Logo displayed instead of POST messages

- **AddOn ROM Display Mode [Force BIOS]**

Use the **AddOn ROM Display Mode** option to allow add-on ROM (read-only memory) messages to be displayed.

- ➔ **Force BIOS** **DEFAULT** The system forces third party BIOS to display during system boot.
- ➔ **Keep Current** The system displays normal information during system boot.

- **Bootup Num-Lock [On]**

Use the **Bootup Num-Lock** BIOS option to specify if the number lock setting must be modified during boot up.

- ➔ **Off** Does not enable the keyboard Number Lock automatically. To use the 10-keys on the keyboard, press the Number Lock key located on the upper left-hand corner of the 10-key pad. The Number Lock LED on the keyboard lights up when the Number Lock is engaged.

## UIBX-200-R11/Z510P Embedded System

- ➔ **On** **DEFAULT** Allows the Number Lock on the keyboard to be enabled automatically when the computer system boots up. This allows the immediate use of the 10-key numeric keypad located on the right side of the keyboard. To confirm this, the Number Lock LED light on the keyboard is lit.

- **Boot From LAN Support [Disabled]**

Use the **BOOT From LAN Support** option to enable the system to be booted from a remote system.

- ➔ **Disabled** **DEFAULT** Cannot be booted from a remote system through the LAN
- ➔ **Enabled** Can be booted from a remote system through the LAN

### 5.5.2 Boot Device Priority

Use the **Boot Device Priority** menu (BIOS Menu 14) to specify the boot sequence from the available devices. The drive sequence also depends on the boot sequence in the individual device section.

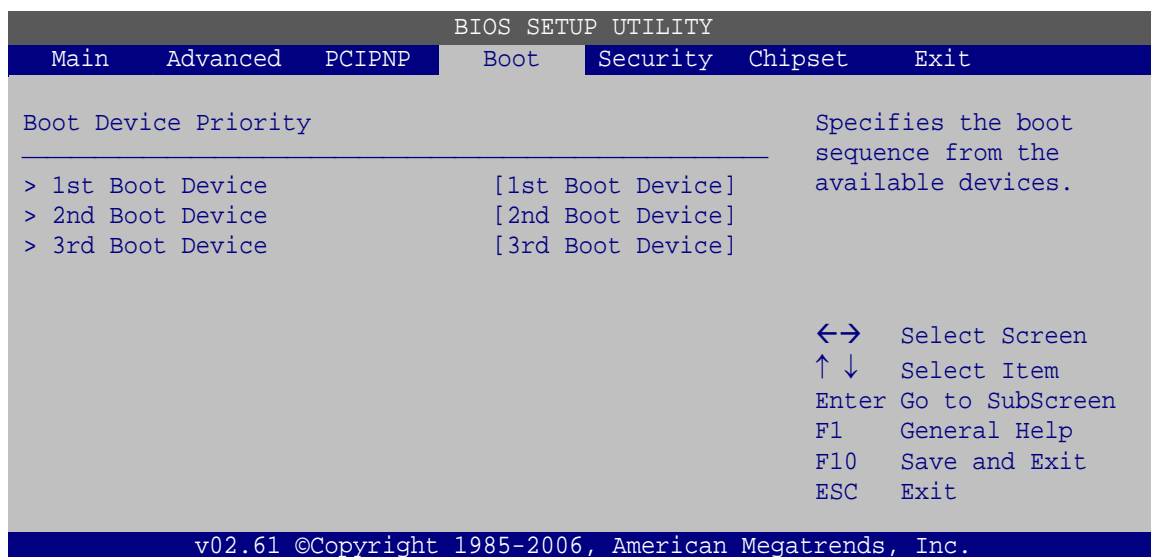

**BIOS Menu 14: Boot Device Priority Settings**

### 5.5.3 Hard Disk Drives

Use the **Hard Disk Drives** menu to specify the boot sequence of the available HDDs. Only installed hard drives are shown.

```

BIOS SETUP UTILITY
Main  Advanced  PCIPNP  Boot  Security  Chipset  Exit
-----
Hard Disk Drives
-----
> 1st Drive      [Hard Drive 1]
> 2nd Drive      [Hard Drive 2]
> 3rd Drive      [Hard Drive 3]

Specifies the boot
sequence from the
available devices.

<=>  Select Screen
↑↓   Select Item
Enter Go to SubScreen
F1   General Help
F10  Save and Exit
ESC  Exit

v02.61 ©Copyright 1985-2006, American Megatrends, Inc.

```

**BIOS Menu 15: Hard Disk Drives**

### 5.6 Security

Use the **Security** menu (BIOS Menu 16) to set system and user passwords.

```

BIOS SETUP UTILITY
Main  Advanced  PCIPNP  Boot  Security  Chipset  Exit
-----
Security Settings
-----
Supervisor Password :Not Installed
User Password       :Not Installed

Change Supervisor Password
Change User Password

<=>  Select Screen
↑↓   Select Item
Enter Go to SubScreen
F1   General Help
F10  Save and Exit
ESC  Exit

v02.61 ©Copyright 1985-2006, American Megatrends, Inc.

```

**BIOS Menu 16: Security**

## UIBX-200-R11/Z510P Embedded System

- **Change Supervisor Password**

Use the **Change Supervisor Password** to set or change a supervisor password. The default for this option is **Not Installed**. If a supervisor password must be installed, select this field and enter the password. After the password has been added, **Install** appears next to **Change Supervisor Password**.

- **Change User Password**

Use the **Change User Password** to set or change a user password. The default for this option is **Not Installed**. If a user password must be installed, select this field and enter the password. After the password has been added, **Install** appears next to **Change User Password**.

## 5.7 Chipset

Use the **Chipset** menu (BIOS Menu 17) to access the Northbridge and Southbridge configuration menus



### **WARNING!**

Setting the wrong values for the Chipset BIOS selections in the Chipset BIOS menu may cause the system to malfunction.

---

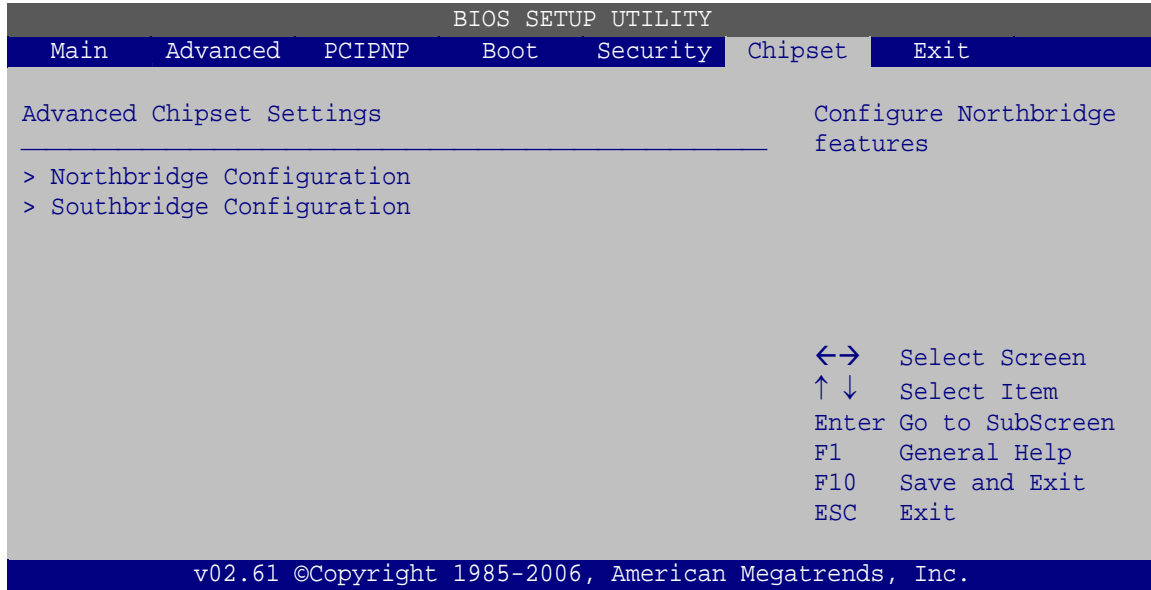
**BIOS Menu 17: Chipset**
**5.7.1 Northbridge Configuration**

Use the **Northbridge Configuration** configures the system chipset.

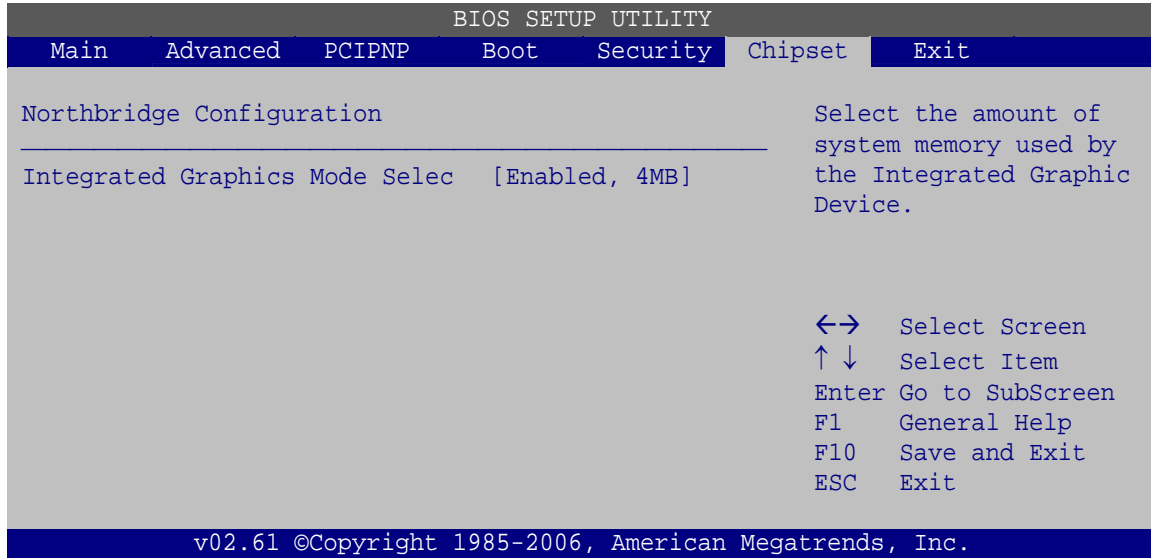
**BIOS Menu 18:Northbridge Chipset Configuration**

- **Integrated Graphics Mode Selec [Enabled, 4MB]**

Specifies how much memory is allocated to the graphics.

## UIBX-200-R11/Z510P Embedded System

- Disabled
- Enabled, 1MB
- Enabled, 4MB **DEFAULT**
- Enabled, 8MB

### 5.7.2 Southbridge Configuration

The **Southbridge Configuration** configures the system chipset.

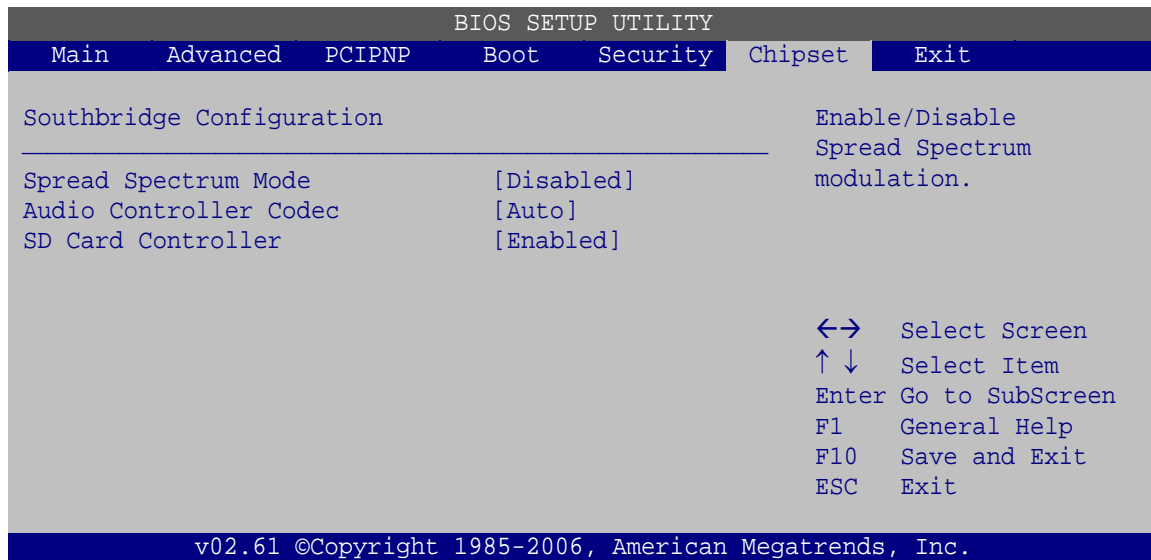

#### BIOS Menu 19:Southbridge Chipset Configuration

- **Audio Controller Codec [Auto]**

Enables and disables the onboard audio.

- ➔ **Disabled** Audio chip disabled
- ➔ **Auto** **DEFAULT** Audio chip enabled if audio devices are attached

- ➔ **Spread Spectrum Mode [Disabled]**

The **Spread Spectrum Mode** option can help to improve CPU EMI issues.

- ➔ **Disabled** **DEFAULT** The spread spectrum mode is disabled
- ➔ **Enabled** The spread spectrum mode is enabled

**→ SD Card Controller [Enabled]**

The **SD Card Controller** must be enabled if SD cards are installed internally.

- **Disabled**                      SD cards will not be detected
- **Enabled**      **DEFAULT**      SD cards will be detected and available for storage

## 5.8 Exit

Use the **Exit** menu (BIOS Menu 20) to load default BIOS values, optimal failsafe values and to save configuration changes.

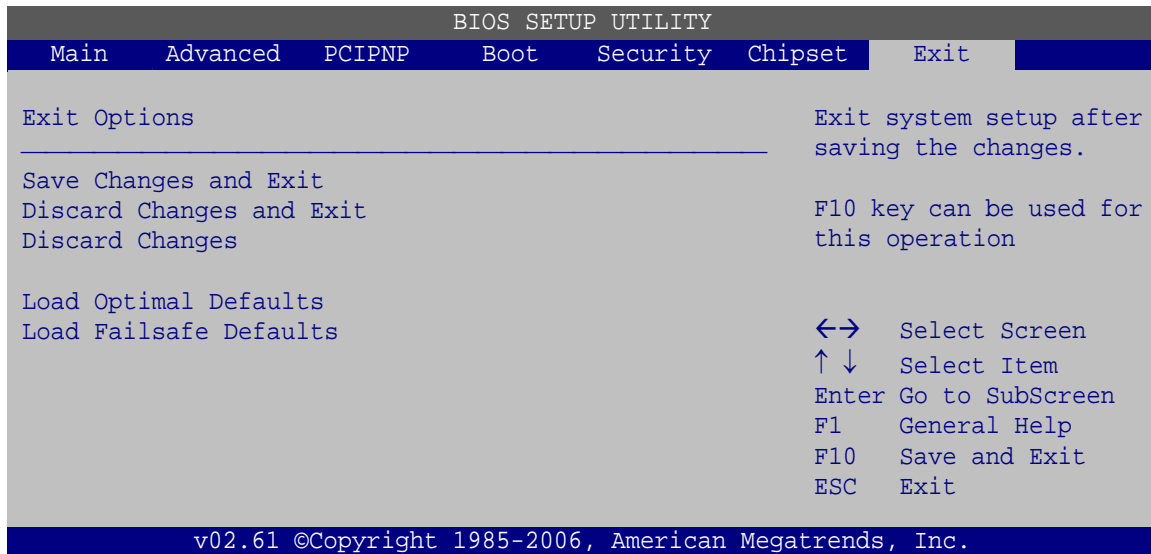

### BIOS Menu 20:Exit

- **Save Changes and Exit**

Use the **Save Changes and Exit** option to save the changes made to the BIOS options and to exit the BIOS configuration setup program.

- **Discard Changes and Exit**

Use the **Discard Changes and Exit** option to exit the BIOS configuration setup program without saving the changes made to the system.



## UIBX-200-R11/Z510P Embedded System

- **Discard Changes**

Use the **Discard Changes** option to discard the changes and remain in the BIOS configuration setup program.

- **Load Optimal Defaults**

Use the **Load Optimal Defaults** option to load the optimal default values for each of the parameters on the Setup menus. **F9 key can be used for this operation.**

- **Load Failsafe Defaults**

Use the **Load Failsafe Defaults** option to load failsafe default values for each of the parameters on the Setup menus. **F8 key can be used for this operation.**



Appendix

A

# One Key Recovery

---

## A.1 One Key Recovery Introduction

The IEI one key recovery is an easy-to-use front end for the Norton Ghost system backup and recovery tool. The one key recovery provides quick and easy shortcuts for creating a backup and reverting to that backup or for reverting to the factory default settings.

The IEI One Key Recovery tool menu is shown below.

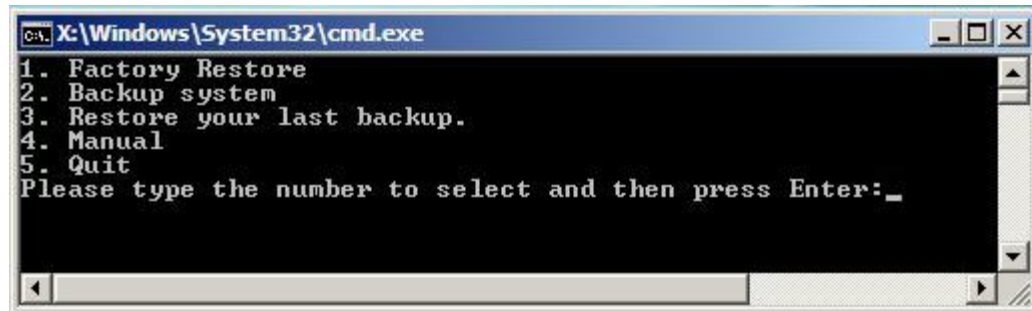

Figure A-1: IEI One Key Recovery Tool Menu

Prior to using the IEI One Key Recovery tool (as shown in **Figure A-1**) to backup or restore Windows system, five setup procedures are required.

1. Hardware and BIOS setup (see **Section A.2.1**)
2. Create partitions (see **Section A.2.2**)
3. Install operating system, drivers and system applications (see **Section A.2.3**)
4. Build-up recovery partition (see **Section A.2.4**)
5. Create factory default image (see **Section A.2.5**)

After completing the five initial setup procedures as described above, users can access the recovery tool by pressing <F3> while booting up the system. The detailed information of each function is described in **Section A.4**.



### NOTE:

The initial setup procedures for Linux system are described in **Section A.3**.

---

### A.1.1 System Requirement



**NOTE:**

The recovery CD can only be used with IEI products. The software will fail to run and a warning message will appear when used on non-IEI hardware.

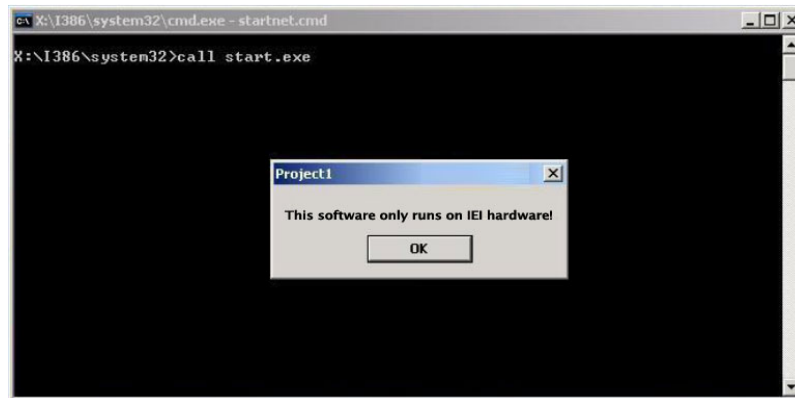

To create the system backup, the main storage device must be split into two partitions (three partitions for Linux). The first partition will be for the operating system, while the second partition will be invisible to the operating system and contain the backup made by the one key recovery software.

The partition created for recovery images must be big enough to contain both the factory default image and the user backup image. The size must be calculated before creating the partitions. Please take the following table as a reference when calculating the size of the partition.

	OS	OS Image after Ghost	Compression Ratio
<b>Windows® 7</b>	7 GB	5 GB	70%
<b>Windows® XPE</b>	776 MB	560 MB	70%
<b>Windows® CE 6.0</b>	36 MB	28 MB	77%

**NOTE:**

Specialized tools are required to change the partition size if the operating system is already installed.

**A.1.2 Supported Operating System**

The recovery CD is compatible with both Microsoft Windows and Linux operating system (OS). The supported OS versions are listed below.

- Microsoft Windows
  - Windows XP (Service Pack 2 or 3 required)
  - Windows Vista
  - Windows 7
  - Windows CE 5.0
  - Windows CE 6.0
  - Windows XP Embedded
- Linux
  - Fedora Core 12 (Constantine)
  - Fedora Core 11 (Leonidas)
  - Fedora Core 10 (Cambridge)
  - Fedora Core 8 (Werewolf)
  - Fedora Core 7 (Moonshine)
  - RedHat RHEL-5.4
  - RedHat 9 (Ghirke)
  - Ubuntu 8.10 (Intrepid)
  - Ubuntu 7.10 (Gutsy)
  - Ubuntu 6.10 (Edgy)
  - Debian 5.0 (Lenny)
  - Debian 4.0 (Etch)
  - SuSe 11.2
  - SuSe 10.3

**NOTE:**

Installing unsupported OS versions may cause the recovery tool to fail.

## A.2 Setup Procedure for Windows

Prior to using the recovery tool to backup or restore Windows system, a few setup procedures are required.

**Step 1:** Hardware and BIOS setup (see **Section A.2.1**)

**Step 2:** Create partitions (see **Section A.2.2**)

**Step 3:** Install operating system, drivers and system applications (see **Section A.2.3**)

**Step 4:** Build-up recovery partition (see **Section A.2.4**)

**Step 5:** Create factory default image (see **Section A.2.5**)

The detailed descriptions are described in the following sections.

**NOTE:**

The setup procedures described below are for Microsoft Windows operating system users. For Linux system, most setup procedures are the same with Microsoft Windows except for several steps described in **Section A.3**.

### A.2.1 Hardware and BIOS Setup

**Step 1:** Make sure the system is powered off and unplugged.

**Step 2:** Install a hard drive or SSD in the system. An unformatted and unpartitioned disk is recommended.

**Step 3:** Connect an optical disk drive to the system and insert the recovery CD.

## UIBX-200-R11/Z510P Embedded System

- Step 4:** Turn on the system.
- Step 5:** Press the <DELETE> key as soon as the system is turned on to enter the BIOS.
- Step 6:** Select the connected optical disk drive as the 1<sup>st</sup> boot device. (**Boot** → **Boot Device Priority** → **1<sup>st</sup> Boot Device**).
- Step 7:** Save changes and restart the computer. Continue to the next section for instructions on partitioning the internal storage.

### A.2.2 Create Partitions

To create the system backup, the main storage device must be split into two partitions (three partitions for Linux). The first partition will be for the operating system, while the second partition will be invisible to the operating system and contain the backup made by the one key recovery software.

- Step 1:** Put the recovery CD in the optical drive of the system.
- Step 2:** **Boot the system from recovery CD.** When prompted, press any key to boot from the recovery CD. It will take a while to launch the recovery tool. Please be patient!

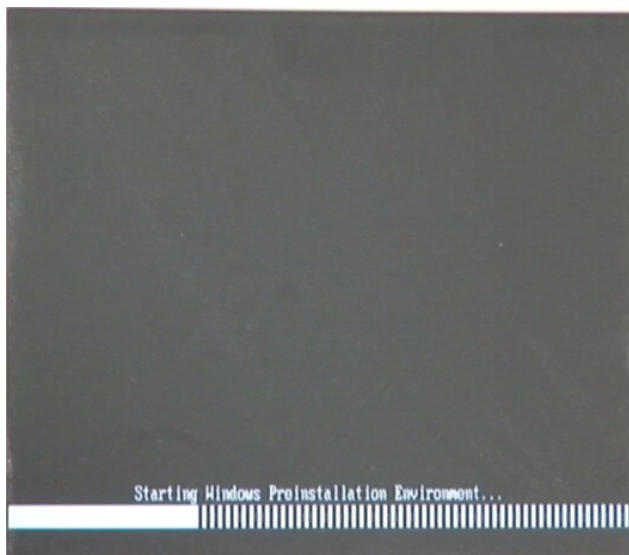

Figure A-2: Launching the Recovery Tool

**Step 3:** The recovery tool setup menu is shown as below.

```

C:\X:\I386\system32\cmd.exe
1.Ghost Execution
2.System Configuration For Windows
3.System Configuration For Linux
4.Exit
5.CMD
Type the number to print text._
  
```

Figure A-3: Recovery Tool Setup Menu

**Step 4:** Press <5> then <Enter>.

```

C:\X:\I386\system32\cmd.exe
1.Ghost Execution
2.System Configuration For Windows
3.System Configuration For Linux
4.Exit
5.CMD
Type the number to print text.5
  
```

Figure A-4: Command Mode

**Step 5:** The command prompt window appears. Type the following commands (marked in red) to create two partitions. One is for the OS installation; the other is for saving recovery files and images which will be an invisible partition.

(Press <Enter> after entering each line below)

```

system32>diskpart
DISKPART>list vol
DISKPART>sel disk 0
DISKPART>create part pri size= ____
DISKPART>assign letter=N
DISKPART>create part pri size= ____
DISKPART>assign letter=F
DISKPART>exit
system32>format N: /fs:ntfs /q /y
  
```



system32>format F: /fs:ntfs /q /v:Recovery /y

system32>exit

```
X:\I386\SYSTEM32\CMD.EXE
X:\I386\SYSTEM32>diskpart → Starts the Microsoft disk partitioning tool.
Microsoft DiskPart version 5.2.3790.1830
Copyright (C) 1999-2001 Microsoft Corporation.
On computer: MININT-JUC
DISKPART> list vol → Show partition information
Volume ### Ltr Label Fs Type Size Status Info
-----
Volume 0 X CD_ROM GDFS DUD-ROM 405 MB Healthy Boot
Volume 1 D FAT32 Removeable 3854 MB Healthy
DISKPART> sel disk 0 → Select a disk
Disk 0 is now the selected disk.
DISKPART> create part pri size=2000 → Create partition 1 and assign a size.
This partition is for OS installation.
DiskPart succeeded in creating the specified partition.
DISKPART> assign letter=N → Assign partition 1 a code name (N).
DiskPart successfully assigned the drive letter or mount point.
DISKPART> create part pri size=1800 → Create partition 2 and assign a size.
This partition is for recovery images.
DiskPart succeeded in creating the specified partition.
DISKPART> assign letter=F → Assign partition 2 a code name (F).
DiskPart successfully assigned the drive letter or mount point.
DISKPART> exit → Exit diskpart
X:\I386\SYSTEM32>format n: /fs:ntfs /q /y → Format partition 1 (N) as NTFS format.
The type of the file system is ntfs.
The new file system is NTFS.
QuickFormatting 2000M
Creating file system structures.
Format complete.
2048254 KB total disk space.
2035620 KB are available.
X:\I386\SYSTEM32>format f: /fs:ntfs /q /v:Recovery /y → Formate partition 2 (F) as NTFS formate and
name it as "Recovery".
The type of the file system is ntfs.
The new file system is NTFS.
QuickFormatting 1804M
Creating file system structures.
Format complete.
1847474 KB total disk space.
1835860 KB are available.
X:\I386\SYSTEM32>exit → Exit Windows PE
```

Figure A-5: Partition Creation Commands

**NOTE:**

Use the following commands to check if the partitions were created successfully.

```
X:\I386\SYSTEM32>diskpart
Microsoft DiskPart version 5.2.3790.1830
Copyright (C) 1999-2001 Microsoft Corporation.
On computer: MININT-JUC

DISKPART> sel disk 0
Disk 0 is now the selected disk.

DISKPART> list part

   Partition ###   Type              Size              Offset
-----
   Partition 1     Primary           2000 MB           32 KB
   Partition 2     Primary           1804 MB          2000 MB

DISKPART> exit
```

**Step 6:** Press any key to exit the recovery tool and automatically reboot the system.

Please continue to the following procedure: Build-up Recovery Partition.

### A.2.3 Install Operating System, Drivers and Applications

Install the operating system onto the unlabelled partition. The partition labeled as "Recovery" is for use by the system recovery tool and should not be used for installing the operating system or any applications.

**NOTE:**

The operating system installation program may offer to reformat the chosen partition. DO NOT format the partition again. The partition has already been formatted and is ready for installing the new operating system.

To install the operating system, insert the operating system installation CD into the optical drive. Restart the computer and follow the installation instructions.

## UIBX-200-R11/Z510P Embedded System

### A.2.4 Build-up Recovery Partition

- Step 1:** Put the recover CD in the optical drive.
- Step 2:** Start the system.
- Step 3:** **Boot the system from recovery CD.** When prompted, press any key to boot from the recovery CD. It will take a while to launch the recovery tool. Please be patient!

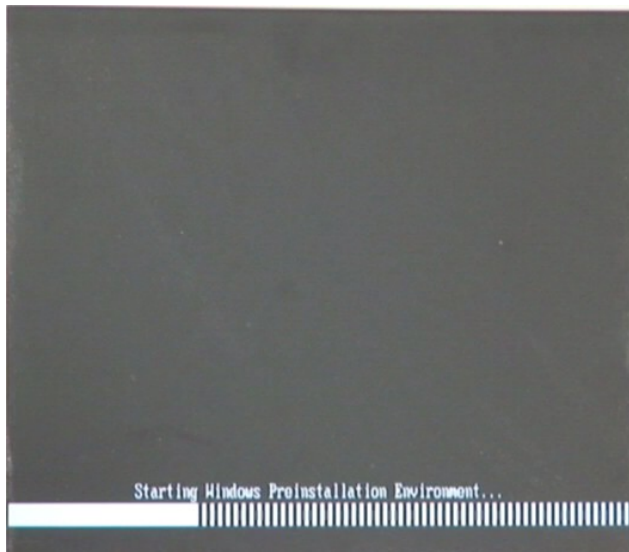

Figure A-6: Launching the Recovery Tool

- Step 4:** When the recovery tool setup menu appears, press <2> then <Enter>.

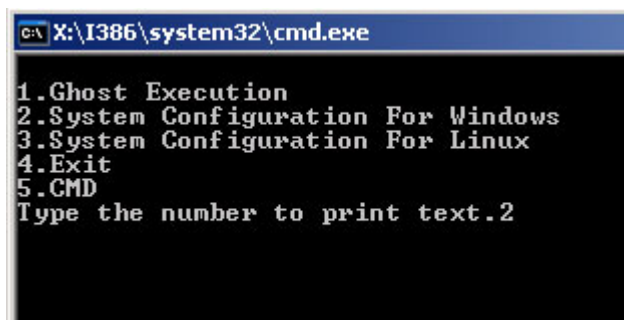
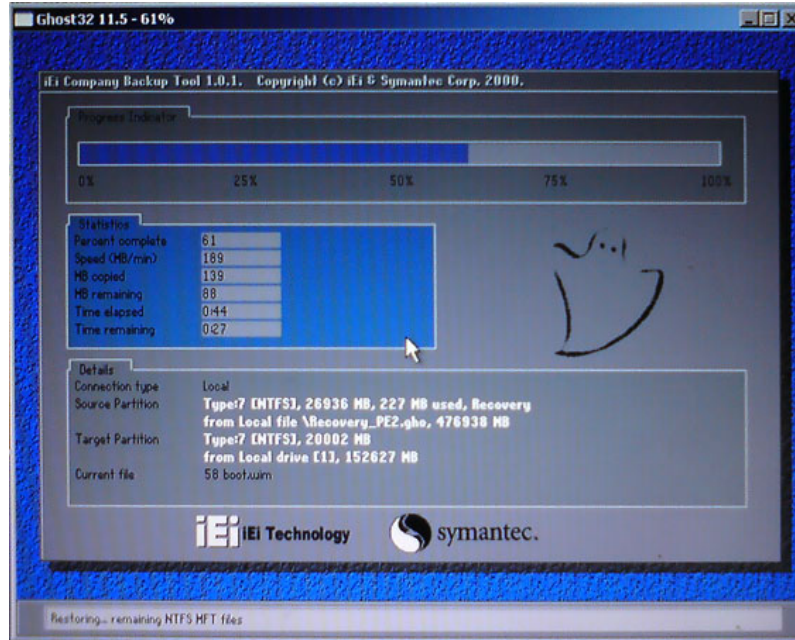

Figure A-7: System Configuration for Windows

- Step 5:** The Symantec Ghost window appears and starts configuring the system to build-up a recovery partition. In this process, the partition which is created for

recovery files in **Section A.2.2** is hidden and the recovery tool is saved in this partition.



**Figure A-8: Build-up Recovery Partition**

**Step 6:** After completing the system configuration, press any key in the following window to reboot the system.

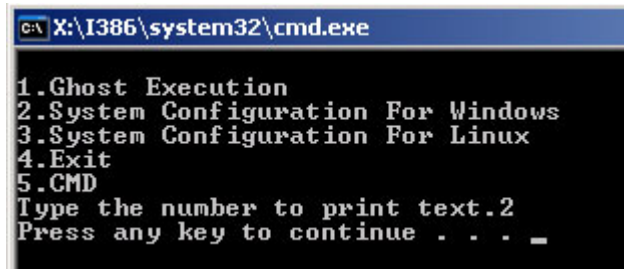

**Figure A-9: Press any key to continue**

**Step 7:** Eject the recovery CD.

## A.2.5 Create Factory Default Image



### NOTE:

Before creating the factory default image, please configure the system to a factory default environment, including driver and application installations.

To create a factory default image, please follow the steps below.

**Step 1:** Turn on the system. When the following screen displays (**Figure A-10**), press the <F3> key to access the recovery tool. The message will display for 10 seconds, please press F3 before the system boots into the operating system.

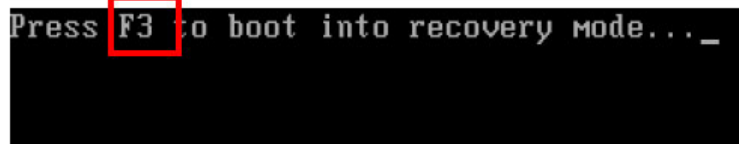

```
Press F3 to boot into recovery mode... _
```

Figure A-10: Press F3 to Boot into Recovery Mode

**Step 2:** The recovery tool menu appears. Type <4> and press <Enter>. (**Figure A-11**)

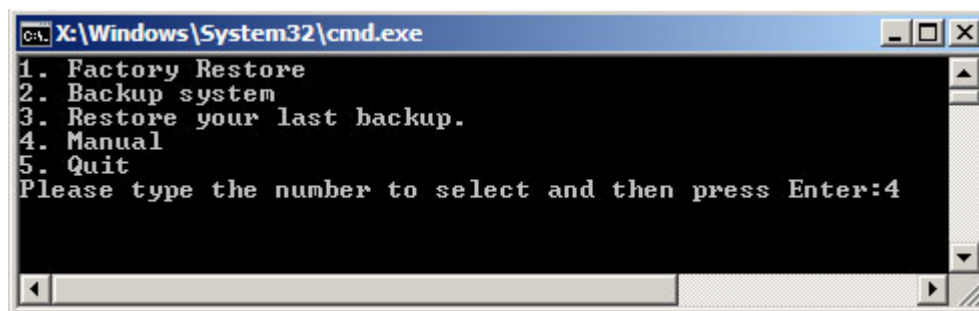

Figure A-11: Recovery Tool Menu

**Step 3:** The About Symantec Ghost window appears. Click **OK** button to continue.

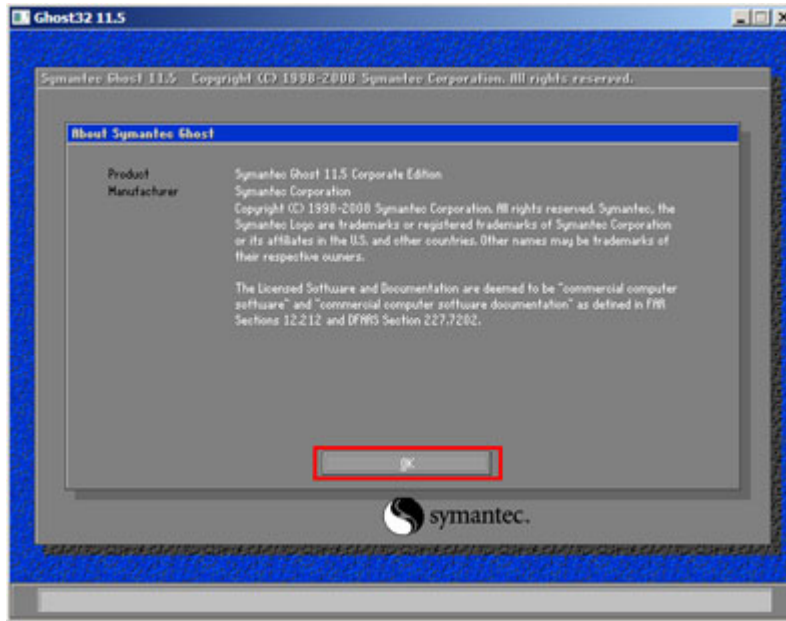

Figure A-12: About Symantec Ghost Window

**Step 4:** Use mouse to navigate to the option shown below (Figure A-13).

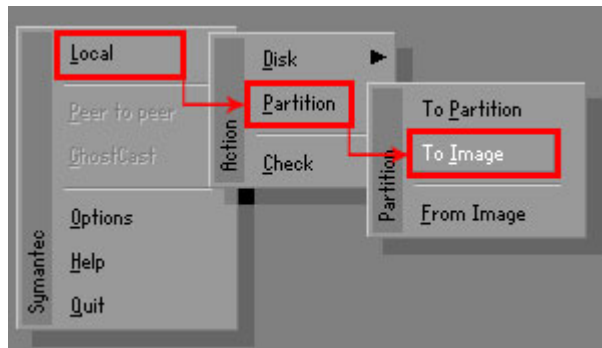

Figure A-13: Symantec Ghost Path

**Step 5:** Select the local source drive (Drive 1) as shown in Figure A-14. Then click OK.

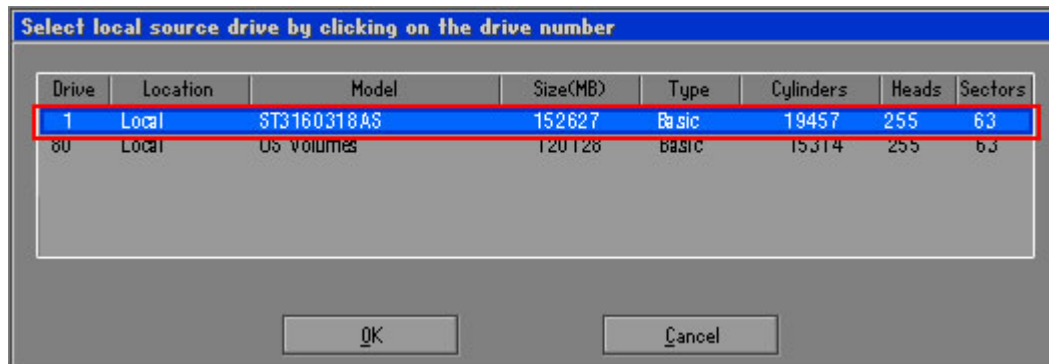

Figure A-14: Select a Local Source Drive

**Step 6:** Select a source partition (Part 1) from basic drive as shown in **Figure A-15**. Then click OK.

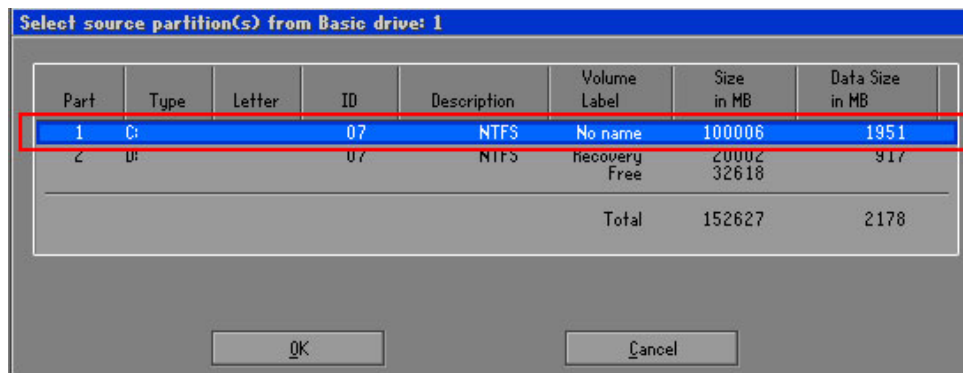

Figure A-15: Select a Source Partition from Basic Drive

**Step 7:** Select **1.2: [Recovery] NTFS drive** and enter a file name called **iei** (**Figure A-16**). Click **Save**. The factory default image will then be saved in the selected recovery drive and named **IEI.GHO**.



**WARNING:**

The file name of the factory default image must be **iei.GHO**.

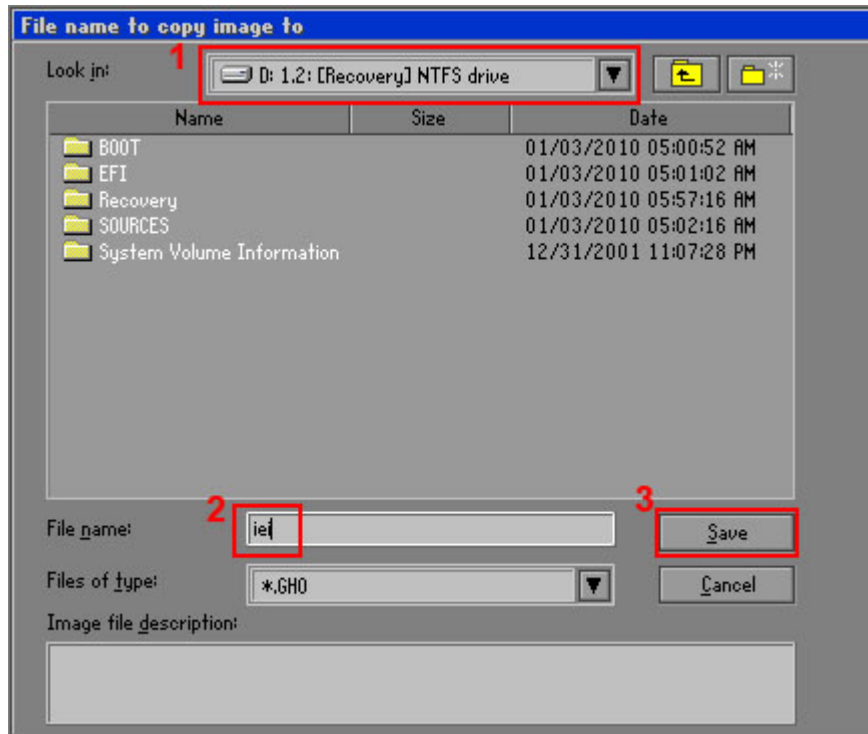

Figure A-16: File Name to Copy Image to

**Step 8:** When the Compress Image screen in **Figure A-17** prompts, click **High** to make the image file smaller.

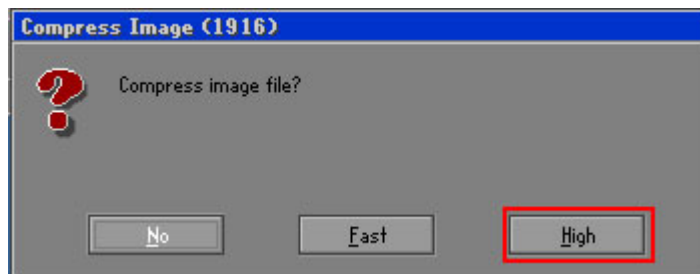
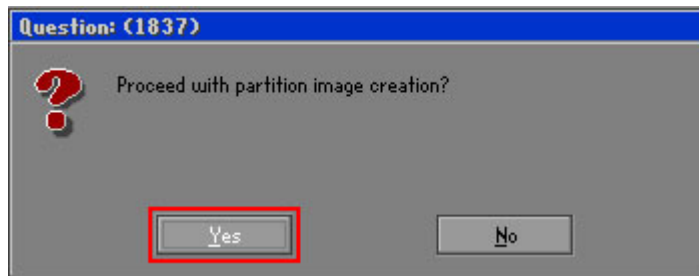

Figure A-17: Compress Image



## UIBX-200-R11/Z510P Embedded System

**Step 9:** The Proceed with partition image creation window appears, click **Yes** to continue.



**Figure A-18: Image Creation Confirmation**

**Step 10:** The Symantec Ghost starts to create the factory default image (**Figure A-19**).

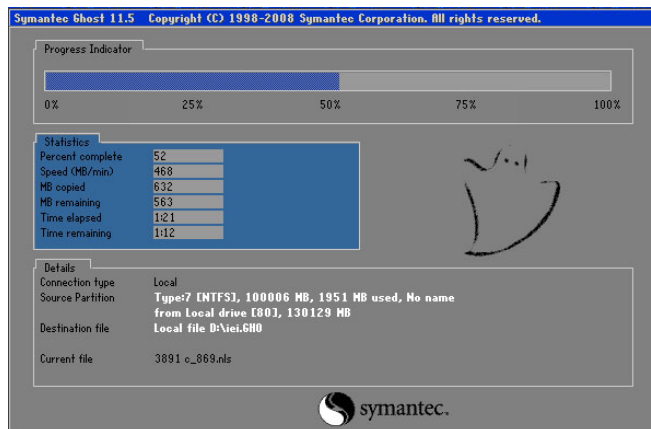

**Figure A-19: Image Creation Process**

**Step 11:** When the image creation completes, a screen prompts as shown in **Figure A-20**.

Click **Continue** and close the Ghost window to exit the program.



**Figure A-20: Image Creation Complete**

**Step 12:** The recovery tool main menu window is shown as below. Press any key to reboot the system.

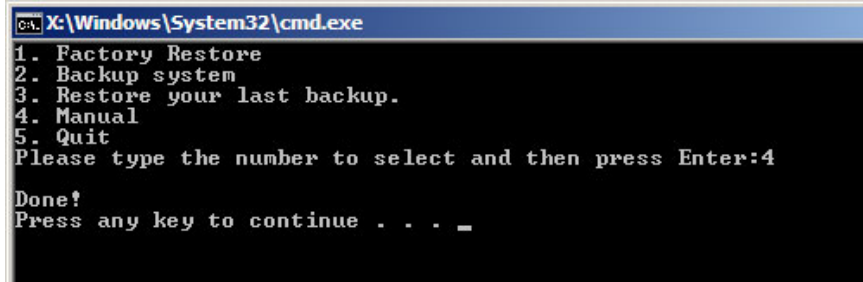

```

C:\Windows\System32\cmd.exe
1. Factory Restore
2. Backup system
3. Restore your last backup.
4. Manual
5. Quit
Please type the number to select and then press Enter:4
Done!
Press any key to continue . . . _
    
```

Figure A-21: Press Any Key to Continue

### A.3 Setup Procedure for Linux

The initial setup procedures for a Linux system are mostly the same with the procedure for Microsoft Windows. Please follow the steps below to setup the recovery tool for Linux OS.

**Step 1: Hardware and BIOS setup.** Refer to **Section A.2.1**.

**Step 2: Install Linux operating system.** Make sure to install GRUB (v0.97 or earlier) MBR type and Ext3 partition type. Leave enough space on the hard drive to create the recover partition later.



#### **NOTE:**

If the Linux OS is not installed with GRUB (v0.97 or earlier) and Ext3, the Symantec Ghost may not function properly.

While installing Linux OS, please create two partitions:

- Partition 1: /
- Partition 2: **SWAP**

**NOTE:**

Please reserve enough space for partition 3 for saving recovery images.

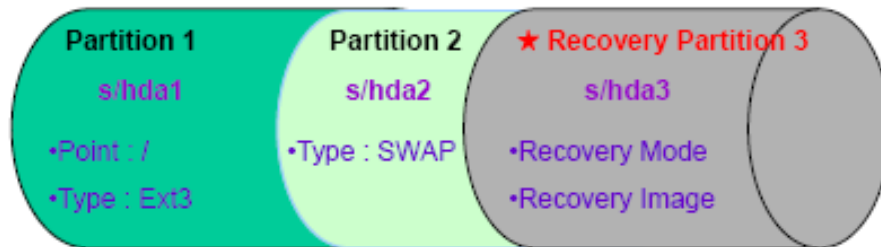

Figure A-22: Partitions for Linux

**Step 3:** Create a recovery partition. Insert the recovery CD into the optical disk drive.

Follow **Step 1 ~ Step 3** described in **Section A.2.2**. Then type the following commands (marked in red) to create a partition for recovery images.

```
system32>diskpart
DISKPART>list vol
DISKPART>sel disk 0
DISKPART>create part pri size= ____
DISKPART>assign letter=N
DISKPART>exit
system32>format N: /fs:ntfs /q /v:Recovery /y
system32>exit
```

**Step 4:** Build-up recovery partition. Press any key to boot from the recovery CD. It will take a while to launch the recovery tool. Please be patient. When the recovery tool setup menu appears, type <3> and press <Enter> (**Figure A-23**). The Symantec Ghost window appears and starts configuring the system to build-up a recovery partition. After completing the system configuration, press any key to reboot the system. Eject the recovery CD.

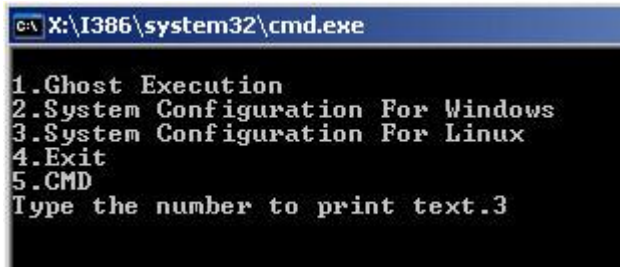

```
C:\X:\I386\system32\cmd.exe
1.Ghost Execution
2.System Configuration For Windows
3.System Configuration For Linux
4.Exit
5.CMD
Type the number to print text.3
```

**Figure A-23: System Configuration for Linux**

**Step 5:** Access the recovery tool main menu by modifying the “menu.lst”. To first access the recovery tool main menu, the menu.lst must be modified. In Linux system, enter Administrator (root). When prompt appears, type:

**cd /boot/grub**

**vi menu.lst**

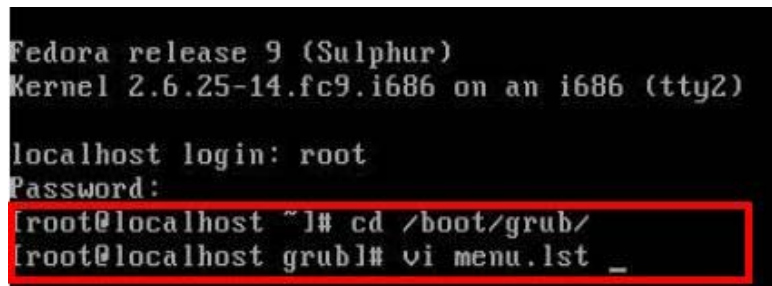

```
Fedora release 9 (Sulphur)
Kernel 2.6.25-14.fc9.i686 on an i686 (tty2)

localhost login: root
Password:
[root@localhost ~]# cd /boot/grub/
[root@localhost grub]# vi menu.lst _
```

**Figure A-24: Access menu.lst in Linux (Text Mode)**

**Step 6:** Modify the menu.lst as shown below.

```
#boot=/dev/sda
default=0
timeout=10 ← Modify timeout=10
splashimage=(hd0,0)/grub/splash.xpm.gz
hiddenmenu
title Fedora (2.6.25-14.fc9.i686)
    root (hd0,0)
    kernel /vmlinuz-2.6.25-14.fc9.i686 ro root=UUID=10f1acd
ac38b5c78910 rhgb quiet
    initrd /initrd-2.6.25-14.fc9.i686.img

title Recovery Partition
root (hd0,2)
makeactive ← Type command
chainloader +1
```

- Type command:  
**title Recovery Partition**  
**root (hd0,2)**  
**makeactive**  
**chainloader +1**

**Step 7:** The recovery tool menu appears. (Figure A-25)

```
1. Factory Restore
2. Backup system
3. Restore your last backup.
4. Manual
5. Quit
Please type the number to select and then press Enter:
```

Figure A-25: Recovery Tool Menu

**Step 8:** Create a factory default image. Follow **Step 2 ~ Step 12** described in **Section A.2.5** to create a factory default image.

## A.4 Recovery Tool Functions

After completing the initial setup procedures as described above, users can access the recovery tool by pressing **<F3>** while booting up the system. The main menu of the recovery tool is shown below.

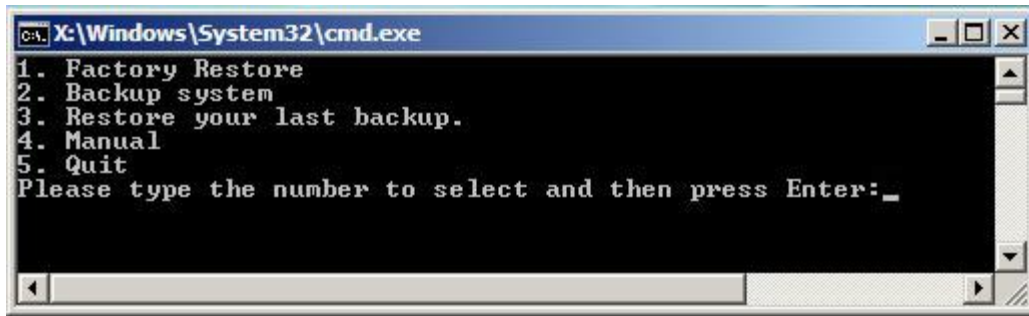

**Figure A-26: Recovery Tool Main Menu**

The recovery tool has several functions including:

1. **Factory Restore:** Restore the factory default image (iei.GHO) created in Section A.2.5.
2. **Backup system:** Create a system backup image (iei\_user.GHO) which will be saved in the hidden partition.
3. **Restore your last backup:** Restore the last system backup image
4. **Manual:** Enter the Symantec Ghost window to configure manually.
5. **Quit:** Exit the recovery tool and restart the system.



**WARNING:**

Please do not turn off the system power during the process of system recovery or backup.



**WARNING:**

All data in the system will be deleted during the system recovery. Please backup the system files before restoring the system (either Factory Restore or Restore Backup).

## UIBX-200-R11/Z510P Embedded System

### A.4.1 Factory Restore

To restore the factory default image, please follow the steps below.

**Step 1:** Type <1> and press <Enter> in the main menu.

**Step 2:** The Symantec Ghost window appears and starts to restore the factory default. A factory default image called **iei.GHO** is created in the hidden Recovery partition.

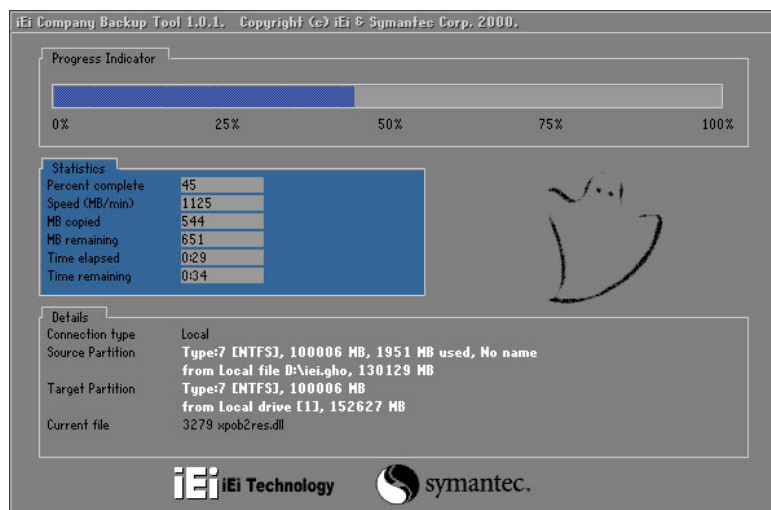

Figure A-27: Restore Factory Default

**Step 3:** The screen is shown as in **Figure A-28** when completed. Press any key to reboot the system.

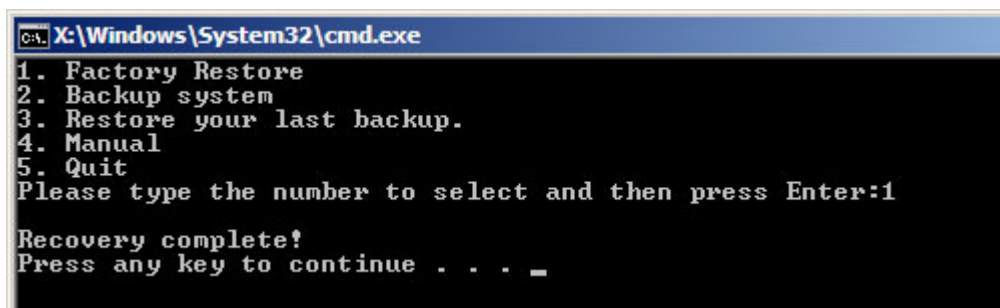

Figure A-28: Recovery Complete Window

### A.4.2 Backup System

To backup the system, please follow the steps below.

**Step 1:** Type <2> and press <Enter> in the main menu.

**Step 2:** The Symantec Ghost window appears and starts to backup the system. A backup image called `iei_user.GHO` is created in the hidden Recovery partition.

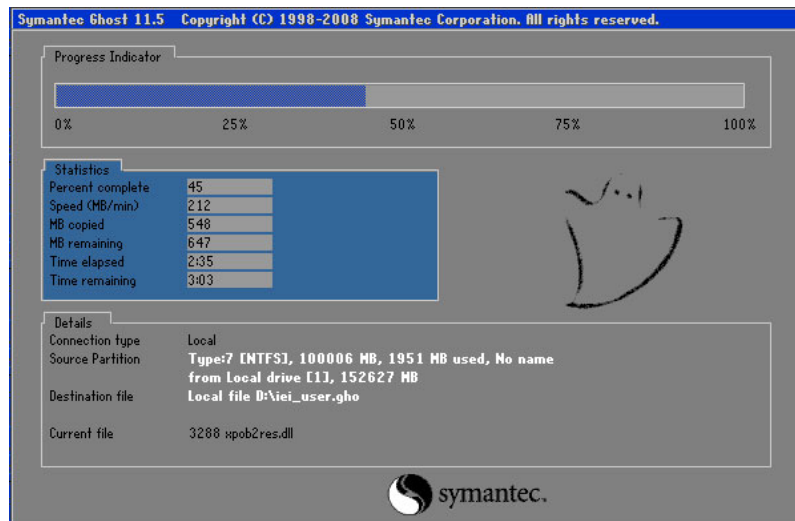

**Figure A-29: Backup System**

**Step 3:** The screen is shown as in **Figure A-30** when system backup is completed.

Press any key to reboot the system.

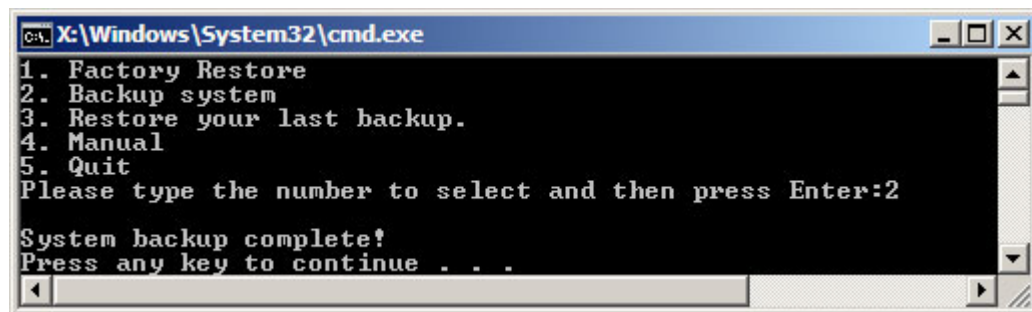

**Figure A-30: System Backup Complete Window**



## UIBX-200-R11/Z510P Embedded System

### A.4.3 Restore Your Last Backup

To restore the last system backup, please follow the steps below.

**Step 1:** Type <3> and press <Enter> in the main menu.

**Step 2:** The Symantec Ghost window appears and starts to restore the last backup image (iei\_user.GHO).

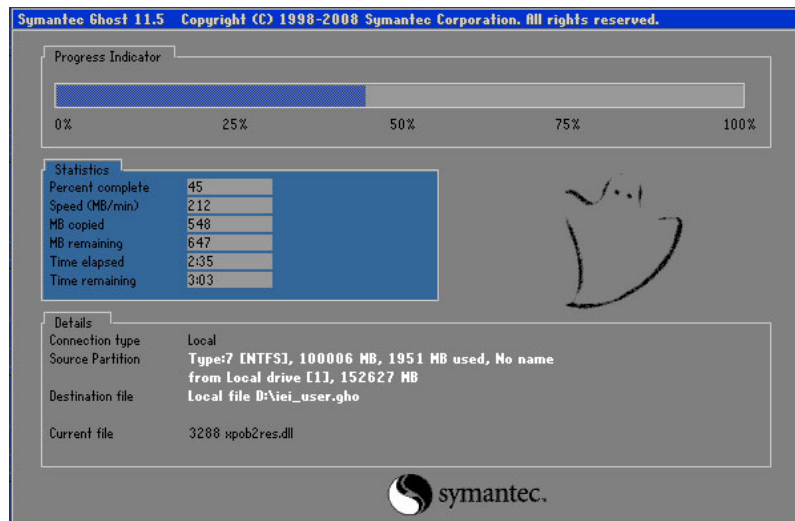

Figure A-31: Restore Backup

**Step 3:** The screen is shown as in **Figure A-32** when backup recovery is completed. Press any key to reboot the system.

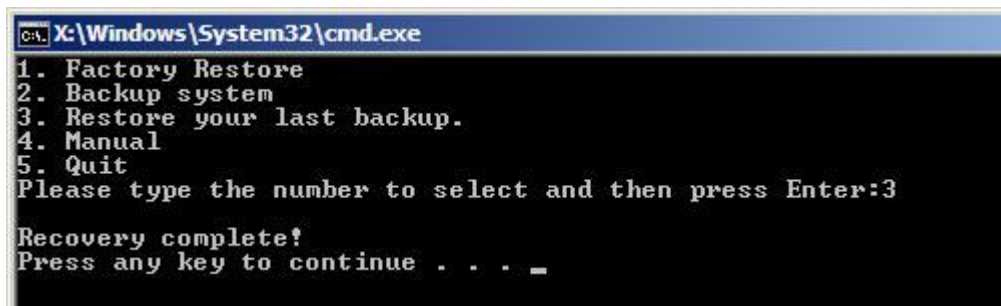

Figure A-32: Restore System Backup Complete Window

#### A.4.4 Manual

To restore the last system backup, please follow the steps below.

**Step 1:** Type <4> and press <Enter> in the main menu.

**Step 2:** The Symantec Ghost window appears. Use the Ghost program to backup or recover the system manually.

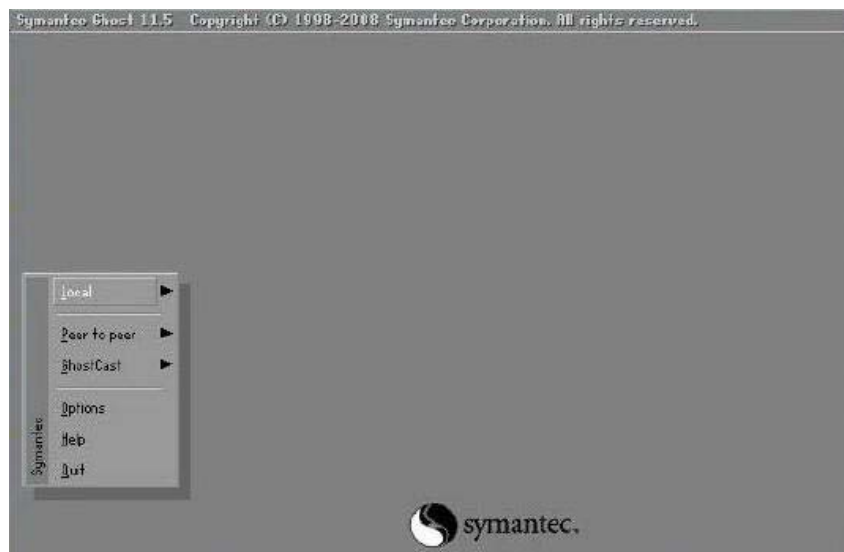

Figure A-33: Symantec Ghost Window

**Step 3:** When backup or recovery is completed, press any key to reboot the system.

## A.5 Other Information

### A.5.1 Using AHCI Mode or ALi M5283 / VIA VT6421A Controller

When the system uses AHCI mode or some specific SATA controllers such as ALi M5283 or VIA VT6421A, the SATA RAID/AHCI driver must be installed before using one key recovery. Please follow the steps below to install the SATA RAID/AHCI driver.

- Step 1:** Copy the SATA RAID/AHCI driver to a floppy disk and insert the floppy disk into a USB floppy disk drive. The SATA RAID/AHCI driver must be especially designed for the on-board SATA controller.
- Step 2:** Connect the USB floppy disk drive to the system.
- Step 3:** Insert the One Key Recovery CD into the system and boot the system from the CD.
- Step 4:** When launching the recovery tool, press <F6>.

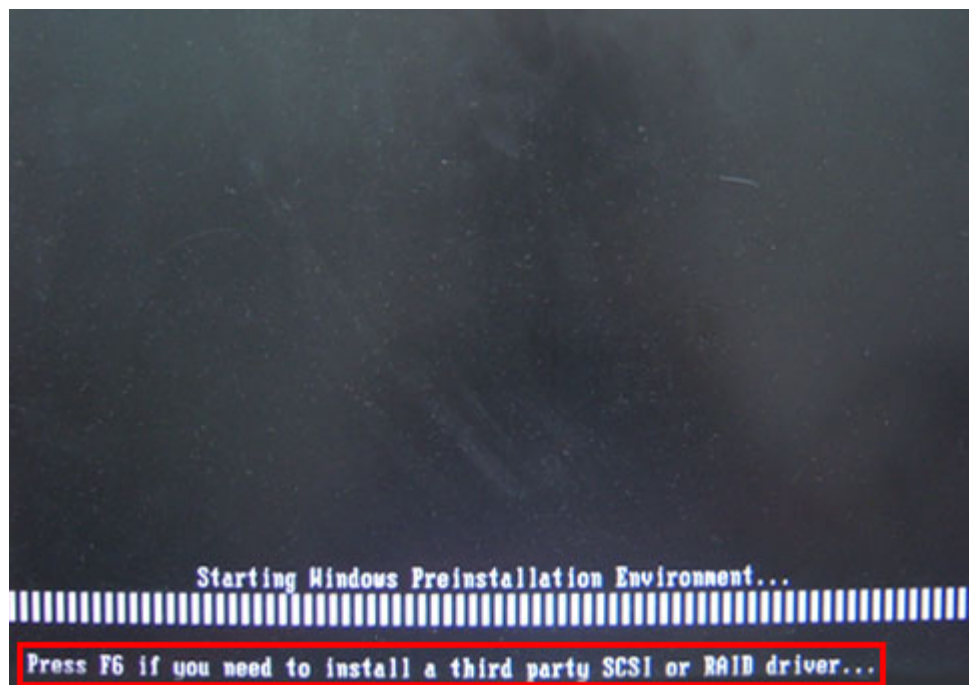

**Step 5:** When the following window appears, press <S> to select “Specify Additional Device”.

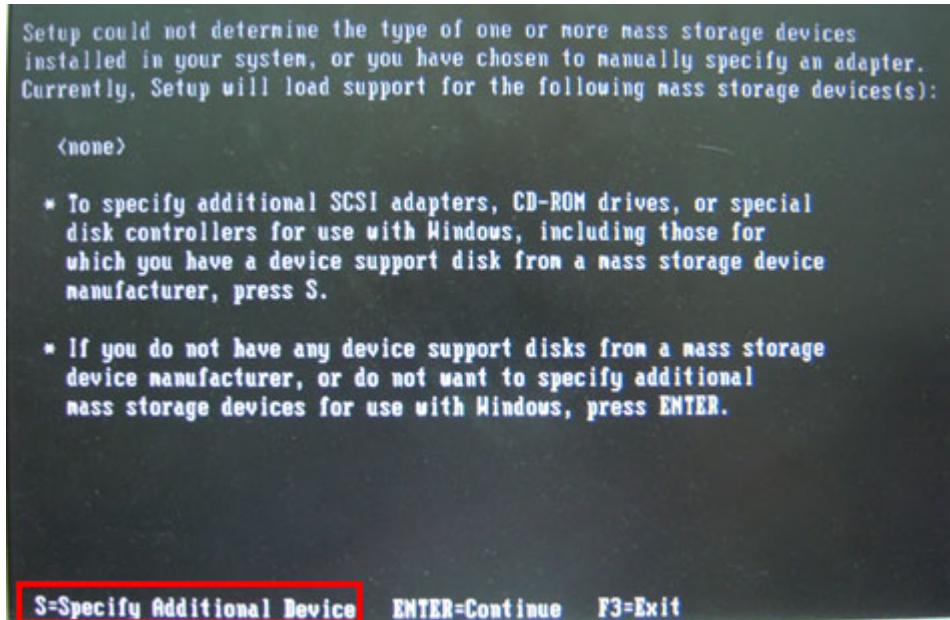

**Step 6:** In the following window, select a SATA controller mode used in the system. Then press <Enter>. The user can now start using the SATA HDD.

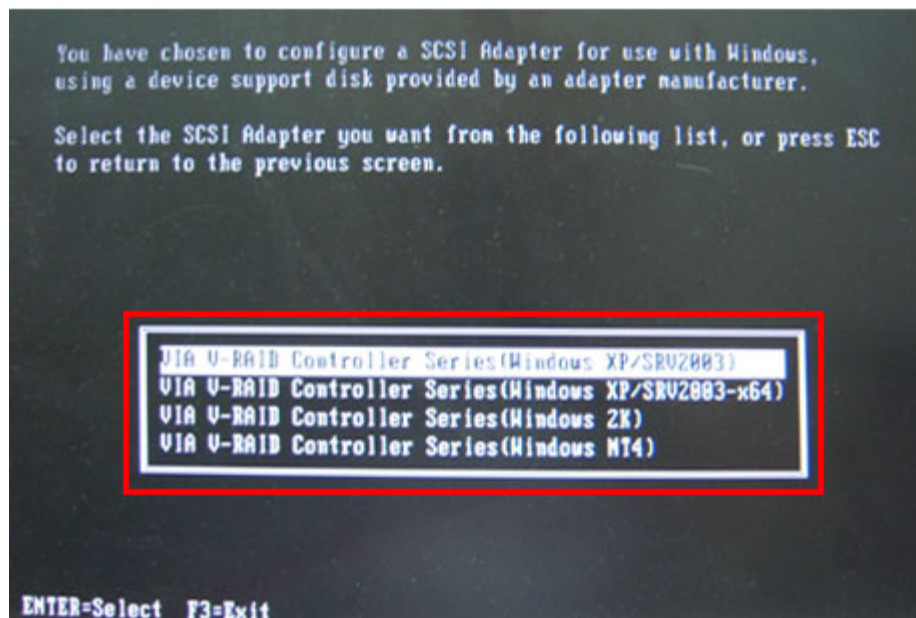

## UIBX-200-R11/Z510P Embedded System

**Step 7:** After pressing <Enter>, the system will get into the recovery tool setup menu.

Continue to follow the setup procedure from **Step 4** in **Section A.2.2 Create Partitions** to finish the whole setup process.

### A.5.2 System Memory Requirement

To be able to access the recovery tool by pressing <F3> while booting up the system, please make sure to have enough system memory. The minimum memory requirement is listed below.

- **Using Award BIOS:** 128 MB system memory
- **Using AMI BIOS:** 512 MB system memory.

Appendix

**B**

# Safety Precautions

---

## B.1 Safety Precautions

---



### WARNING:

The precautions outlined in this appendix should be strictly followed. Failure to follow these precautions may result in permanent damage to the UIBX-200-R11/Z510P.

---

Please follow the safety precautions outlined in the sections that follow:

### B.1.1 General Safety Precautions

Please ensure the following safety precautions are adhered to at all times.

- ***Make sure the power is turned off and the power cord is disconnected*** when moving, installing or modifying the system.
- ***Do not apply voltage levels that exceed the specified voltage range.*** Doing so may cause fire and/or an electrical shock.
- ***Electric shocks can occur*** if opened while still powered on.
- ***Do not drop or insert any objects*** into the ventilation openings.
- ***If considerable amounts of dust, water, or fluids enter the system***, turn off the power supply immediately, unplug the power cord, and contact the system vendor.
- **DO NOT:**
  - Drop the system against a hard surface.
  - Strike or exert excessive force onto the LCD panel.
  - Touch any of the LCD panels with a sharp object
  - In a site where the ambient temperature exceeds the rated temperature

### B.1.2 Anti-static Precautions

---



#### WARNING:

Failure to take ESD precautions during the installation of the UIBX-200-R11/Z510P may result in permanent damage to the UIBX-200-R11/Z510P and severe injury to the user.

---

Electrostatic discharge (ESD) can cause serious damage to electronic components, including the UIBX-200-R11/Z510P. Dry climates are especially susceptible to ESD. It is therefore critical that whenever the UIBX-200-R11/Z510P is opened and any of the electrical components are handled, the following anti-static precautions are strictly adhered to.

- ***Wear an anti-static wristband:*** Wearing a simple anti-static wristband can help to prevent ESD from damaging any electrical component.
- ***Self-grounding:*** Before handling any electrical component, touch any grounded conducting material. During the time the electrical component is handled, frequently touch any conducting materials that are connected to the ground.
- ***Use an anti-static pad:*** When configuring or working with an electrical component, place it on an anti-static pad. This reduces the possibility of ESD damage.
- ***Only handle the edges of the electrical component:*** When handling the electrical component, hold the electrical component by its edges.



### B.1.3 Product Disposal

---



#### CAUTION:

Risk of explosion if battery is replaced by and incorrect type. Only certified engineers should replace the on-board battery.

Dispose of used batteries according to instructions and local regulations.

---

- Outside the European Union - If you wish to dispose of used electrical and electronic products outside the European Union, please contact your local authority so as to comply with the correct disposal method.
- Within the European Union:



EU-wide legislation, as implemented in each Member State, requires that waste electrical and electronic products carrying the mark (left) must be disposed of separately from normal household waste. This includes monitors and electrical accessories, such as signal cables or power cords.

When you need to dispose of your display products, please follow the guidance of your local authority, or ask the shop where you purchased the product. The mark on electrical and electronic products only applies to the current European Union Member States.

Please follow the national guidelines for electrical and electronic product disposal.

## B.2 Maintenance and Cleaning Precautions

When maintaining or cleaning the UIBX-200-R11/Z510P, please follow the guidelines below.

### B.2.1 Maintenance and Cleaning

Prior to cleaning any part or component of the UIBX-200-R11/Z510P, please read the details below.

- Except for the LCD panel, never spray or squirt liquids directly onto any other components. To clean the LCD panel, gently wipe it with a piece of soft dry cloth or a slightly moistened cloth.
- The interior of the UIBX-200-R11/Z510P does not require cleaning. Keep fluids away from the UIBX-200-R11/Z510P interior.
- Be cautious of all small removable components when vacuuming the UIBX-200-R11/Z510P.
- Turn the UIBX-200-R11/Z510P off before cleaning the UIBX-200-R11/Z510P.
- Never drop any objects or liquids through the openings of the UIBX-200-R11/Z510P.
- Be cautious of any possible allergic reactions to solvents or chemicals used when cleaning the UIBX-200-R11/Z510P.
- Avoid eating, drinking and smoking within vicinity of the UIBX-200-R11/Z510P.

## B.2.2 Cleaning Tools

Some components in the UIBX-200-R11/Z510P may only be cleaned using a product specifically designed for the purpose. In such case, the product will be explicitly mentioned in the cleaning tips. Below is a list of items to use when cleaning the UIBX-200-R11/Z510P.

- **Cloth** – Although paper towels or tissues can be used, a soft, clean piece of cloth is recommended when cleaning the UIBX-200-R11/Z510P.
- **Water or rubbing alcohol** – A cloth moistened with water or rubbing alcohol can be used to clean the UIBX-200-R11/Z510P.
- **Using solvents** – The use of solvents is not recommended when cleaning the UIBX-200-R11/Z510P as they may damage the plastic parts.
- **Vacuum cleaner** – Using a vacuum specifically designed for computers is one of the best methods of cleaning the UIBX-200-R11/Z510P. Dust and dirt can restrict the airflow in the UIBX-200-R11/Z510P and cause its circuitry to corrode.
- **Cotton swabs** - Cotton swabs moistened with rubbing alcohol or water are excellent tools for wiping hard to reach areas.
- **Foam swabs** - Whenever possible, it is best to use lint free swabs such as foam swabs for cleaning.

Appendix

C

# Watchdog Timer

---



**NOTE:**

The following discussion applies to DOS environment. IEI support is contacted or the IEI website visited for specific drivers for more sophisticated operating systems, e.g., Windows and Linux.

The Watchdog Timer is provided to ensure that standalone systems can always recover from catastrophic conditions that cause the CPU to crash. This condition may have occurred by external EMIs or a software bug. When the CPU stops working correctly, Watchdog Timer either performs a hardware reset (cold boot) or a Non-Maskable Interrupt (NMI) to bring the system back to a known state.

A BIOS function call (INT 15H) is used to control the Watchdog Timer.

INT 15H:

<b>AH – 6FH Sub-function:</b>	
AL – 2:	Sets the Watchdog Timer’s period.
BL:	Time-out value (Its unit-second is dependent on the item “Watchdog Timer unit select” in CMOS setup).

**Table C-1: AH-6FH Sub-function**

Call sub-function 2 to set the time-out period of Watchdog Timer first. If the time-out value is not zero, the Watchdog Timer starts counting down. When the timer value reaches zero, the system resets. To ensure that this reset condition does not occur, calling sub-function 2 must periodically refresh the Watchdog Timer. However, the watchdog timer is disabled if the time-out value is set to zero.

A tolerance of at least 10% must be maintained to avoid unknown routines within the operating system (DOS), such as disk I/O that can be very time-consuming.



## NOTE:

When exiting a program it is necessary to disable the Watchdog Timer, otherwise the system resets.

## EXAMPLE PROGRAM:

**; INITIAL TIMER PERIOD COUNTER**

;

**W\_LOOP:**

;

```

MOV      AX, 6F02H      ;setting the time-out value
MOV      BL, 30         ;time-out value is 48 seconds
INT      15H

```

;

**; ADD THE APPLICATION PROGRAM HERE**

;

```

CMP      EXIT_AP, 1     ;is the application over?
JNE      W_LOOP        ;No, restart the application

```

```

MOV      AX, 6F02H      ;disable Watchdog Timer
MOV      BL, 0         ;
INT      15H

```

;

**; EXIT ;**

▪



Appendix

D

# Hazardous Materials Disclosure

---

## **D.1 Hazardous Materials Disclosure Table for IPB Products Certified as RoHS Compliant Under 2002/95/EC Without Mercury**

The details provided in this appendix are to ensure that the product is compliant with the Peoples Republic of China (China) RoHS standards. The table below acknowledges the presences of small quantities of certain materials in the product, and is applicable to China RoHS only.

A label will be placed on each product to indicate the estimated “Environmentally Friendly Use Period” (EFUP). This is an estimate of the number of years that these substances would “not leak out or undergo abrupt change.” This product may contain replaceable sub-assemblies/components which have a shorter EFUP such as batteries and lamps. These components will be separately marked.

Please refer to the table on the next page.

Part Name	Toxic or Hazardous Substances and Elements					
	Lead (Pb)	Mercury (Hg)	Cadmium (Cd)	Hexavalent Chromium (CR(VI))	Polybrominated Biphenyls (PBB)	Polybrominated Diphenyl Ethers (PBDE)
<b>Housing</b>	X	O	O	O	O	X
<b>Display</b>	X	O	O	O	O	X
<b>Printed Circuit Board</b>	X	O	O	O	O	X
<b>Metal Fasteners</b>	X	O	O	O	O	O
<b>Cable Assembly</b>	X	O	O	O	O	X
<b>Fan Assembly</b>	X	O	O	O	O	X
<b>Power Supply Assemblies</b>	X	O	O	O	O	X
<b>Battery</b>	O	O	O	O	O	O

O: This toxic or hazardous substance is contained in all of the homogeneous materials for the part is below the limit requirement in SJ/T11363-2006

X: This toxic or hazardous substance is contained in at least one of the homogeneous materials for this part is above the limit requirement in SJ/T11363-2006



## UIBX-200-R11/Z510P Embedded System

此附件旨在确保本产品符合中国 RoHS 标准。以下表格标示此产品中某有毒物质的含量符合中国 RoHS 标准规定的限量要求。

本产品上会附有“环境友好使用期限”的标签，此期限是估算这些物质“不会有泄漏或突变”的年限。本产品可能包含有较短的环境友好使用期限的可替换元件，像是电池或灯管，这些元件将会单独标示出来。

部件名称	有毒有害物质或元素					
	铅 (Pb)	汞 (Hg)	镉 (Cd)	六价铬 (CR(VI))	多溴联苯 (PBB)	多溴二苯 醚 (PBDE)
壳体	X	O	O	O	O	X
显示	X	O	O	O	O	X
印刷电路板	X	O	O	O	O	X
金属螺帽	X	O	O	O	O	O
电缆组装	X	O	O	O	O	X
风扇组装	X	O	O	O	O	X
电力供应组装	X	O	O	O	O	X
电池	O	O	O	O	O	O

O: 表示该有毒有害物质在该部件所有物质材料中的含量均在 SJ/T11363-2006 标准规定的限量要求以下。  
X: 表示该有毒有害物质至少在该部件的某一均质材料中的含量超出 SJ/T11363-2006 标准规定的限量要求。