

NP-6135 Series user manual

1.0

2023-1-6



Distribution list:

Name/ Group	Company
EA	NODKA

Reviews/Approvals:

	Name / Function / Company	Signature
Author:	EA	
Reviewed by:		

History:

Version	Date	Author	Description
1.0.0	2023-1-6	EA	First release.

Table of Contents:

1 Introduction.....	6
1.1 Related Manuals.....	7
1.2 Safety Information.....	7
1.3 Production Description.....	7
2 Product Introduction.....	8
2.1 NP-6135.....	9
2.1.1 Features.....	9
2.1.2 Product Dimension.....	9
2.1.3 Product Specifications.....	10
2.1.4 Description of Interfaces.....	11
2.1.4.1 Power button.....	11
2.1.4.2 Status Leds.....	11
2.1.4.3 USB.....	12
2.1.4.3.1 USB on the front.....	12
2.1.4.3.2 USB2.0 on board.....	13
2.1.4.4 Ethernet.....	13
2.1.4.5 COM Ports.....	14
2.1.4.6 Power.....	14
2.1.4.7 Remote switch.....	15
2.2 NP-6135-H1.....	16
2.2.1 Features.....	16
2.2.2 Product Dimension.....	16
2.2.3 Product Specifications.....	17
2.2.4 Description of Interfaces.....	18
2.2.4.1 PoE LAN.....	18
2.2.4.2 DIO.....	19
2.2.4.2.1 DI.....	19
2.2.4.2.2 DO.....	21
2.2.4.2.3 PWM Light Control.....	21
2.3 NP-6135-JH2.....	24
2.3.1 Features.....	24
2.3.2 Product Dimension.....	24
2.3.3 Product Specifications.....	25
2.3.4 Description of Interfaces.....	26
2.3.4.1 PoE LAN.....	26
2.3.4.2 DIO.....	27
2.3.4.2.4 DI.....	27
2.3.4.2.5 DO.....	29
2.3.4.2.6 PWM Light Control.....	29
2.4 NP-6135-H1B.....	32
2.4.1 Features.....	32
2.4.2 Product Dimension.....	32
2.4.3 Product Specifications.....	33
2.4.4 Description of Interfaces.....	34
2.4.4.1 PoE LAN.....	34
2.4.4.2 DIO.....	35
2.4.4.2.1 DI.....	35
2.4.4.2.2 DO.....	36
2.5 NP-6135-JH2B.....	37
2.5.1 Features.....	37
2.5.2 Product Dimension.....	37
2.5.3 Product Specifications.....	38

2.5.4 Description of Interfaces	39
2.5.4.1 PoE LAN	39
2.5.4.2 DIO	40
2.5.4.2.1 DI	40
2.5.4.2.2 DO	41
2.6 NP-6135-JH3	42
2.6.1 Key Features	42
2.6.2 Product Dimension	42
2.6.3 Product Specifications	43
2.6.4 Description of Interfaces	44
2.6.4.1 Lout interface	44
2.6.4.2 USB interface	44
2.6.4.3 COM Ports	45
2.6.4.4 CAN Bus	45
2.6.4.5 DIO	46
2.6.4.5.3 DI	46
2.6.4.5.4 DO	47
2.7 NP-6135-JH4	49
2.7.1 Key Features	49
2.7.2 Product Dimension	49
2.7.3 Product Specifications	50
2.7.4 Description of Interfaces	51
2.7.4.1 RS485 COM Port	51
2.7.4.2 IO Signal terminals	52
2.7.4.2.1 DI	53
2.7.4.2.2 DO	54
2.7.4.2.3 Modbus RTU Register Definitions	55
2.8 NP-6135-8PoE	59
2.8.1 Key Features	59
2.8.2 Product Dimension	59
2.8.3 Product Specifications	60
2.8.4 Description of Interfaces	61
2.8.4.1 PoE LAN	61
2.9 NP-6135-L2	63
2.9.1 Key Features	63
2.9.2 Product Dimension	63
2.9.3 Product Specifications	64
2.9.4 Description of Interfaces	65
2.9.4.1 LAN	65
2.10 NP-6135-CAN2	66
2.10.1 Key Features	66
2.10.2 Product Dimension	66
2.10.3 Product Specifications	67
2.10.4 Description of Interfaces	68
2.10.4.1 CAN Bus	68
3 System Setup	69
3.1.1 Hardware Setup	70
3.1.1.1 Attaching wall-mounted part	70
3.1.1.2 Attaching DIN-Rail mounted part	70
3.1.1.3 SSD Setup	71
3.1.1.4 MiniPICE Setup	72
3.1.1.5 USB dongle Setup	72
3.1.1.6 Fan Setup	73
3.1.2 Driver Setup	73
4 Safety and Maintenance	74

4.1 Safety Precautions.....	75
4.1.1 General Safety Precautions	75
4.1.2 ESD Precautions	75
4.1.3 Product Disposal	75
4.2 Maintenance and Cleaning Precautions.....	75
4.2.1 Maintenance and Cleaning	76
4.2.2 Cleaning Tools	76
5 Q&A	77
5.1 Digital IO Electrical Wiring Diagram	78
5.1.1 Remote Electrical Wiring Diagram	78
5.1.2 H1/JH2 Electrical Wiring Diagram.....	78
5.1.2.1 DI Electrical Wiring Diagram.....	78
5.1.2.2 DO Electrical Wiring Diagram.....	78
5.1.2.3 Light Control Electrical Wiring Diagram.....	79
5.1.2.4 Light Control External Hard Trigger Electrical Wiring Diagram.....	79
5.1.3 H1B/JH2B Electrical Wiring Diagram	79
5.1.3.1 DI Electrical Wiring Diagram.....	79
5.1.3.2 DO Electrical Wiring Diagram	80
5.1.4 JH3 Electrical Wiring Diagram	80
5.1.4.1 DI Electrical Wiring Diagram.....	80
5.1.4.2 DO Electrical Wiring Diagram	80
5.1.5 JH4 Electrical Wiring Diagram	81
5.1.5.1 DI Electrical Wiring Diagram.....	81
5.1.5.2 DO Electrical Wiring Diagram	81
5.2 How to test the DO using multimeter.....	81
5.3 Technical Support and Services.....	81

1 Introduction

This chapter provides necessary information of the product such as the features and manuals before actual use.



1.1 Related Manuals

The manuals related to the product are listed below, please read them as necessary along with this document before actual use.

Name	Purpose	Contents	How to get
User manual	Must read when operating the product.	Describes the hardware features and settings	Download from Nodka website.
SDK user manual	Must read when developing the IO functions	Describes the API functions and usage	Download from Nodka website.

1.2 Safety Information

This document provides safety information using the following symbols to prevent accidents resulting in injury or death and the destruction of equipment and resources. Understand the meanings of these symbols to operate the equipment safely.

Symbol	Description
	WARNING WARNING indicates a potentially hazardous situation which, if not avoided, could result in death or serious injury.
	DANGER DANGER indicates an imminently hazardous situation which, if not avoided, will result in death or serious injury.
	NOTE NOTE provide the reader with additional information or refer to detailed sources of information.

1.3 Production Description

NP-6135 series is a high-performance book-type embedded industrial computer used in the field of automation and machine vision etc. It supports Intel® Core™, Intel Core 10th/11th Generation i3/i5/i7/i9 and Pentium LGA1200 socket type CPU. The product uses a solid aluminum alloy and full sealed housing. The fan is embedded in the separately space to make sure the good cooling system.

NP-6135 series is the COMLAC modular design which consists of CPU module, carrier board and add-on board, the add-on board is also very flexible to be customized to fit the special requirement.

- The independent CPU module is convenient for replacement and upgrade according to particular requirement, as well as cost down control.
- Customised functional add-on boards according to your particular demands.

NP-6135 series are widely used in the field of 3C manufacturing, pharmaceuticals, packaging, mechanical inspection equipment, robotics, motion control, intelligent transportation and so on.

2 Product Introduction

This chapter describes product component and their functions, pin assignment of each connector in detail.

2.1 NP-6135

The NP-6135 is a basic model which support Intel the 10th/10th Generation core i3/i5/i7/i9, Pentium and Celeron LGA1200 socket type desktop high performance processors, two Intel Gigabit LAN onboard, two DB9 serial ports, four USB ports, and are widely used in vision control, robot control, motion control, intelliGent gateway and other automation control fields.

2.1.1 Features

- ◆ 2 x Intel GbE LAN controller
- ◆ 4 x USB 3.0, 1x USB 2.0 Type-A onboard for dongle
- ◆ 2 x RS232/485, RS485 supports automatic data flow control
- ◆ VGA and HDMI dual display ports
- ◆ 1 x miniPCIe slot can be extended to Wifi, 3G/4G
- ◆ Support Wall-mounted or DIN-Rail mounted
- ◆ -20 ~ 60°C wide temperature environment

2.1.2 Product Dimension

Unit: mm

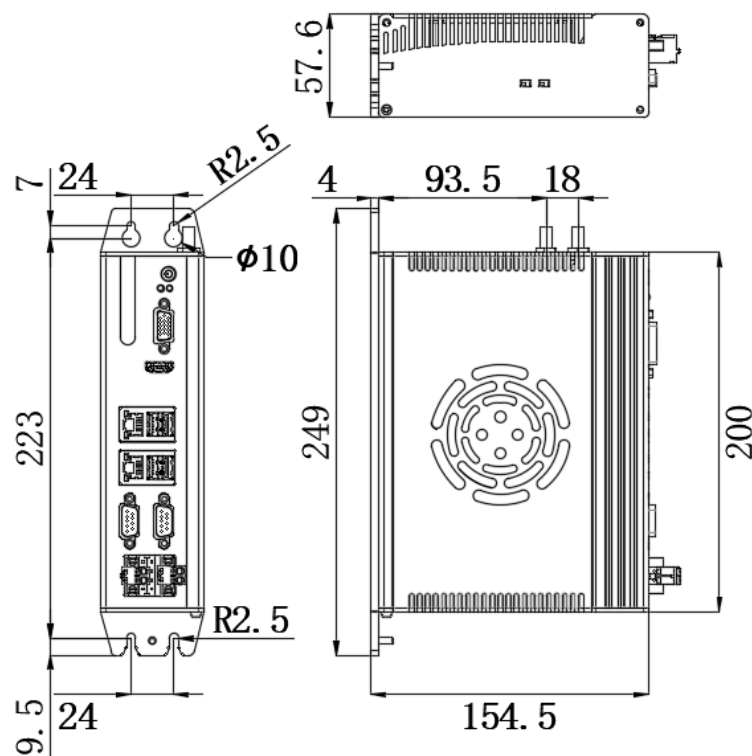

Figure 1 Dimension of NP-6135

2.1.3 Product Specifications

Model Name		NP-6135
System	CPU	Intel® Core™ 10th/11th gen i9/i7/i5/i3 LGA1200 type CPU
	TDP	Max. 65W
	BIOS	AMI UEFI 64Mbit
	Memory	2 x SO-DIMM DDR4, max up to 32GB
	Storage	1 x mSATA bay
		1 x M.2(B Key, Type 2280) bay support SATA
	USB	4 x USB3.0, 1 x USB2.0 Type A on the board for USB dongle
	COM	2 x COM(DB-9), selectable to support RS232 or RS485 mode by the switch, RS485 support auto flow control, (ESD protection for RS232: Air gap ±8KV, Contact ±6KV)
	Ethernet	2 x Intel GbE LAN controller
	VGA	Support up to 1920 x 1200 @ 60Hz
	HDMI	Support up to 3840 x 2160 @ 60Hz
	Expansions	1 x Full-size PCIe Mini slot with SIM card holder(with USB signal)
	Watch Dog	1~255 levels programmable
OS Support	Microsoft Windows	Windows 10
	Linux	Ubuntu, CentOS, Debian
Power	Voltage Input	DC12~24V ±10%, overcurrent, overvoltage and polarity inverse protection
	Power Consumption	Max. 120W
Chassis	Structure	Aluminum-magnesium alloy BOX with fan embedded to assist cooling, Wall-mounted or DIN-Rail fixing style.
	Dimensions	(L)200mm x (W)154.5mm x (H)57.6mm
	Net Weight	1.9Kg
Environment	Work Temperature	-20°C ~ 60°C (-4°F~140°F) with air flow (SSD)
	Storage Temperature	-40°C ~ 80°C (-40°F ~ 176°F) with air flow (SSD)
	Relative Humidity	5~95% (Non-condensing)
	Operating Vibration	5~500Hz, 1.5Grms@with SSD, Follow IEC60068-2-64
	Operating Shock	20G peak acceleration(11ms duration) with SSD, Follow IEC60068-2-27
	EMC	CE/FCC Class A

2.1.4 Description of Interfaces

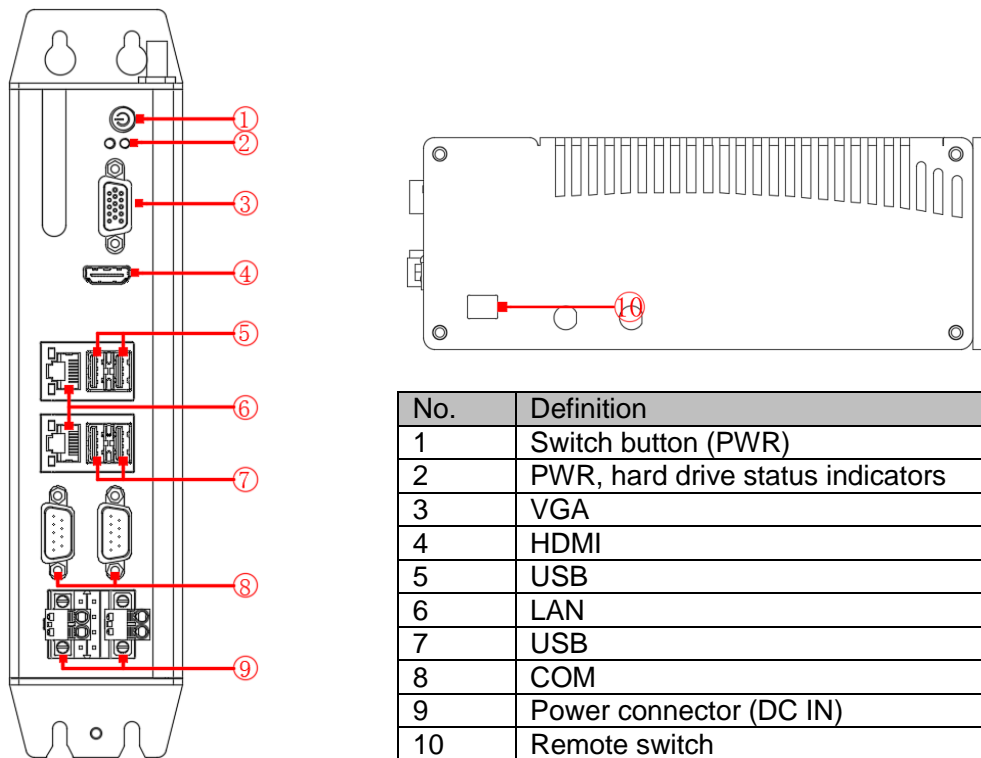

Figure 2 Interfaces of NP-6135

2.1.4.1 Power button

The product provides a power button with power led on the front, which can be used to turn on or turn off the PC in the case of power supply is connected.

2.1.4.2 Status Leds

The product provides two status leds on the front to indicate the status of the power and the storage disk operation.

LED	Status	Description
Power Led	off	The product is power on
	on(Green)	The product is power off
Disk Led	blink(Orange)	The disk is reading or writing

1.1.1.1 Display ports

NP-6135 supports both VGA and HDMI display ports.

■ Pin definition of VGA connector:

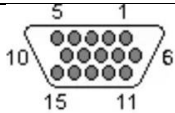
DB-15 Connector			
Pin No.	Signal	Pin No.	Signal
1	RED	2	GREEN
3	BLUE	4	N.C.
5	GND	6	RGND
7	GGND	8	BGND
9	+5V	10	GND
11	N.C.	12	SDA
13	H SYNC	14	V SYNC
15	SCL		

■ Pin definition of HDMI connector:

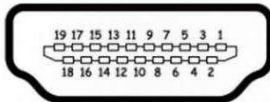
HDMI TYPE-A Connector			
Pin No.	Signals	Pin No.	Signals
1	TMDS DATA 2+	11	TMDS CLOCK SHIELD
2	TMDS DATA 2 SHIELD	12	TMDS CLOCK-
3	TMDS DATA 2-	13	CEC
4	TMDS DATA 1+	14	N.C.
5	TMDS DATA 1 SHIELD	15	DDC CLOCK
6	TMDS DATA 1-	16	DDC DATA
7	TMDS DATA 0+	17	GND
8	TMDS DATA 0 SHIELD	18	+5V PWR
9	TMDS DATA 0-	19	HOT PLUG DETECT
10	TMDS CLOCK+		

2.1.4.3 USB

The product provides four USB TYPE-A ports on the front and one USB TYPE-A port on the board can be used to install USB dongle.

2. 1. 4. 3. 1 USB on the front

NP-6135 provides four USB3.0 ports on the front.

■ Pin definition of USB3.0 port:

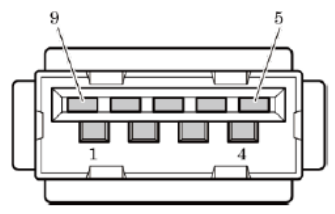
	Pin No.	Signals
	1	VCC5
2	DATA-	
3	DATA+	
4	GND	
5	SSRX-	
6	SSRX+	
7	GND	
8	SSTX-	
9	SSTX+	

■ Pin definition of USB2.0 port:

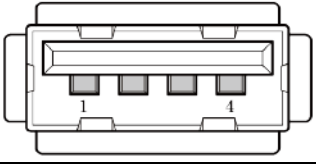
	Pin No.	Signals
	1	VCC5
	2	DATA-
	3	DATA+
	4	GND

2.1.4.3.2 USB2.0 on board

The product provides a USB2.0 on board which can be used for USB dongle. When installing the dongle, you need to open the fan cover according to the following instructions.

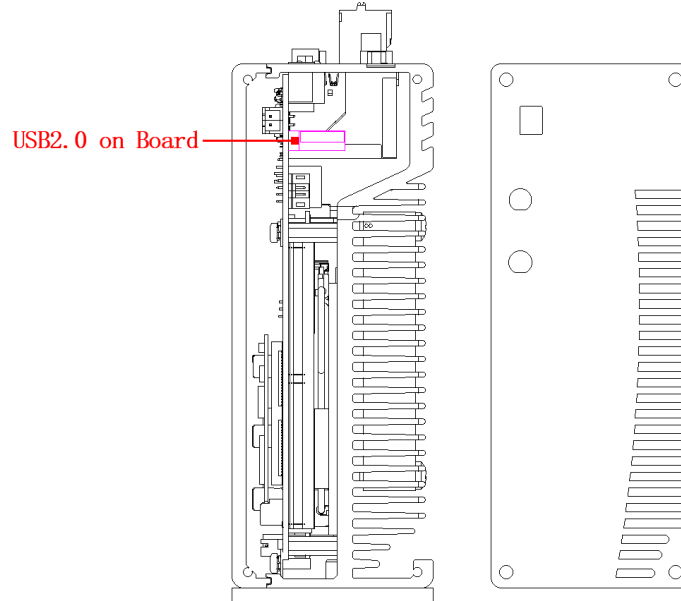
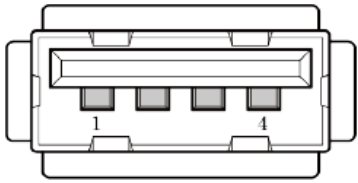

Figure 3 USB2.0 on board

■ Pin definition of USB2.0 port on board:

	Pin No.	Signals
	1	VCC5
	2	DATA-
	3	DATA+
	4	GND

2.1.4.4 Ethernet

The product provides two GbE Lan controllers using standard RJ45 connectors, they are LAN1, LAN2.

■ Pin definition of RJ45 connector:

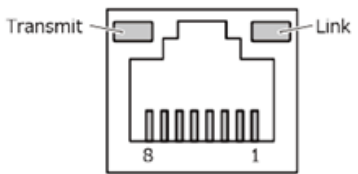
	Pin No.	Signals	
		100BASE-TX	1000BASE-T
	1	TX+	TRD+(0)
	2	TX-	TRD-(0)
	3	RX+	TRD+(1)
	4	N.C.	TRD+(2)
	5	N.C.	TRD-(2)
	6	RX-	TRD-(1)
	7	N.C.	TRD+(3)
8	N.C.	TRD-(3)	

There are two status leds in the RJ45 connector indicate the status of the link and transmit separately. Link led is on when link successfully, and when the network is working in the 1000Mbps, the transmit led is blinking in orange color and in green color when working in the other speed.

Items	Parameters
Network type	1000BASE-T/100BASE-TX/10BASE-T
Transmission speed*	1000M/100M/10M bps
Max. network path length	100m/segment

* Operation at 1000Mbps requires a category 5e or greater cable.

2.1.4.5 COM Ports

NP-6135 has two COM ports(DB9 male terminal) on the front, they are COM 1 and COM 2. Both COMs can support RS232 or RS485 (selected through the DIP switch).

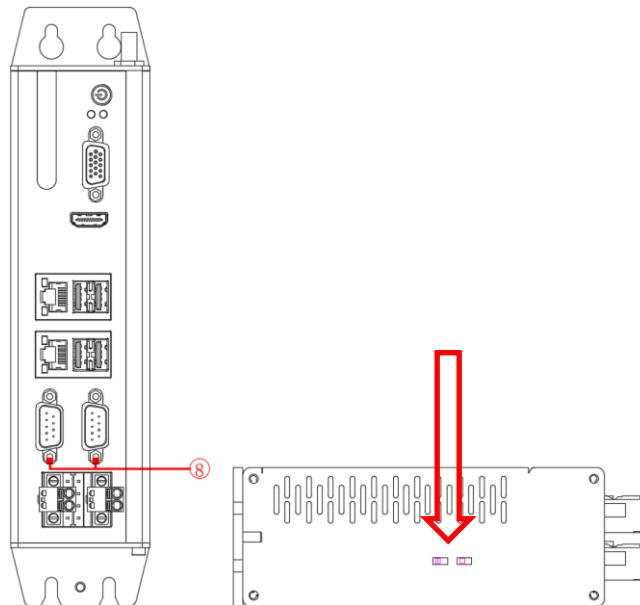
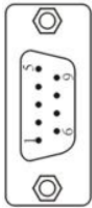

Figure 4 COM Ports and RS232/485 DIP switch

■ COM1 and COM2 are the standard DB9 male terminal, the definitions are as follows:

DB9 Male Terminal	Pin No.	Signal	
		RS232	RS485
	1	N.C.	B
	2	RXD	A
	3	TXD	N.C.
	4	DTR	N.C.
	5	GND	GND
	6	DSR	N.C.
	7	RTS	N.C.
	8	CTS	N.C.
	9	RI	N.C.

2.1.4.6 Power

There are two 2-pin power input terminals on the front. Both of them connect to the power DC input internally. It supports DC12V-24V input.

■ Pin definition of DC IN connector:

	Pin No.	Signal	Pin No.	Signal
	1	DC 12~24V	3	DC 12~24V
	2	GND	4	GND

PS: On the motherboard pin1 and pin3 are shorted, pin2 and pin4 are shorted and the maximum allowable current for a single terminal is 8A.

In order to make the machine can be used more reliably, it is recommended to add DC power filter in front of the controller when the field environment is not good, and ensure that the filter can be well grounded.

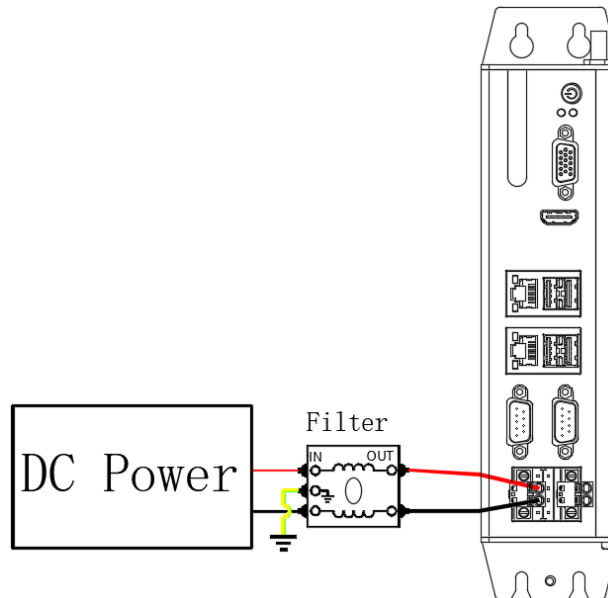

Figure 5 Power filter wiring diagram



1. Must check whether the voltage output of the power supply matches the PC DC input before connecting to the PC.
2. Must check the positive and negative pole marks on the housing before connecting to the power.
3. Must turn off the power before inserting or removing the boards or cables.
4. PE should be well grounded when operating.
5. Must do not connect AC power supply to the PC directly.

2.1.4.7 Remote switch

The side provides a remote on-off interface through which the machine can be powered on or off remotely.

	Pin No.	Signal
	1	GND
	2	Power_ON

2.2 NP-6135-H1

The NP-6135-H1 is a product combined by NP-6135 basic module and H1 add-on board, in addition of the functions supported by the NP-6135 basic module, four PoE ports, eight channels of digital inputs, eight channels of digital output and four channels of light control are extended in the H1 add-on board.

The product is widely used in vision control, robot control, motion control and other automation control fields.

2.2.1 Features

- ◆ 2 x Intel GbE LAN controller
- ◆ 4 x Intel GbE PoE LAN controller, Max 15W per channel
- ◆ 4 x USB 3.0, 1x USB 2.0 Type-A onboard for dongle
- ◆ 2 x RS232/485, RS485 supports automatic data flow control
- ◆ 8 x DI, 8 x DO
- ◆ 4 x PWM light control
- ◆ VGA and HDMI dual display ports
- ◆ 1 x miniPCIe slot can be extended to Wifi, 3G/4G
- ◆ Support Wall-mounted or DIN-Rail mounted
- ◆ -20 ~ 60°C wide temperature environment

2.2.2 Product Dimension

Unit: mm

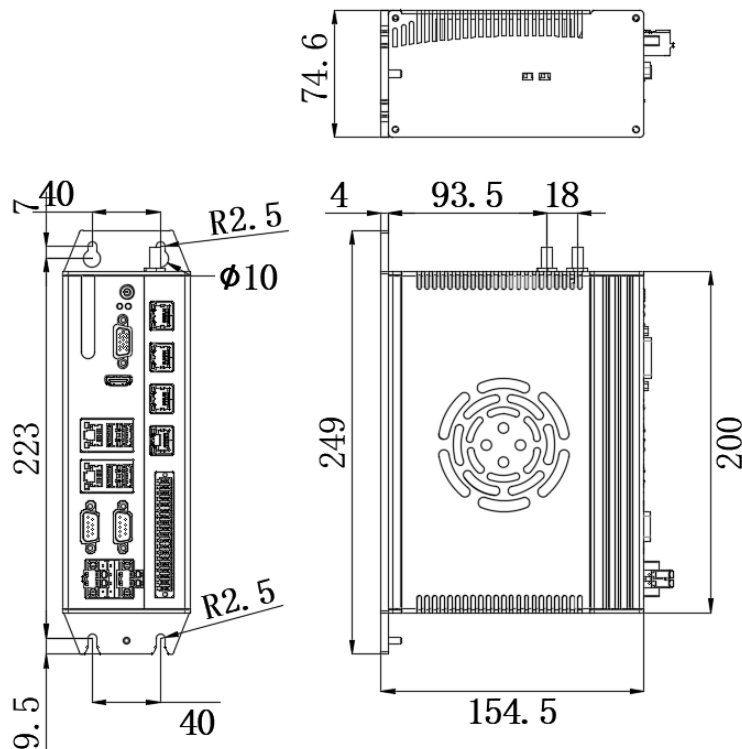
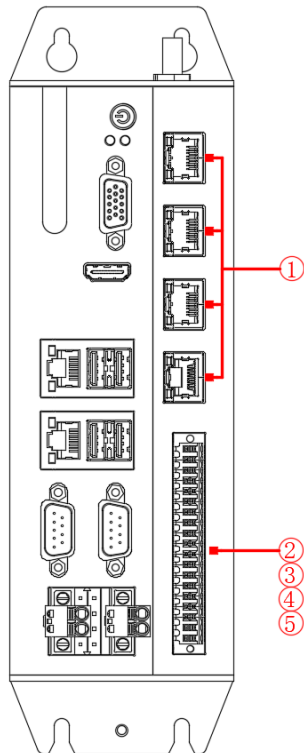

Figure 6 Dimension of NP-6135-H1

2.2.3 Product Specifications

Model Name		NP-6135-H1
System	CPU	Intel® Core™ 10th/11th gen i9/i7/i5/i3 LGA1200 type desktop CPU
	TDP	Max. 65W
	BIOS	AMI UEFI 64Mbit
	Memory	2 x SO-DIMM DDR4, max up to 32GB
	Storage	1 x mSATA bay
		1 x M.2(B Key, Type 2280) bay support SATA
	USB	4 x USB3.0, 1 x USB2.0 Type A on the board for USB dongle
	COM	2 x COM(DB-9), selectable to support RS232 or RS485 mode by the switch, RS485 support auto flow control, (ESD protection for RS232: Air gap ±8KV, Contact ±6KV)
	Ethernet	2 x Intel GbE LAN controller
	PoE	4 x Intel GbE PoE LAN controller, max. 15W per channel
	DI	8 x DI NPN/PNP, isolated 3750 Vrms
	DO	8 x DO, Transistor output, I _{max} :0.5A per channel, isolated 3750 Vrms
	Light Control	4 x PWM Light power control with external trigger input, I _{max} : 1A per channel
	VGA	Support up to 1920 x 1200 @ 60Hz
	HDMI	Support up to 3840 x 2160 @ 60Hz
	Expansions	1 x Full-size PCIe Mini slot with SIM card holder(with USB signal)
Watch Dog	1~255 levels programmable	
OS Support	Microsoft Windows	Windows 10
	Linux	Ubuntu, CentOS, Debian
Power	Voltage Input	DC12~24V ±10%, overcurrent, overvoltage and polarity inverse protection, (Must be DC24V when using Light Control)
	Power Consumption	Max. 300W
Chassis	Structure	Aluminum-magnesium alloy BOX with fan embedded to assist cooling, Wall-mounted or DIN-Rail fixing style.
	Dimensions	(L)200mm x (W)154.5mm x (H)74.6mm
	Net Weight	2.4Kg
Environment	Work Temperature	-20°C ~ 60°C (-4°F~140°F) with air flow (SSD)
	Storage Temperature	-40°C ~ 80°C (-40°F ~ 176°F) with air flow (SSD)
	Relative Humidity	5~95% (Non-condensing)
	Operating Vibration	5~500Hz, 1.5Grms@with SSD, Follow IEC60068-2-64
	Operating Shock	20G peak acceleration(11ms duration) with SSD, Follow IEC60068-2-27
	EMC	CE/FCC Class A

2.2.4 Description of Interfaces



No.	Definition
1	PoE LAN
2	DI
3	DO
4	PWM Light control output
5	PWM Light control trigger Input

Figure 7 Interfaces of NP-6135-H1

2.2.4.1 PoE LAN

There are four PoE Gigabit Ethernet ports: LAN3, LAN4, LAN5, and LAN6. The maximum power of each channel is 15W.

Pin definition of PoE LAN connector:

Pin No.	Signal	
	100BASE-TX	1000BASE-T
1	TX+	TRD+(0)
2	TX-	TRD-(0)
3	RX+	TRD+(1)
4	N.C.	TRD+(2)
5	N.C.	TRD-(2)
6	RX-	TRD-(1)
7	N.C.	TRD+(3)
8	N.C.	TRD-(3)

There are two status leds in the RJ45 connector indicate the status of the link and transmit separately. Link led is on when link successfully, and when the network is working in the 1000Mbps, the transmit led is blinking in orange color and in green color when working in the other speed.

Type	Parameters
Network Type	1000BASE-T/100BASE-TX/10BASE-T
Transmission Speed*	1000M/100M/10Mbps
Maximum Cable Distance	100m/segment
NIC Type	Intel® Ethernet Controller

*When the transmission speed is 1000Mbps, a network cable of at least CAT 5e is required.



1. PoE LAN cable 1-2 are positive, 3-6 are negative and cannot be shorted;
2. No crossover PoE LAN cable allowed;
3. CAT-6 or higher PoE LAN cable recommended.

2.2.4.2 DIO

The H1 add-on board provides 8 channels of isolated DI, 8 channels of isolated DO, 4 channels of light PWM control outputs(Support external hard trigger input).

■ Pin definition of the DIO connector:

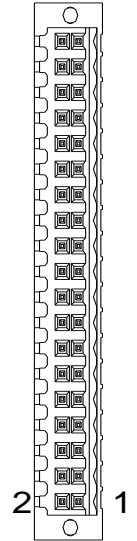
	Pin No.	Signal	Description	Pin No.	Signal	Description
		38	DI0	Digital input channel 0	37	DO0
36		DI1	Digital input channel 1	35	DO1	Digital output channel 1
34		DI2	Digital input channel 2	33	DO2	Digital output channel 2
32		DI3	Digital input channel 3	31	DO3	Digital output channel 3
30		DI4	Digital input channel 4	29	DO4	Digital output channel 4
28		DI5	Digital input channel 5	27	DO5	Digital output channel 5
26		DI6	Digital input channel 6	25	DO6	Digital output channel 6
24		DI7	Digital input channel 7	23	DO7	Digital output channel 7
22		①V+	Power output positive	21	DGND	DO GND
20		Com1	Common end of digital input channel	19	DGND	DO GND
18		①V-	Power output negative	17	L24V	Reserved
16		CH1+	Light control channel 1 output positive	15	L0V	Reserved
14		CH1-	Light control channel 1 output negative	13	FS	Reserved
12		CH2+	Light control channel 2 output positive	11	②GND	GND
10		CH2-	Light control channel 2 output negative	9	LCom	Common end of Light control trigger input
8		CH3+	Light control channel 3 output positive	7	TR1	Light control channel 1 trigger input
6		CH3-	Light control channel 3 output negative	5	TR2	Light control channel 2 trigger input
4		CH4+	Light control channel 4 output positive	3	TR3	Light control channel 3 trigger input
2		CH4-	Light control channel 4 output negative	1	TR4	Light control channel 4 trigger input

Note: ①. V+ and V-are internally isolated power supply outputs, 24V, max. current 40mA, only for Input signal by dry contact power supply;

②. GND is the common ground terminal where the light controller input signal is a dry contact, not available for wet contact.

2.2.4.2.1 DI

The H1 add-on board provides 8 isolated digital inputs (isolation voltage 3750Vrms), the maximum allowable voltage cannot be exceeded DC30V. Because of the internal circuit adopts bidirectional optocoupler isolation, it is compatible with PNP and NPN wiring solution. The reference wiring diagrams are as follows:

- NPN connection in wet contact way:

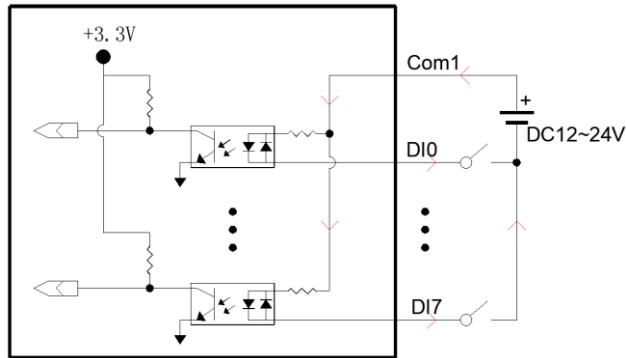

Figure 8 DI NPN wiring solution

- PNP connection in wet contact way:

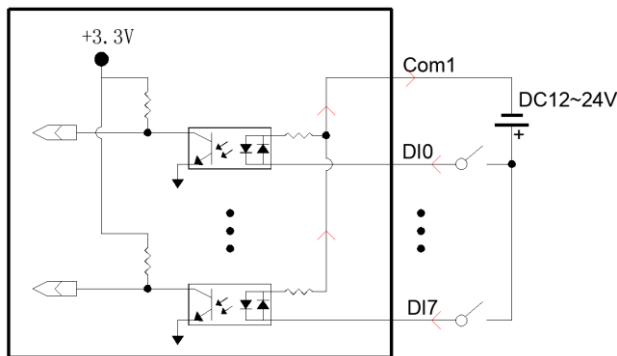

Figure 9 DI PNP wiring solution

- NPN connection in dry contact way:

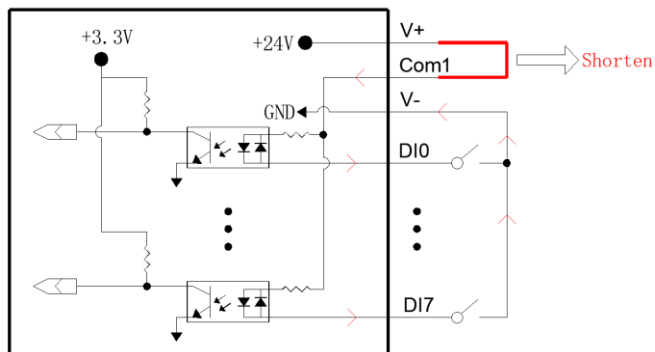

Figure 10 DI NPN wiring solution

- PNP connection in dry contact way:

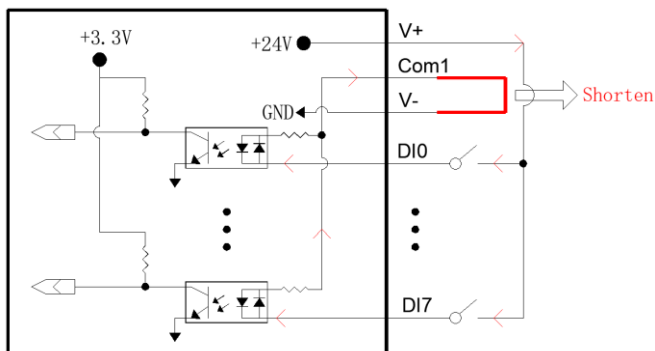

Figure 11 DI PNP wiring solution

2.2.4.2.2 DO

The H1 add-on board provides 8 Digital Output channels, transistor output, I_{max} : 500mA, V_{max} : 50V. Please remind that a diode should be connected in parallel for freewheeling when external inductive load is connected.

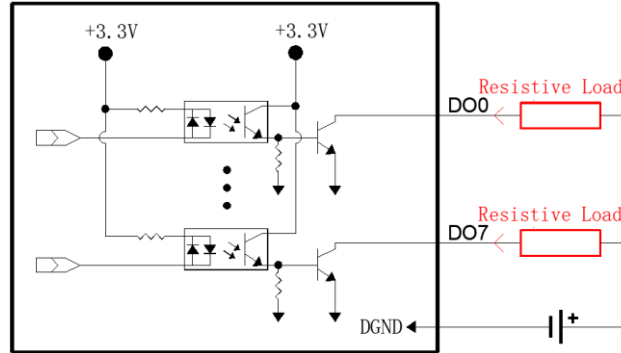

Figure 12 Wiring of resistive load

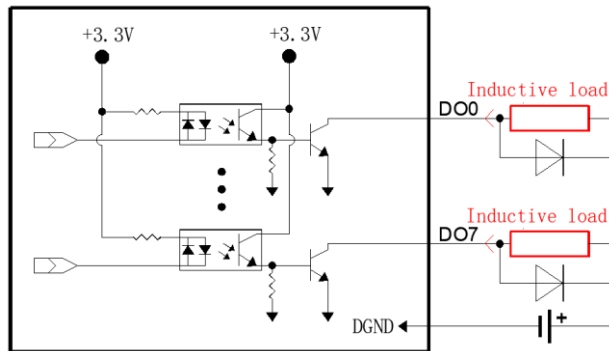

Figure 13 Wiring of inductive load



1. DO output current <500mA;
2. DO load voltage <50VDC;
3. Positive and negative power supply terminals cannot be connected to the DO signal terminal and DOGND directly.

2.2.4.2.3 PWM Light Control

The H1 add-on board provides 4 channels of PWM light control, the maximum output current for per channel is 1A, and the dimming level is 100. Kindly pay attention to the PC power supply input must be DC24V when using light control function. Each channel has its own external hard trigger input. The reference wiring solutions are as follows:

1. PWM light control output :

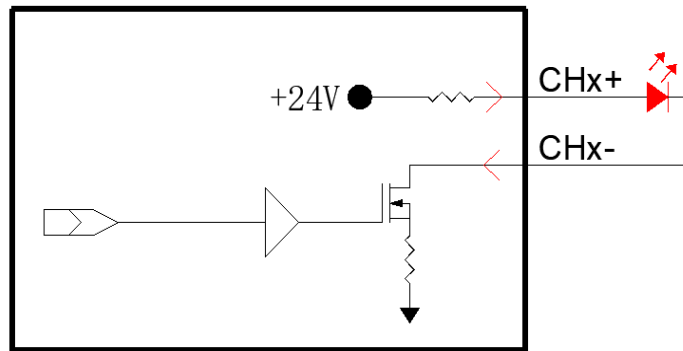

Figure 14 Wiring of Light control output



1. Must be use DC24V power supply when use PWN light control function;
2. The power supply cannot be less than the total power consumption of the full load and the light;
3. The positive and negative PWM output cannot be shorted.

2. Light control external trigger
 - NPN connection in wet contact way

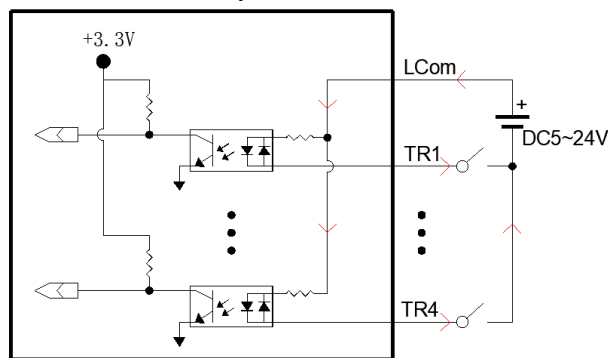

Figure 15 NPN wiring solution

- PNP connection in wet contact way:

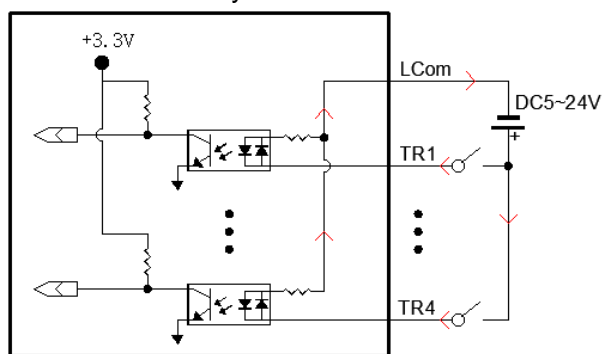

Figure 16 PNP wiring solution

- NPN connection in dry contact way:

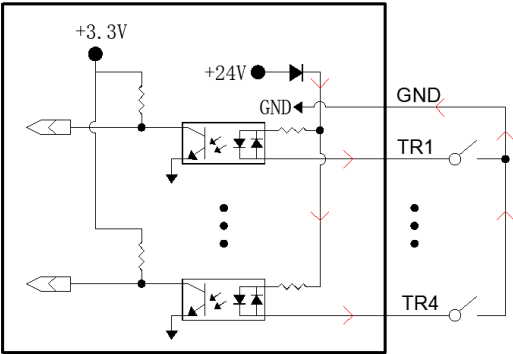

Figure 17 NPN wiring solution



When using an external hard trigger signal for light control, the light controller needs to be set to hard trigger or hard switch mode in the software.

2.3 NP-6135-JH2

The NP-6135-JH2 is a product combined by NP-6135 basic module and JH2 add-on board, in addition of the functions supported by the NP-6135 basic module, two PoE ports, eight channels of digital inputs, eight channels of digital output and four channels of light control are extended in the JH2 add-on board.

The product is widely used in vision control, robot control, motion control and other automation control fields.

2.3.1 Features

- ◆ 2 x Intel GbE LAN controller
- ◆ 2 x Intel GbE PoE LAN controller, Max 15W
- ◆ 4 x USB 3.0, 1x USB 2.0 Type-A onboard for dongle
- ◆ 2 x RS232/485, RS485 supports automatic data flow control
- ◆ 8 x DI, 8 x DO
- ◆ 4 x PWM light source control
- ◆ VGA and HDMI dual display ports
- ◆ 1 x miniPCIe slot can be extended to Wifi, 3G/4G
- ◆ Support Wall-mounted or DIN-Rail mounted
- ◆ -20 ~ 60°C wide temperature environment

2.3.2 Product Dimension

Unit: mm

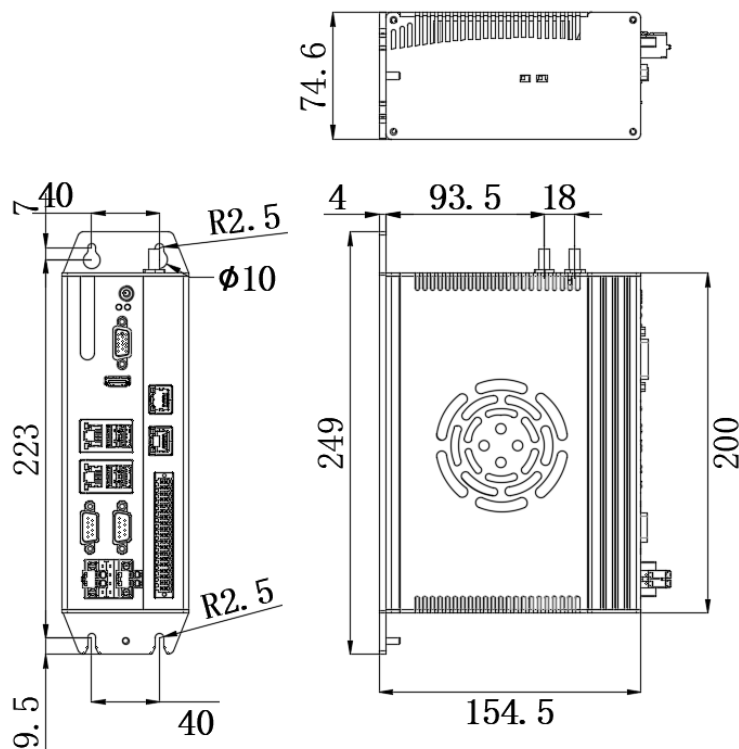
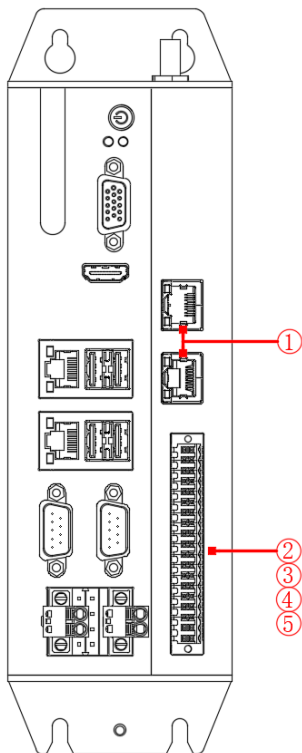

Figure 18 Dimension of NP-6135-JH2

2.3.3 Product Specifications

Model Name		NP-6135-JH2
System	CPU	Intel® Core™ 10th/11th gen i9/i7/i5/i3 LGA1200 type desktop CPU
	TDP	Max. 65W
	BIOS	AMI UEFI 64Mbit
	Memory	2 x SO-DIMM DDR4, max up to 32GB
	Storage	1 x mSATA bay
		1 x M.2(B Key, Type 2280) bay support SATA
	USB	4 x USB3.0, 1 x USB2.0 Type A on the board for USB dongle
	COM	2 x COM(DB-9), selectable to support RS232 or RS485 mode by the switch, RS485 support auto flow control, (ESD protection for RS232: Air gap ±8KV, Contact ±6KV)
	Ethernet	2 x Intel GbE LAN controller
	PoE	2 x Intel GbE PoE LAN controller, max. 15W per channel
	DI	8 x DI NPN/PNP, isolated 3750 Vrms
	DO	8 x DO, Transistor output, I _{max} :0.5A per channel, isolated 3750 Vrms
	Light Control	4 x PWM Light power control with external trigger input, I _{max} : 1A per channel
	VGA	Support up to 1920 x 1200 @ 60Hz
	HDMI	Support up to 3840 x 2160 @ 60Hz
	Expansions	1 x Full-size PCIe Mini slot with SIM card holder(with USB signal)
Watch Dog	1~255 levels programmable	
OS Support	Microsoft Windows	Windows 10
	Linux	Ubuntu, CentOS, Debian
Power	Voltage Input	DC12~24V ±10%, overcurrent, overvoltage and polarity inverse protection, (Must be DC24V when using Light Control)
	Power Consumption	Max. 220W
Chassis	Structure	Aluminum-magnesium alloy BOX with fan embedded to assist cooling, Wall-mounted or DIN-Rail fixing style.
	Dimensions	(L)200mm x (W)154.5mm x (H)74.6mm
	Net Weight	2.4Kg
Environment	Work Temperature	-20°C ~ 60°C (-4°F~140°F) with air flow (SSD)
	Storage Temperature	-40°C ~ 80°C (-40°F ~ 176°F) with air flow (SSD)
	Relative Humidity	5~95% (Non-condensing)
	Operating Vibration	5~500Hz, 1.5Grms@with SSD, Follow IEC60068-2-64
	Operating Shock	20G peak acceleration(11ms duration) with SSD, Follow IEC60068-2-27
	EMC	CE/FCC Class A

2.3.4 Description of Interfaces



No.	Definition
1	PoE LAN
2	DI
3	DO
4	PWM Light source control output
5	PWM Light source control triggerInput

Figure 19 Interfaces of NP-6135-JH2

2.3.4.1 PoE LAN

There are two PoE Gigabit Ethernet ports: LAN3, LAN4. The maximum power of each channel is 15W.

■ Pin definition of PoE LAN connector:

Pin No.	Signal	
	100BASE-TX	1000BASE-T
1	TX+	TRD+(0)
2	TX-	TRD-(0)
3	RX+	TRD+(1)
4	N.C.	TRD+(2)
5	N.C.	TRD-(2)
6	RX-	TRD-(1)
7	N.C.	TRD+(3)
8	N.C.	TRD-(3)

There are two status leds in the RJ45 connector indicate the status of the link and transmit separately. Link led is on when link successfully, and when the network is working in the 1000Mbps, the transmit led is blinking in orange color and in green color when working in the other speed.

Type	Parameters
Network Type	1000BASE-T/100BASE-TX/10BASE-T
Transmission Speed*	1000M/100M/10Mbps
Maximum Cable Distance	100m/segment
NIC Type	Intel® Ethernet Controller

*When the transmission speed is 1000Mbps, a network cable of at least CAT 5e is required.



1. PoE LAN cable 1-2 are positive, 3-6 are negative and cannot be shorted;
2. No crossover PoE LAN cable allowed;
3. CAT-6 or higher PoE LAN cable recommended.

2.3.4.2 DIO

The JH2 add-on board provides 8 channels of isolated DI, 8 channels of isolated DO, 4 channels of light PWM control outputs(Support external hard trigger input).

■ Pin definition of the DIO connector:

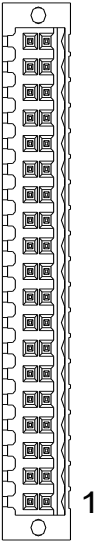
	Pin No.	Signal	Description	Pin No.	Signal	Description
		38	DI0	Digital input channel 0	37	DO0
36		DI1	Digital input channel 1	35	DO1	Digital output channel 1
34		DI2	Digital input channel 2	33	DO2	Digital output channel 2
32		DI3	Digital input channel 3	31	DO3	Digital output channel 3
30		DI4	Digital input channel 4	29	DO4	Digital output channel 4
28		DI5	Digital input channel 5	27	DO5	Digital output channel 5
26		DI6	Digital input channel 6	25	DO6	Digital output channel 6
24		DI7	Digital input channel 7	23	DO7	Digital output channel 7
22		①V+	Power output positive	21	DGND	DO GND
20		Com1	Common end of digital input channel	19	DGND	DO GND
18		①V-	Power output negative	17	L24V	Reserved
16		CH1+	Light control channel 1 output positive	15	L0V	Reserved
14		CH1-	Light control channel 1 output negative	13	FS	Reserved
12		CH2+	Light control channel 2 output positive	11	②GND	GND
10		CH2-	Light control channel 2 output negative	9	LCom	Common end of Light control trigger input
8		CH3+	Light control channel 3 output positive	7	TR1	Light control channel 1 trigger input
6	CH3-	Light control channel 3 output negative	5	TR2	Light control channel 2 trigger input	
4	CH4+	Light control channel 4 output positive	3	TR3	Light control channel 3 trigger input	
2	CH4-	Light control channel 4 output negative	1	TR4	Light control channel 4 trigger input	

NOTE:①. V+ and V-are internally isolated power supply outputs, 24V, max. current 40mA, only for Input signal by dry contact power supply;

②. GND is the common ground terminal where the light controller input signal is a dry contact, not available for wet contact.

2.3.4.2.4 DI

The JH2 add-on board provides 8 isolated digital inputs (isolation voltage 3750Vrms), the maximum allowable voltage cannot be exceeded DC30V. Because of the internal circuit adopts bidirectional optocoupler isolation, it is compatible with PNP and NPN wiring solution. The reference wiring diagrams are as follows:

- NPN connection in wet contact way:

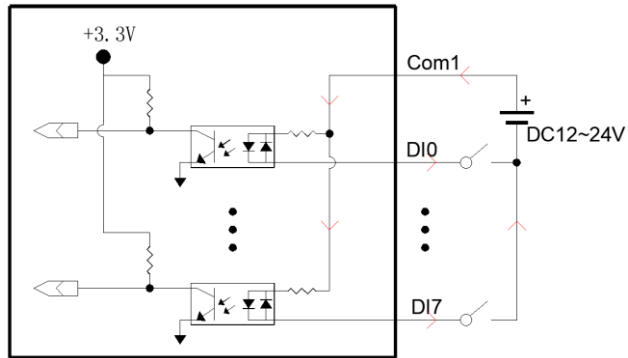

Figure 20 DI NPN wiring solution

- PNP connection in wet contact way:

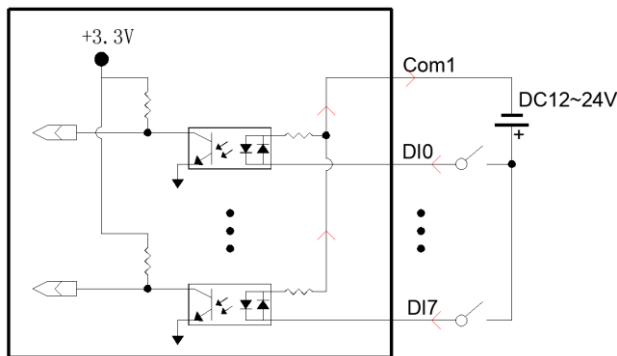

Figure 21 DI PNP wiring solution

- NPN connection in dry contact way:

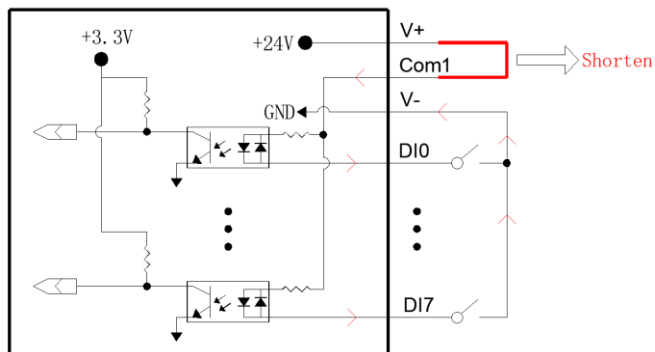

Figure 22 DI NPN wiring solution

- PNP connection in dry contact way:

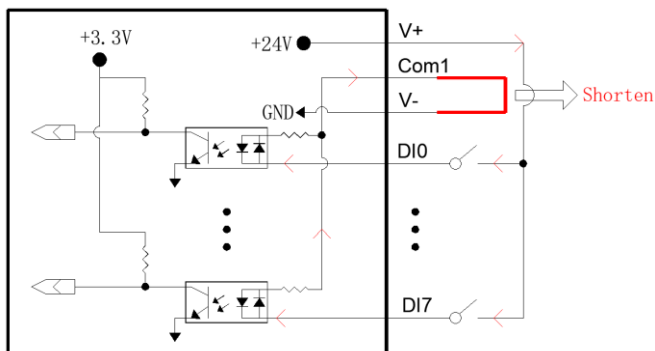

Figure 23 DI PNP wiring solution

2.3.4.2.5 DO

The JH2 add-on board provides 8 Digital Output channels, transistor output, I_{max} : 500mA, V_{max} : 50V. Please remind that a diode should be connected in parallel for freewheeling when external inductive load is connected.

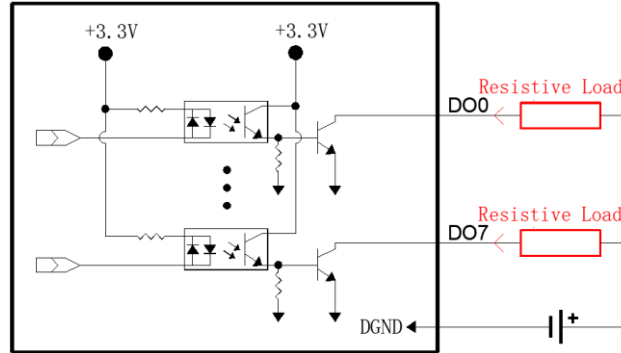

Figure 24 Wiring of resistive load

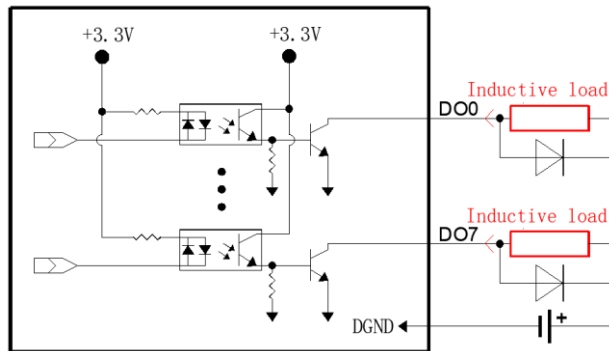

Figure 25 Wiring of inductive load



1. DO output current <500mA;
2. DO load voltage <50VDC;
3. Positive and negative power supply terminals cannot connected to the DO signal terminal and DOGND directly.

2.3.4.2.6 PWM Light Control

The JH2 add-on board provides 4 channels of PWM light control, the maximum output current for per channel is 1A, and the dimming level is 100. Kindly pay attention to the PC power supply input must be DC24V when using light control function. Each channel has its own external hard trigger input. The reference wiring solutions are as follows:

1. PWM light control output :

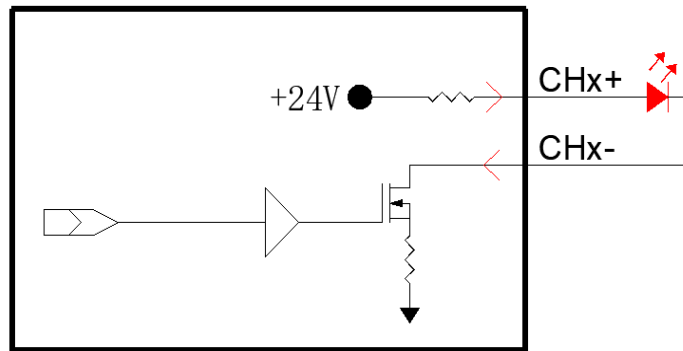

Figure 26 Wiring of Light source



1. Must be use DC24V power supply when use PWM light control function;
2. The power supply cannot be less than the total power consumption of the full load and the light source;
3. The positive and negative PWM outputs cannot be shorted.

2. Light source external trigger
 - NPN connection in wet contact way

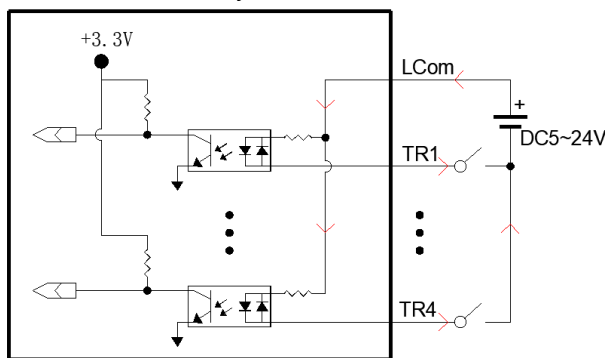

Figure 27 NPN wiring solution

- PNP connection in wet contact way:

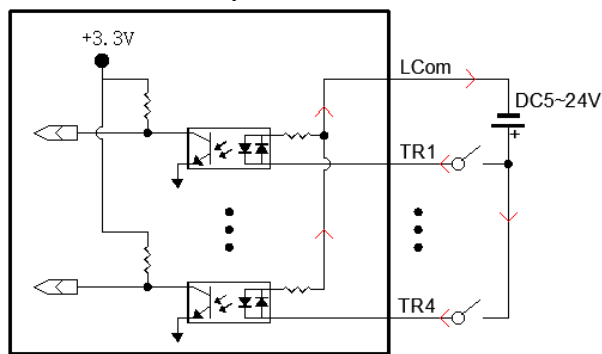

Figure 28 PNP wiring solution

- NPN connection in dry contact way:

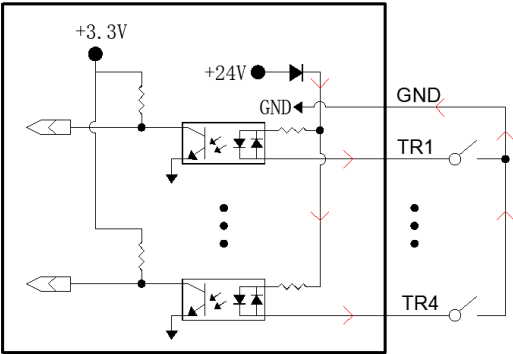

Figure 29 NPN wiring solution



When using an external hard trigger signal for light control, the light controller needs to be set to hard trigger or hard switch mode in the software.

2.4 NP-6135-H1B

The NP-6135-H1B is a product combined by NP-6135 basic module and H1B add-on board, in addition of the functions supported by the NP-6135 basic module, four PoE ports, 16 channels of digital inputs, 16 channels of digital output are extended in the H1B add-on board.

The product is widely used in vision control, robot control, motion control and other automation control fields.

2.4.1 Features

- ◆ 2 x Intel GbE LAN controller
- ◆ 4 x Intel GbE PoE LAN controller, Max 15W
- ◆ 4 x USB 3.0, 1x USB 2.0 Type-A onboard for dongle
- ◆ 2 x RS232/485, RS485 supports automatic data flow control
- ◆ 16 x DI, 16 x DO
- ◆ VGA and HDMI dual display ports
- ◆ 1 x miniPCIe slot can be extended to Wifi, 3G/4G
- ◆ Support Wall-mounted or DIN-Rail mounted
- ◆ -20 ~ 60°C wide temperature environment

2.4.2 Product Dimension

Unit: mm

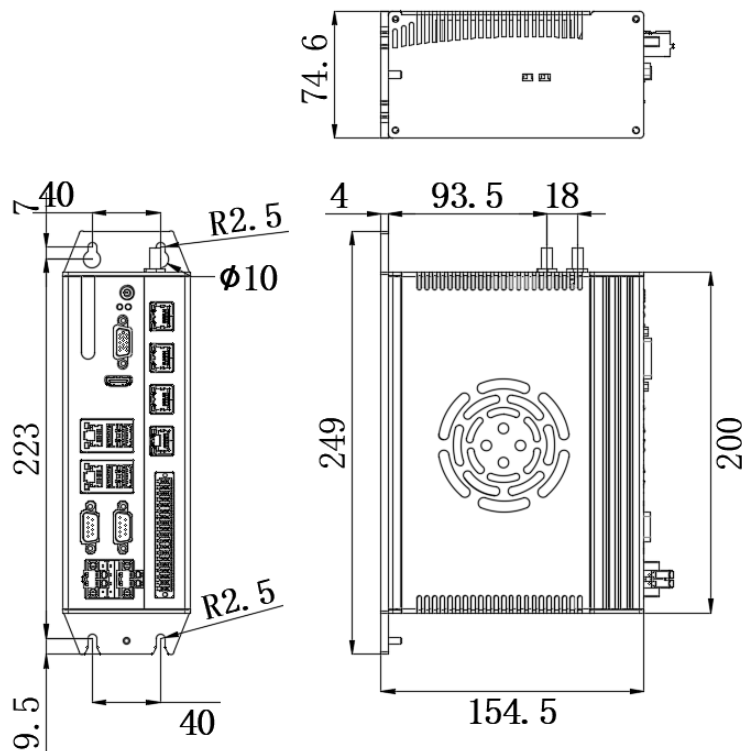
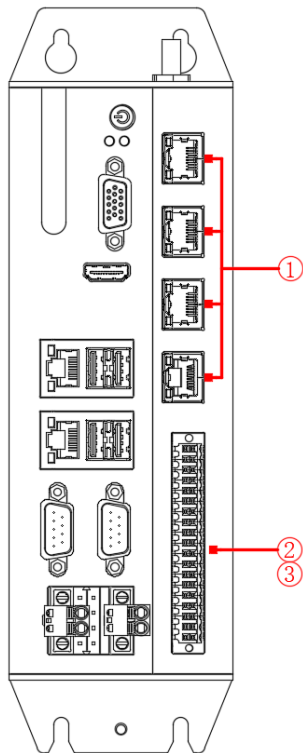

Figure 30 Dimension of NP-6135-H1B

2.4.3 Product Specifications

Model Name		NP-6135-H1B	
System	CPU	Intel® Core™ 10th/11th gen i9/i7/i5/i3 LGA1200 type CPU	
	TDP	Max. 65W	
	BIOS	AMI UEFI 64Mbit	
	Memory	2 x SO-DIMM DDR4, max up to 32GB	
	Storage		1 x mSATA bay
			1 x M.2(B Key, Type 2280) bay support SATA
	USB	4 x USB3.0, 1 x USB2.0 Type A on the board for USB dongle	
	COM	2 x COM(DB-9), selectable to support RS232 or RS485 mode by the switch, RS485 support auto flow control, (ESD protection for RS232: Air gap ±8KV, Contact ±6KV)	
	Ethernet	2 x Intel GbE LAN controller	
	PoE	4 x Intel GbE PoE LAN controller, max. 15W per channel	
	DI	16 x DI NPN/PNP, isolated 3750 Vrms	
	DO	16 x DO, Transistor output, I _{max} :0.5A per channel, isolated 3750 Vrms	
	VGA	Support up to 1920 x 1200 @ 60Hz	
	HDMI	Support up to 3840 x 2160 @ 60Hz	
	Expansions	1 x Full-size PCIe Mini slot with SIM card holder(with USB signal)	
Watch Dog	1~255 levels programmable		
OS Support	Microsoft Windows	Windows 10	
	Linux	Ubuntu, CentOS, Debian	
Power	Voltage Input	DC12~24V ±10%, overcurrent, overvoltage and polarity inverse protection	
	Power Consumption	Max. 180W	
Chassis	Structure	Aluminum-magnesium alloy BOX with fan embedded to assist cooling, Wall-mounted or DIN-Rail fixing style.	
	Dimensions	(L)200mm x (W)154.5mm x (H)74.6mm	
	Net Weight	2.4Kg	
Environment	Work Temperature	-20°C ~ 60°C (-4°F~140°F) with air flow (SSD)	
	Storage Temperature	-40°C ~ 80°C (-40°F ~ 176°F) with air flow (SSD)	
	Relative Humidity	5~95% (Non-condensing)	
	Operating Vibration	5~500Hz, 1.5Grms@with SSD, Follow IEC60068-2-64	
	Operating Shock	20G peak acceleration(11ms duration) with SSD, Follow IEC60068-2-27	
EMC	CE/FCC Class A		

2.4.4 Description of Interfaces



No.	Definition
1	PoE LAN
2	DI
3	DO

Figure 31 Interfaces of NP-6135-H1B

2.4.4.1 PoE LAN

There are four PoE Gigabit Ethernet ports: LAN3, LAN4, LAN5, and LAN6. The maximum power of each channel is 15W.

■ Pin definition of PoE LAN connector:

Pin No.	Signal	
	100BASE-TX	1000BASE-T
1	TX+	TRD+(0)
2	TX-	TRD-(0)
3	RX+	TRD+(1)
4	N.C.	TRD+(2)
5	N.C.	TRD-(2)
6	RX-	TRD-(1)
7	N.C.	TRD+(3)
8	N.C.	TRD-(3)

There are two status leds in the RJ45 connector indicate the status of the link and transmit separately. Link led is on when link successfully, and when the network is working in the 1000Mbps, the transmit led is blinking in orange color and in green color when working in the other speed.

Type	Parameters
Network Type	1000BASE-T/100BASE-TX/10BASE-T
Transmission Speed*	1000M/100M/10Mbps
Maximum Cable Distance	100m/segment
NIC Type	Intel® Ethernet Controller

*When the transmission speed is 1000Mbps, a network cable of at least CAT 5e is required.



1. PoE LAN cable 1-2 are positive, 3-6 are negative and cannot be shorted;
2. No crossover PoE LAN cable allowed;
3. CAT-6 or higher PoE LAN cable recommended.

2.4.4.2 DIO

The H1B add-on board provides 16 channels of isolated DI, 16 channels of isolated DO.

■ Pin definition of DIO connector:

Pin No.	Signal	Description	Pin No.	Signal	Description
38	DICOM	Digital input common	37	DICOM	Digital input common
36	DIGND	Reserved	35	DIGND	Reserved
34	DI0	Digital input channel 0	33	DI8	Digital input channel 8
32	DI1	Digital input channel 1	31	DI9	Digital input channel 9
30	DI2	Digital input channel 2	29	DI10	Digital input channel 10
28	DI3	Digital input channel 3	27	DI11	Digital input channel 11
26	DI4	Digital input channel 4	25	DI12	Digital input channel 12
24	DI5	Digital input channel 5	23	DI13	Digital input channel 13
22	DI6	Digital input channel 6	21	DI14	Digital input channel 14
20	DI7	Digital input channel 7	19	DI15	Digital input channel 15
18	DO0	Digital output channel 0	17	DO8	Digital output channel 8
16	DO1	Digital output channel 1	15	DO9	Digital output channel 9
14	DO2	Digital output channel 2	13	DO10	Digital output channel 10
12	DO3	Digital output channel 3	11	DO11	Digital output channel 11
10	DO4	Digital output channel 4	9	DO12	Digital output channel 12
8	DO5	Digital output channel 5	7	DO13	Digital output channel 13
6	DO6	Digital output channel 6	5	DO14	Digital output channel 14
4	DO7	Digital output channel 7	3	DO15	Digital output channel 15
2	DOGND	Digital output ground common	1	DOGND	Digital output ground common

2.4.4.2.1 DI

The H1B add-on board provides 16 channels of isolated digital inputs (isolation voltage 3750Vrms), the maximum allowable voltage cannot be exceeded DC30V. Because of the internal circuit adopts bidirectional optocoupler isolation, it is compatible with PNP and NPN wiring solution. The reference wiring diagrams are as follows:

➤ NPN connection in wet contact way:

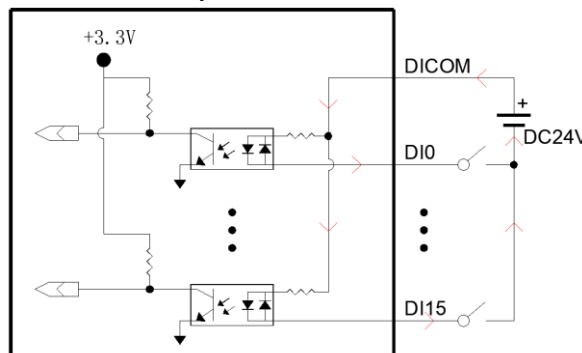

Figure 32 DI NPN wiring solution

➤ PNP connection in wet contact way:

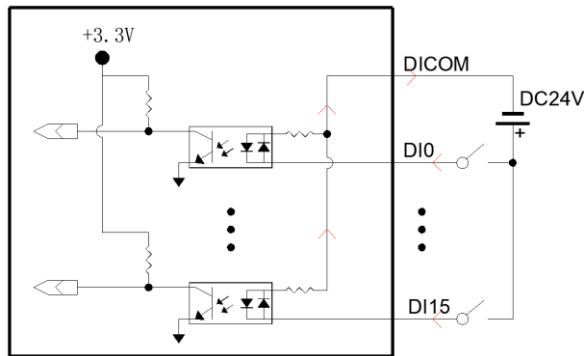

Figure 33 DI PNP wiring solution

2. 4. 4. 2. 2 DO

The H1B add-on board provides 8 channels of Digital Output channels, transistor output, I_{max} : 500mA, V_{max} : 50V. Please remind that a diode should be connected in parallel for freewheeling when external inductive load is connected.

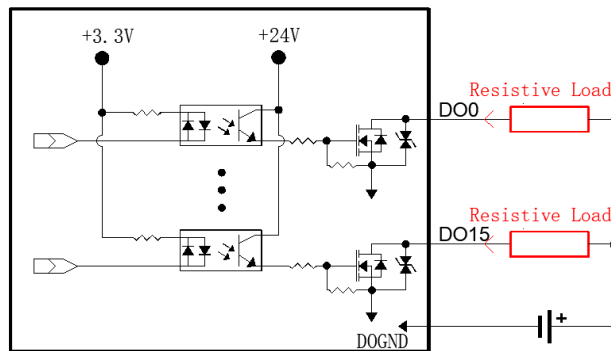

Figure 34 Wiring of resistive load

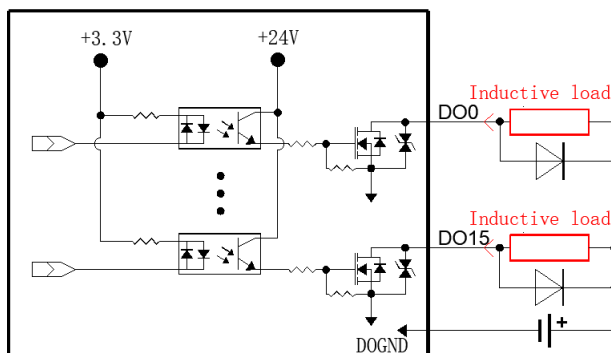

Figure 35 Wiring of inductive load



1. DO output current <math>< 500\text{mA}</math>;
2. DO load voltage <math>< 50\text{VDC}</math>;
3. Positive and negative power supply terminals can not connected to the DO signal terminal and DOGND directly.

2.5 NP-6135-JH2B

The NP-6135-JH2B is a product combined by NP-6135 basic module and JH2B add-on board, in addition of the functions supported by the NP-6135 basic module, two PoE ports, 16 channels of digital inputs, 16 channels of digital output are extended in the JH2B add-on board.

The product is widely used in vision control, robot control, motion control and other automation control fields.

2.5.1 Features

- ◆ 2 x Intel GbE LAN controller
- ◆ 2 x Intel GbE PoE LAN controller, Max 15W
- ◆ 4 x USB 3.0, 1x USB 2.0 Type-A onboard for dongle
- ◆ 2 x RS232/485, RS485 supports automatic data flow control
- ◆ 16 x DI, 16 x DO
- ◆ VGA and HDMI dual display ports
- ◆ 1 x miniPCIe slot can be extended to Wifi, 3G/4G
- ◆ Support Wall-mounted or DIN-Rail mounted
- ◆ -20 ~ 60°C wide temperature environment

2.5.2 Product Dimension

Unit: mm

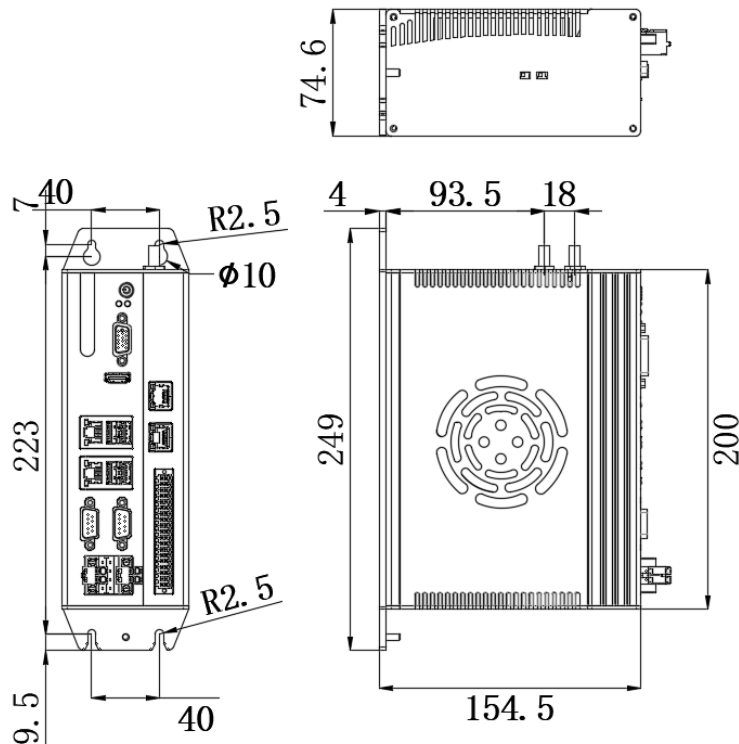
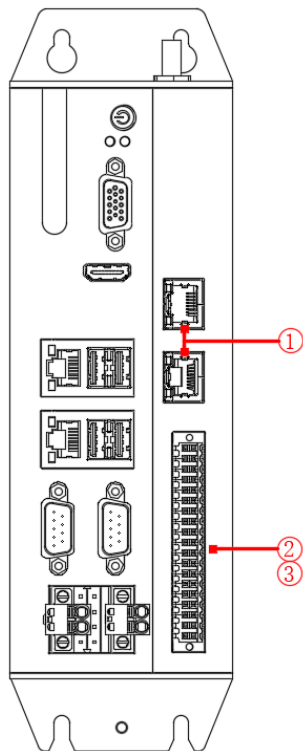

Figure 36 Dimension of NP-6135-JH2B

2.5.3 Product Specifications

Model Name		NP-6135-JH2B	
System	CPU	Intel® Core™ 10th/11th gen i9/i7/i5/i3 LGA1200 type desktop CPU	
	TDP	Max. 65W	
	BIOS	AMI UEFI 64Mbit	
	Memory	2 x SO-DIMM DDR4, max up to 32GB	
	Storage		1 x mSATA bay
			1 x M.2(B Key, Type 2280) bay support SATA
	USB	4 x USB3.0, 1 x USB2.0 Type A on the board for USB dongle	
	COM	2 x COM(DB-9), selectable to support RS232 or RS485 mode by the switch, RS485 support auto flow control, (ESD protection for RS232: Air gap ±8KV, Contact ±6KV)	
	Ethernet	2 x Intel GbE LAN controller	
	PoE	2 x Intel GbE PoE LAN controller, max. 15W per channel	
	DI	16 x DI NPN/PNP, isolated 3750 Vrms	
	DO	16 x DO, Transistor output, I _{max} :0.5A per channel, isolated 3750 Vrms	
	VGA	Support up to 1920 x 1200 @ 60Hz	
	HDMI	Support up to 3840 x 2160 @ 60Hz	
	Expansions	1 x Full-size PCIe Mini slot with SIM card holder(with USB signal)	
Watch Dog	1~255 levels programmable		
OS Support	Microsoft Windows	Windows 10	
	Linux	Ubuntu, CentOS, Debian	
Power	Voltage Input	DC12~24V ±10%, overcurrent, overvoltage and polarity inverse protection	
	Power Consumption	Max. 150W	
Chassis	Structure	Aluminum-magnesium alloy BOX with fan embedded to assist cooling, Wall-mounted or DIN-Rail fixing style.	
	Dimensions	(L)200mm x (W)154.5mm x (H)74.6mm	
	Net Weight	2.4Kg	
Environment	Work Temperature	-20°C ~ 60°C (-4°F~140°F) with air flow (SSD)	
	Storage Temperature	-40°C ~ 80°C (-40°F ~ 176°F) with air flow (SSD)	
	Relative Humidity	5~95% (Non-condensing)	
	Operating Vibration	5~500Hz, 1.5Grms@with SSD, Follow IEC60068-2-64	
	Operating Shock	20G peak acceleration(11ms duration) with SSD, Follow IEC60068-2-27	
	EMC	CE/FCC Class A	

2.5.4 Description of Interfaces



No.	Definition
1	PoE LAN
2	DI
3	DO

Figure 37 Interfaces of NP-6135-H1B

2.5.4.1 PoE LAN

There are two PoE Gigabit Ethernet ports: LAN3, LAN4. The maximum power of each channel is 15W.

■ Pin definition of PoE LAN connector:

Pin No.	Signal	
	100BASE-TX	1000BASE-T
1	TX+	TRD+(0)
2	TX-	TRD-(0)
3	RX+	TRD+(1)
4	N.C.	TRD+(2)
5	N.C.	TRD-(2)
6	RX-	TRD-(1)
7	N.C.	TRD+(3)
8	N.C.	TRD-(3)

There are two status leds in the RJ45 connector indicate the status of the link and transmit separately. Link led is on when link successfully, and when the network is working in the 1000Mbps, the transmit led is blinking in orange color and in green color when working in the other speed.

Type	Parameters
Network Type	1000BASE-T/100BASE-TX/10BASE-T
Transmission Speed*	1000M/100M/10Mbps
Maximum Cable Distance	100m/segment
NIC Type	Intel® Ethernet Controller

*When the transmission speed is 1000Mbps, a network cable of at least CAT 5e is required.



1. PoE LAN cable 1-2 are positive, 3-6 are negative and cannot be shorted;
2. No crossover PoE LAN cable allowed;
3. CAT-6 or higher PoE LAN cable recommended.

2.5.4.2 DIO

The JH2B add-on board provides 16 channels of isolated DI, 16 channels of isolated DO.

■ Pin definition of DIO connector:

Pin No.	Signal	Description	Pin No.	Signal	Description
38	DICOM	Digital input common	37	DICOM	Digital input common
36	DIGND	Reserved	35	DIGND	Reserved
34	DI0	Digital input channel 0	33	DI8	Digital input channel 8
32	DI1	Digital input channel 1	31	DI9	Digital input channel 9
30	DI2	Digital input channel 2	29	DI10	Digital input channel 10
28	DI3	Digital input channel 3	27	DI11	Digital input channel 11
26	DI4	Digital input channel 4	25	DI12	Digital input channel 12
24	DI5	Digital input channel 5	23	DI13	Digital input channel 13
22	DI6	Digital input channel 6	21	DI14	Digital input channel 14
20	DI7	Digital input channel 7	19	DI15	Digital input channel 15
18	DO0	Digital output channel 0	17	DO8	Digital output channel 8
16	DO1	Digital output channel 1	15	DO9	Digital output channel 9
14	DO2	Digital output channel 2	13	DO10	Digital output channel 10
12	DO3	Digital output channel 3	11	DO11	Digital output channel 11
10	DO4	Digital output channel 4	9	DO12	Digital output channel 12
8	DO5	Digital output channel 5	7	DO13	Digital output channel 13
6	DO6	Digital output channel 6	5	DO14	Digital output channel 14
4	DO7	Digital output channel 7	3	DO15	Digital output channel 15
2	DOGND	Digital output ground common	1	DOGND	Digital output ground common

2.5.4.2.1 DI

The JH2B add-on board provides 16 channels of isolated digital inputs (isolation voltage 3750Vrms), the maximum allowable voltage cannot be exceeded DC30V. Because of the internal circuit adopts bidirectional optocoupler isolation, it is compatible with PNP and NPN wiring solution. The reference wiring diagrams are as follows:

➤ NPN connection in wet contact way:

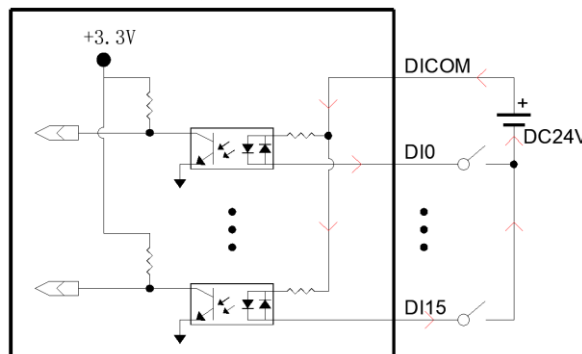

Figure 38 DI NPN wiring solution

➤ PNP connection in wet contact way:

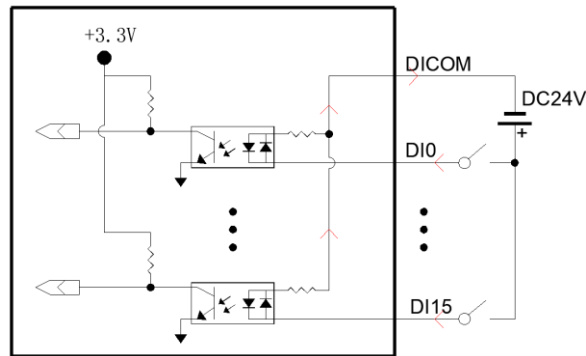

Figure 39 DI PNP wiring solution

2. 5. 4. 2. 2 DO

The JH2B add-on board provides 8 channels of Digital Output channels, transistor output, I_{max} : 500mA, V_{max} : 50V. Please remind that a diode should be connected in parallel for freewheeling when external inductive load is connected.

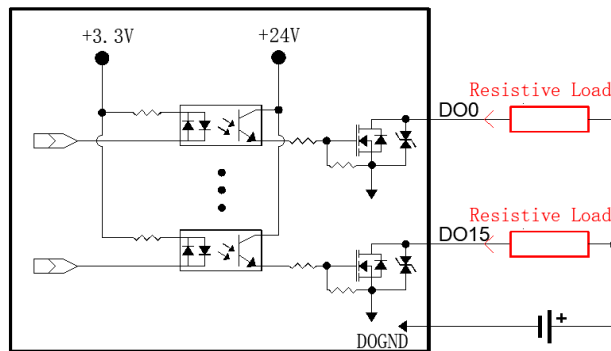

Figure 40 Wiring of resistive load

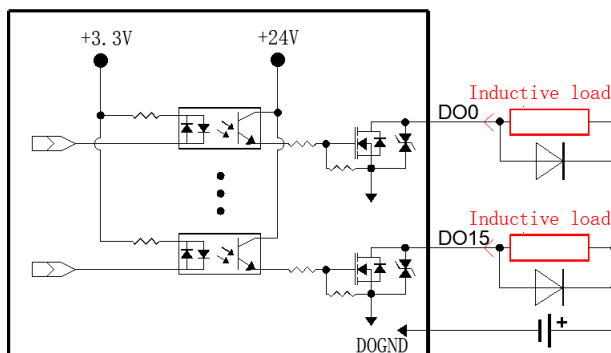

Figure 41 Wiring of inductive load



1. DO output current <math>< 500\text{mA}</math>;
2. DO load voltage <math>< 50\text{VDC}</math>;
3. Positive and negative power supply terminals can not connected to the DO signal terminal and DOGND directly.

2.6 NP-6135-JH3

The NP-6135-JH3 is one of the expansion model based on NP-6135 which integrates additional 4 USB ports, 2 CAN BUS ports, 8 channels of isolated DI and 8 channels of isolated DO. It is widely used in the field of AGV, robotics and motion control applications.

2.6.1 Key Features

- ◆ 2 x Intel GbE LAN controller
- ◆ 8 x USB, 1x USB 2.0 Type-A onboard for dongle
- ◆ 4 x RS232/485, RS485 supports automatic data flow control
- ◆ 8 x DI, 8 x DO
- ◆ 2 x CAN bus 2.0 A/B
- ◆ VGA and HDMI dual display ports
- ◆ 1 x miniPCIe slot can be extended to Wifi, 3G/4G
- ◆ Support Wall-mounted or DIN-Rail mounted
- ◆ -20 ~ 60°C wide temperature environment

2.6.2 Product Dimension

Unit: mm

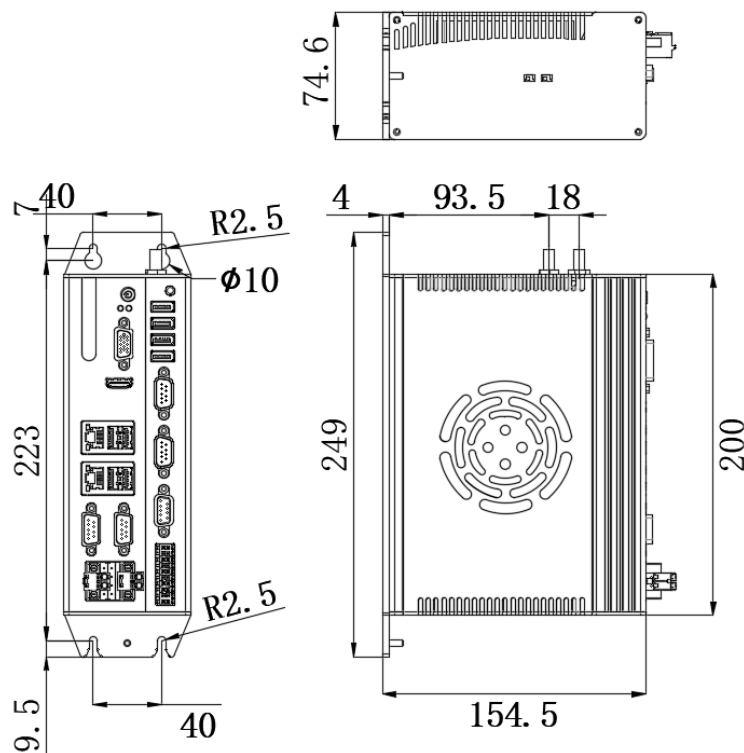
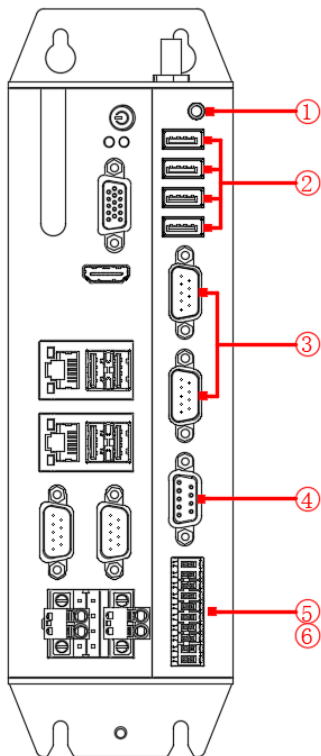

Figure 42 Dimension of NP-6135-JH3

2.6.3 Product Specifications

Model Name		NP-6135-JH3	
System	CPU	Intel® Core™ 10th/11th gen i9/i7/i5/i3 LGA1200 type desktop CPU	
	TDP	Max. 65W	
	BIOS	AMI UEFI 64Mbit	
	Memory	2 x SO-DIMM DDR4, max up to 32GB	
	Storage		1 x mSATA bay
			1 x M.2(B Key, Type 2280) bay support SATA
	USB		4 x USB3.0, 1 x USB2.0 Type A on the board for USB dongle
			4 x USB2.0 extended by PCIE x1.
	COM	4 x COM(DB-9), selectable to support RS232 or RS485 mode by the switch, RS485 support auto flow control, (ESD protection for RS232: Air gap ±8KV, Contact ±6KV)	
	CAN Bus	2 x CAN Bus 2.0A/B, 1 x DB9(Female)	
	DI	8 x DI NPN/PNP, isolated 3750 Vrms	
	DO	8 x DO, Transistor output, I _{max} :0.5A per channel, isolated 3750 Vrms	
	Ethernet	2 x Intel GbE LAN controller	
	VGA	Support up to 1920 x 1200 @ 60Hz	
	HDMI	Support up to 3840 x 2160 @ 60Hz	
Expansions	1 x Full-size PCIe Mini slot with SIM card holder(with USB signal)		
Watch Dog	1~255 levels programmable		
OS Support	Microsoft Windows	Windows 10	
	Linux	Ubuntu, CentOS, Debian	
Power	Voltage Input	DC12~24V ±10%, overcurrent, overvoltage and polarity inverse protection	
	Power Consumption	Max. 120W	
Chassis	Structure	Aluminum-magnesium alloy BOX with fan embedded to assist cooling, Wall-mounted or DIN-Rail fixing style.	
	Dimensions	(L)200mm x (W)154.5mm x (H)74.6mm	
	Net Weight	2.4Kg	
Environment	Work Temperature	-20°C ~ 60°C (-4°F~140°F) with air flow (SSD)	
	Storage Temperature	-40°C ~ 80°C (-40°F ~ 176°F) with air flow (SSD)	
	Relative Humidity	5~95% (Non-condensing)	
	Operating Vibration	5~500Hz, 1.5Grms@with SSD, Follow IEC60068-2-64	
	Operating Shock	20G peak acceleration(11ms duration) with SSD, Follow IEC60068-2-27	
	EMC	CE/FCC Class A	

2.6.4 Description of Interfaces



No.	Definition
1	Line out(optional)
2	USB
3	COM
4	CAN Bus
5	DI
6	DO

Figure 43 Interfaces of NP-6135-JH3

2.6.4.1 Lout interface

JH3 add-on board has an audio output interface, which is an optional item.

2.6.4.2 USB interface

JH3 add-on board expands 4 Type-A USB 3.0 ports via PCIe .

■ Pin definition of USB3.0 port:

Pin No.	Signal
1	VCC5
2	DATA-
3	DATA+
4	GND
5	SSRX-
6	SSRX+
7	GND
8	SSTX-
9	SSTX+



1. The 4 USB ports are extended via PCIe, so it can only be used after the PCIe driver is loaded by the OS.
2. 4 USB ports share the bandwidth of USB3.0, so when using 1 port of them, the speed of USB3.0 can be achieved, but if more than 1 ports are used, the bandwidth will be shared.

2.6.4.3 COM Ports

There are 2 additional COM ports on JH3 add-on board, they are COM3 and COM4. Both of the COM ports are the standard DB9 male terminal and can support RS232 or RS485 (selected through the DIP switch in the below of the housing, default setting is RS232).

■ Pin definition of COM port:

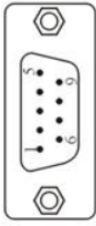
DB9 male terminal	Pin No.	Signal	
		RS232	RS485
	1	N.C.	N.C.
	2	RXD	A
	3	TXD	B
	4	N.C.	N.C.
	5	GND	GND
	6	N.C.	N.C.
	7	N.C.	N.C.
	8	N.C.	N.C.
	9	N.C.	N.C.

2.6.4.4 CAN Bus

A DB9 female terminal on the JH3 add-on board is reserved to be used to install the miniPCIE-CAN card.

■ Pin definition of CAN port:

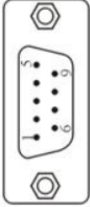
DB9 female terminal	Pin No.	Signal
		CAN BUS
	1	VCC
	2	CAN1_L
	3	GND
	4	CAN2_L
	5	GND
	6	GND
	7	CAN1_H
	8	CAN2_H
	9	VCC



1. There is a a 200Ω terminal resistor for each channel on the board, which can be turned on or off by toggle switch (default is on);
2. The miniPCIE-CAN is an optional part, and the port is not available if the card is not installed.

2.6.4.5 DIO

The JH3 add-on board provides 8 channels of isolated DI, 8 channels of isolated DO.

■ Pin definition of CAN port:

Pin No.	Signal	Description	Pin No.	Signal	Description
20	DOGND	Digital output ground common	19	DOGND	Digital output ground common
18	DO7	Digital output channel 7	17	DO6	Digital output channel 6
16	DO5	Digital output channel 5	15	DO4	Digital output channel 4
14	DO3	Digital output channel 3	13	DO2	Digital output channel 2
12	DO1	Digital output channel 1	11	DO0	Digital output channel 0
10	DICOM	Digital input common	9	DIGND	Digital output ground common
8	DI7	Digital input channel 7	7	DI6	Digital input channel 6
6	DI5	Digital input channel 5	5	DI4	Digital input channel 4
4	DI3	Digital input channel 3	3	DI2	Digital input channel 2
2	DI1	Digital input channel 1	1	DI0	Digital input channel 0

2.6.4.5.3 DI

The JH3 add-on board provides 8 channels of isolated digital inputs (isolation voltage 3750Vrms), the maximum allowable voltage cannot be exceeded DC30V. Because of the internal circuit adopts bidirectional optocoupler isolation, it is compatible with PNP and NPN wiring solution. The reference wiring diagrams are as follows:

➤ NPN connection in wet contact way:

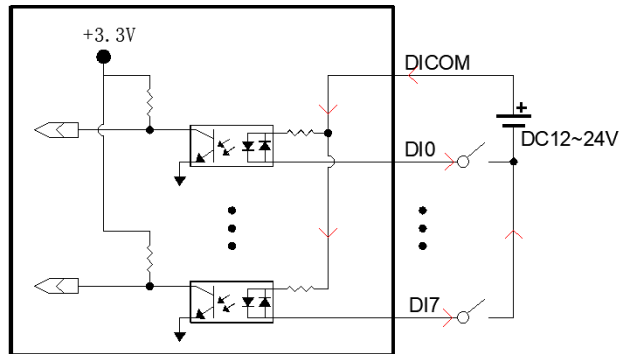

Figure 44 DI NPN wiring solution

➤ PNP connection in wet contact way:

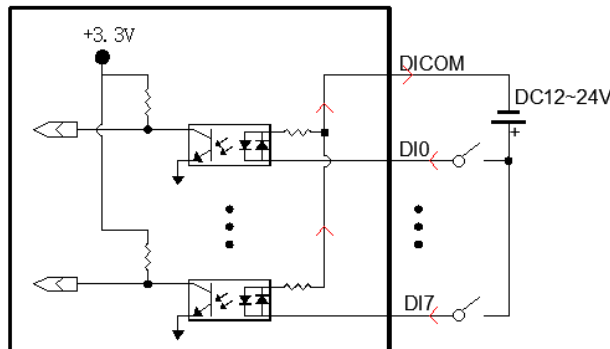

Figure 45 DI PNP wiring solution

- NPN connection in dry contact way:

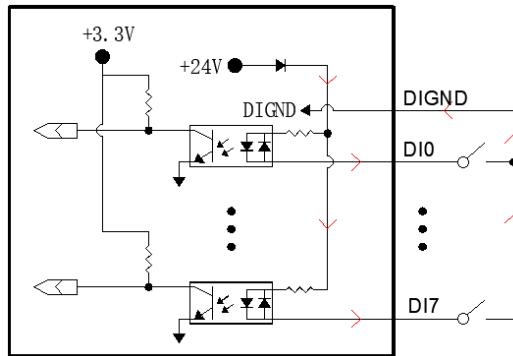

Figure 46 DI NPN wiring solution

- PNP connection in dry contact way:

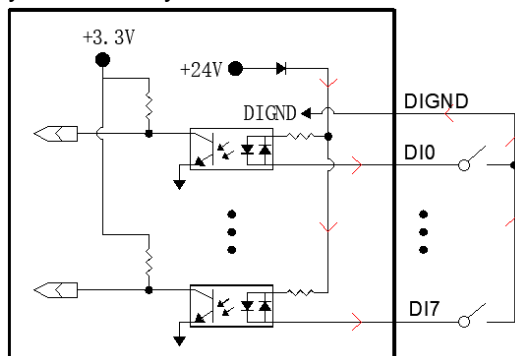

Figure 47 DI PNP wiring solution

2.6.4.5.4 DO

The JH3 add-on board provides 8 channels of Digital Output channels, transistor output, I_{max} : 500mA, V_{max} : 50V. Please remind that a diode should be connected in parallel for freewheeling when external inductive load is connected.

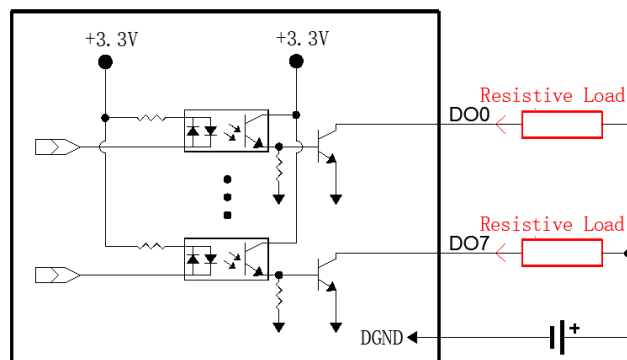

Figure 48 Wiring of resistive load

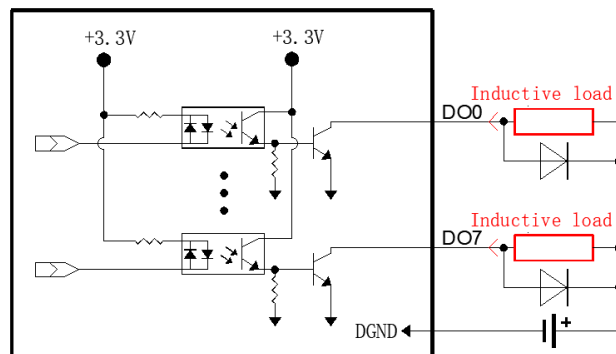

Figure 49 Wiring of inductive load



1. DO output current <math>< 500\text{mA}</math>;
2. DO load voltage <math>< 50\text{VDC}</math>;
3. Positive and negative power supply terminals can not connected to the DO signal terminal and DOGND directly.

2.7 NP-6135-JH4

The NP-6135-JH4 is a product combined by NP-6135 basic module and JH4 add-on board, in addition of the functions supported by the NP-6135 basic module, additional 8 channels of RS485 and 8 channels of digital input, 4 channels of relay output are supported by JH4 add-on board. The DI and DO can be accessed via Modbus RTU protocol. In addition, there is two led status for each channel to display the data sending and receiving status, termination resistors can be turned on or off by the switch for each channel.

2.7.1 Key Features

- ◆ 2 x Intel GbE LAN controller
- ◆ 4 x USB3.0, 1x USB 2.0 Type-A onboard for dongle
- ◆ 2 x RS232/485, 8 x RS485, RS485 supports automatic data flow control
- ◆ 8 x DI, 4 x relay DO
- ◆ VGA and HDMI dual display ports
- ◆ 1 x miniPCIe slot can be extended to Wifi, 3G/4G
- ◆ Support Wall-mounted or DIN-Rail mounted
- ◆ -20 ~ 60°C wide temperature environment

2.7.2 Product Dimension

Unit: mm

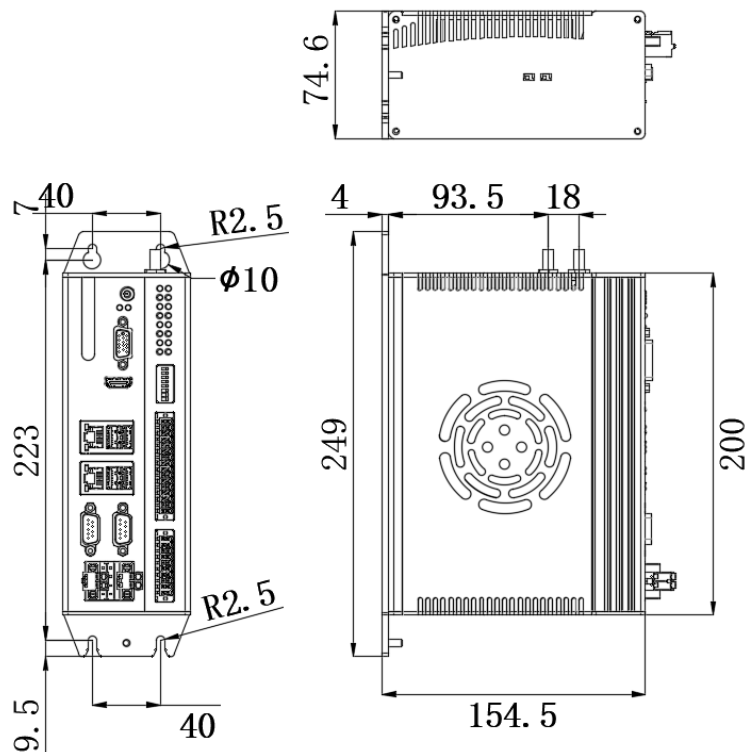
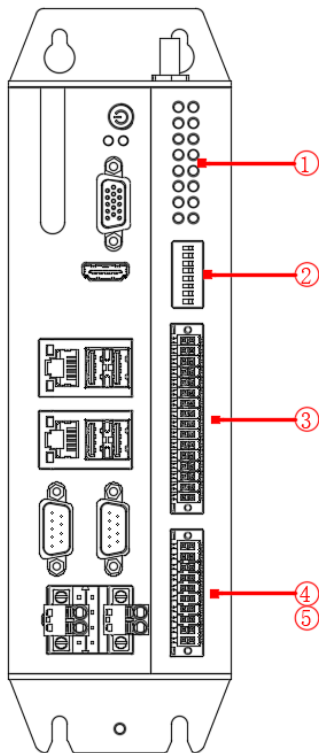

Figure 50 Dimension of NP-6135-JH4

2.7.3 Product Specifications

Model Name		NP-6135-JH4
System	CPU	Intel® Core™ 10th/11th gen i9/i7/i5/i3 LGA1200 type desktop CPU
	TDP	Max. 65W
	BIOS	AMI UEFI 64Mbit
	Memory	2 x SO-DIMM DDR4, max up to 32GB
	Storage	1 x mSATA bay
		1 x M.2(B Key, Type 2280) bay support SATA
	USB	4 x USB3.0, 1 x USB2.0 Type A on the board for USB dongle
	COM	2 x COM(DB-9), selectable to support RS232 or RS485 mode by the switch, 8 x RS485(Phoenix Contators), RS485 support auto flow control, (ESD protection for RS232: Air gap ±8KV, Contact ±6KV)
	DI	8 x DI NPN/PNP, isolated 2500 Vrms
	DO	4 x Relay DO, Normally Open, 30VDC(Imax: 1.0A)/60VDC(Imax: 0.3A)/125VAC(Imax: 0.5A)
	Ethernet	2 x Intel GbE LAN controller
	VGA	Support up to 1920 x 1200 @ 60Hz
	HDMI	Support up to 3840 x 2160 @ 60Hz
	Expansions	1 x Full-size PCIe Mini slot with SIM card holder(with USB signal)
	Watch Dog	1~255 levels programmable
OS Support	Microsoft Windows	Windows 10
	Linux	Ubuntu, CentOS, Debian
Power	Voltage Input	DC12~24V ±10%, overcurrent, overvoltage and polarity inverse protection
	Power Consumption	Max. 120W
Chassis	Structure	Aluminum-magnesium alloy BOX with fan embedded to assist cooling, Wall-mounted or DIN-Rail fixing style.
	Dimensions	(L)200mm x (W)154.5mm x (H)74.6mm
	Net Weight	2.3Kg
Environment	Work Temperature	-20°C ~ 60°C (-4°F~140°F) with air flow (SSD)
	Storage Temperature	-40°C ~ 80°C (-40°F ~ 176°F) with air flow (SSD)
	Relative Humidity	5~95% (Non-condensing)
	Operating Vibration	5~500Hz, 1.5Grms@with SSD, Follow IEC60068-2-64
	Operating Shock	20G peak acceleration(11ms duration) with SSD, Follow IEC60068-2-27
	EMC	CE/FCC Class A

2.7.4 Description of Interfaces



No.	Definition
1	Serial port transceiver status light
2	RS485 terminal resistance DIP switch
3	RS485 port
4	DI
5	DO

Figure 51 Interfaces of NP-6135-JH4

2.7.4.1 RS485 COM Port

JH4 add-on board provides 8 channels of isolated RS485 (COM3~COM10) by 32-pin phoenix terminals.

32 pin phoenix terminals are defined as follows:

Pin No.	Signal	Description	Pin No.	Signal	Description
32	GND8	COM10 RS485 GND	31	GND8	COM10 RS485 GND
30	B8	COM10 RS485 Data-	29	A8	COM10 RS485 Data+
28	GND7	COM9 RS485 GND	27	GND7	COM9 RS485 GND
26	B7	COM9 RS485 Data-	25	A7	COM9 RS485 Data+
24	GND6	COM8 RS485 GND	23	GND6	COM8 RS485 GND
22	B6	COM8 RS485 Data-	21	A6	COM8 RS485 Data+
20	GND5	COM7 RS485 GND	19	GND5	COM7 RS485 GND
18	B5	COM7 RS485 Data-	17	A5	COM7 RS485 Data+
16	GND4	COM6 RS485 GND	15	GND4	COM6 RS485 GND
14	B4	COM6 RS485 Data-	13	A4	COM6 RS485 Data+
12	GND3	COM5 RS485 GND	11	GND3	COM5 RS485 GND
10	B3	COM5 RS485 Data-	9	A3	COM5 RS485 Data+
8	GND2	COM4 RS485 GND	7	GND2	COM4 RS485 GND
6	B2	COM4 RS485 Data-	5	A2	COM4 RS485 Data+
4	GND1	COM3 RS485 GND	3	GND1	COM3 RS485 GND
2	B1	COM3 RS485 Data-	1	A1	COM3 RS485 Data+

1. COM3~COM10 RS485 termination resistors setting

	Pin	Function
	8	When ON, COM10 enables 120 ohm termination resistors, OFF is not available
	7	When ON, COM9 enables 120 ohm termination resistors, OFF is not available
	6	When ON, COM8 enables 120 ohm termination resistors, OFF is not available
	5	When ON, COM7 enables 120 ohm termination resistors, OFF is not available
	4	When ON, COM6 enables 120 ohm termination resistors, OFF is not available
	3	When ON, COM5 enables 120 ohm termination resistors, OFF is not available
	2	When ON, COM4 enables 120 ohm termination resistors, OFF is not available
	1	When ON, COM3 enables 120 ohm termination resistors, OFF is not available

2. COM3~COM10 RS485 data transceiver status light

	LED		Function
	Tx8	Rx8	COM10 Tx8 blinks when sending data, Rx8 blinks when receiving data
	Tx7	Rx7	COM9 Tx7 blinks when sending data, Rx7 blinks when receiving data
	Tx6	Rx6	COM8 Tx6 blinks when sending data, Rx6 blinks when receiving data
	Tx5	Rx5	COM7 Tx5 blinks when sending data, Rx5 blinks when receiving data
	Tx4	Rx4	COM6 Tx4 blinks when sending data, Rx4 blinks when receiving data
	Tx3	Rx3	COM5 Tx3 blinks when sending data, Rx3 blinks when receiving data
	Tx2	Rx2	COM4 Tx2 blinks when sending data, Rx2 blinks when receiving data
	Tx1	Rx1	COM3 Tx1 blinks when sending data, Rx1 blinks when receiving data

2.7.4.2 IO Signal terminals

JH4 add-on board provides 8 channels of isolated DI and 4 channels of relay outputs via a 20-pin phoenix terminal. The DI supports wet contact or NPN access and the user can access the status of the DI/DO via Modbus RTU communication protocol, the pin definition list as the below table shows.

Pin No.	Signal	Description	Pin No.	Signal	Description
20	DOCOM3	Relay output channel 3 common	19	DO3	Relay output channel 3
18	DOCOM2	Relay output channel 2 common	17	DO2	Relay output channel 2
16	DOCOM1	Relay output channel 1 common	15	DO1	Relay output channel 1
14	DOCOM0	Relay output channel 0 common	13	DO0	Relay output channel 0
12	DICOM	Digital input common	11	DICOM	Digital input common
10	DIGND	Digital input ground common	9	DIGND	Digital input ground common
8	DI7	Digital input channel 7	7	DI6	Digital input channel 6
6	DI5	Digital input channel 5	5	DI4	Digital input channel 4
4	DI3	Digital input channel 3	3	DI2	Digital input channel 2
2	DI1	Digital input channel 1	1	DI0	Digital input channel 0

2.7.4.2.1 DI

JH4 add-on board provides 8 channels of isolated digital inputs (isolation voltage 2500Vrms), with an optocoupler conduction voltage of DC12V~24V, the maximum allowable voltage cannot be exceeded DC30V. Because of the internal circuit adopts bidirectional optocoupler isolation, it is compatible with PNP and NPN wiring solutions. The wiring diagrams are as follows:

- NPN connection in wet contact way:

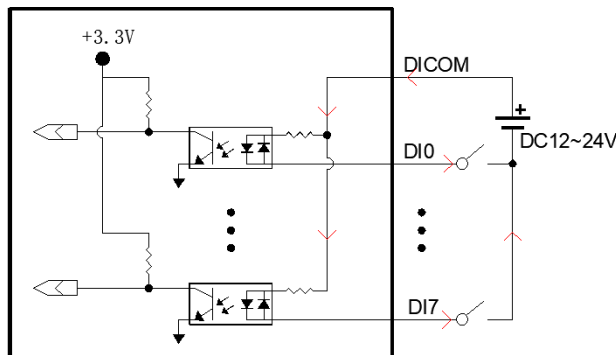

Figure 52 DI NPN wiring solution

- PNP connection in wet contact way:

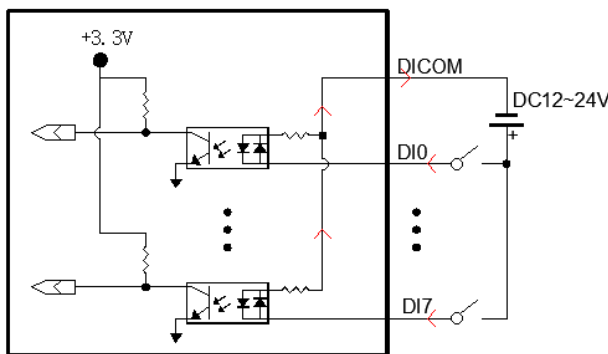

Figure 53 DI PNP wiring solution

- NPN connection in dry contact way:

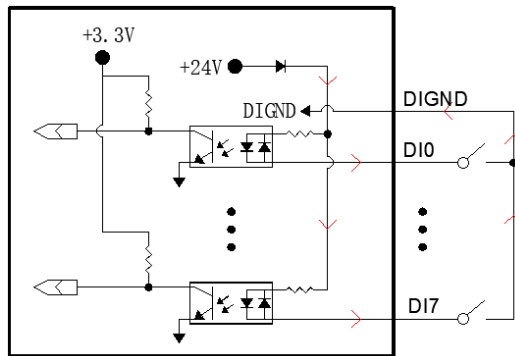

Figure 54 DI NPN wiring solution

- PNP connection in dry contact way:

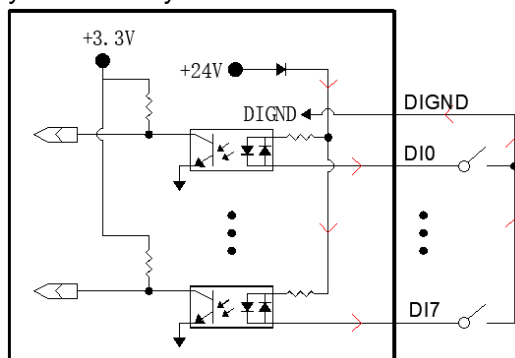

Figure 55 DI PNP wiring solution

2.7.4.2.2 DO

JH4 add-on board provides 4 channels of normally open relay outputs, relay size: 30VDC (max. current: 1.0A)/60VDC (max. current: 0.3A)/125VAC (max. current: 0.5A. For inductive loads a discharge diode must be connected in parallel between the output signal and DOGND. The reference wiring method is as follows:

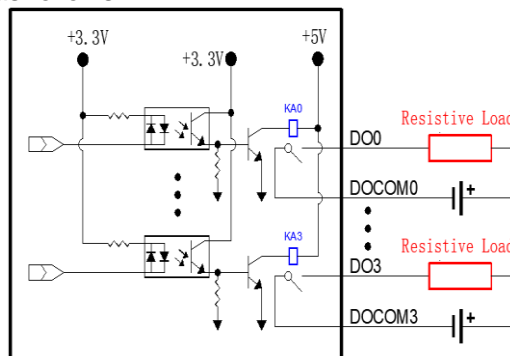

Figure 56 Wiring of resistive load

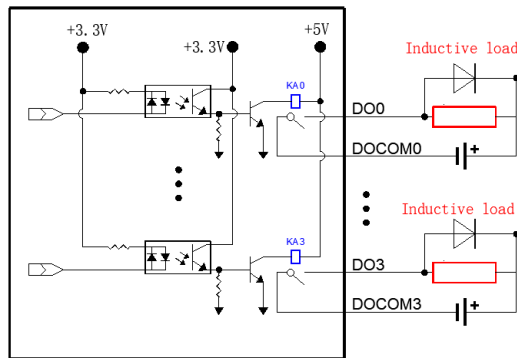

Figure 57 Wiring of inductive load



The DO output load can't exceed the maximum allowable current and voltage of the relay, otherwise the relay will be damaged.

2.7.4.2.3 Modbus RTU Register Definitions

Target to be easily to read and write the DI and DO status, the status of DI and DO channels on the JH4 add-on board can be accessed via standard Modbus RTU protocol. When using Modbus RTU communication, the JH4 works as a slave device. The default address is 1, and the COM port used on the PC is COM11.

1. Default communication parameters

- Baud rate: 115200bps
- Data bit: 8bit
- Stop bit: 1bit
- Parity bit: None

The communication parameters can be read or changed by the according holding register in the format of 0xPMRB:

- P (Parity) means parity
 - P=1 means none parity
 - P=2 means odd parity
 - P=3 means even parity
- M: communication mode, 0: RTU;
- R (Reserve): retain default values, 0: 1 stop bit, 8 data bits;
- B (Baudrate): baud rate index,

Refer to the following table in detail:

Baud rate	Set values					
	No parity bit		Odd parity bit		Even parity bit	
	Hexadecimal	Decimal	Hexadecimal	Decimal	Hexadecimal	Decimal
9600	0x1001	4097	0x2001	8193	0x3001	12289
19200	0x1002	4098	0x2002	8194	0x3002	12290
38400	0x1003	4099	0x2003	8195	0x3003	12291
57600	0x1004	4100	0x2004	8196	0x3004	12292
76800	0x1005	4101	0x2005	8197	0x3005	12293
115200	0x1006	4102	0x2006	8198	0x3006	12294

NOTE: Default communication parameter is 0x1006: RTU communication mode, baud rate 115200, 1 stop bit, 8 data bits, no parity bits.

2. Hot start function settings

The hot start function can be enabled or disabled by setting of 40012 register, set 1 to 40012, the hot start will be enabled and the last output state will be saved to the retentive memory, which will be reloaded after the system is restarted. While set 0 to 40012, the cold start will be enabled, and the state of the output will be lost after the system is restarted.

3. Settings of the relay output

The state of 4 channels of the relay output can be set by the coil status register from 00001 to 00004 or by the according bit in the holding register 40021. Set to 1 to turn on the relay, while 0 to turn off the relay.

refer to the following table for set values and output states in 40021:

DO7	DO6	DO5	DO4	DO3	DO2	DO1	DO0	Set value
X	X	X	X	0	0	0	0	0x0000
X	X	X	X	0	0	0	1	0x0001
X	X	X	X	0	0	1	0	0x0002
X	X	X	X	0	0	1	1	0x0003
X	X	X	X	0	1	0	0	0x0004
X	X	X	X	0	1	0	1	0x0005
X	X	X	X	0	1	1	0	0x0006
X	X	X	X	0	1	1	1	0x0007
X	X	X	X	1	0	0	0	0x0008
X	X	X	X	1	0	0	1	0x0009
X	X	X	X	1	0	1	0	0x000A
X	X	X	X	1	0	1	1	0x000B
X	X	X	X	1	1	0	0	0x000C
X	X	X	X	1	1	0	1	0x000D
X	X	X	X	1	1	1	0	0x000E
X	X	X	X	1	1	1	1	0x000F

NOTE: The set command must not be bigger than 0x00FF, otherwise it is invalid.x means the current product does not support

4. Digital inputs and filter setting

The digital input status can be read by the input register from 10001 to 10008 or by the holding register 40023. The according bit is 1 when the DI is active, while is 0 when inactive.

There is a separate holding register for each digital input channel to set the filter time, they are from 40031 to 40038, time unit is ms, maximum is 20ms.

5. DO Control registers

Function Code: 01/05

NO.	Address	Signal	Remark
1	00001	DO0	Write 1 to open the relay, write 0 to close it
2	00002	DO1	Write 1 to open the relay, write 0 to close it
3	00003	DO2	Write 1 to open the relay, write 0 to close it
4	00004	DO3	Write 1 to open the relay, write 0 to close it

6. DI Input registers

Function Code: 02

NO.	Address	Signal	Remark
1	10001	DI0	1 when active, 0 when inactive.
2	10002	DI1	1 when active, 0 when inactive.
3	10003	DI2	1 when active, 0 when inactive.

4	10004	DI3	1 when active, 0 when inactive.
5	10005	DI4	1 when active, 0 when inactive.
6	10006	DI5	1 when active, 0 when inactive.
7	10007	DI6	1 when active, 0 when inactive.
8	10008	DI7	1 when active, 0 when inactive.

7. Parameter holding registers

Function Code : 03/06

NO	Address	Description of data	R/W	Remark
1	40001	Device ID	R	
2	40002	Device name character 1	R	
3	40003	Device name character 2	R	
4	40004	Device name character 3	R	
5	40005	Device name character 4	R	
6	40006	Device name character 5	R	
7	40007	Device hardware version number	R	
8	40008	Device hardware release number	R	
9	40009	Device firmware master version number	R	
10	40010	Device firmware compilation version number	R	
11	40011	Communication parameter	R	
12	40012	Hot start setting	RW	
13	40013	Reserved	-	
14	40014	Reserved	-	
15	40015	Reserved	-	
16	40016	Reserved	-	
17	40017	Reserved	-	
18	40018	Reserved	-	
19	40019	Reserved	-	
20	40020	Reserved	-	
21	40021	DO's output	RW	DO status acquisition and output control
22	40022	Reserved	-	
23	40023	Input status of DI	R	Each bit represents 1 input
24	40024	Reserved	-	

25	40025	Reserved	-	
26	40026	Reserved	-	
27	40027	Reserved	-	
28	40028	Reserved	-	
29	40029	Reserved	-	
30	40030	Reserved	-	
31	40031	DI0 filter time	RW	Unit ms, no filtering when 0, Max.20ms
32	40032	DI1 filter time	RW	Unit ms, no filtering when 0, Max.20ms
33	40033	DI2 filter time	RW	Unit ms, no filtering when 0, Max.20ms
34	40034	DI3 filter time	RW	Unit ms, no filtering when 0, Max.20ms
35	40035	DI4 filter time	RW	Unit ms, no filtering when 0, Max.20ms
36	40036	DI5 filter time	RW	Unit ms, no filtering when 0, Max.20ms
37	40037	DI6 filter time	RW	Unit ms, no filtering when 0, Max.20ms
38	40038	DI7 filter time	RW	Unit ms, no filtering when 0, Max.20ms
39	40039	Reserved	-	
40	40040	Reserved	-	

2.8 NP-6135-8PoE

The NP-6135-8POE is a product combined by NP-6135 basic module and 8POE add-on board, in addition of the functions supported by the NP-6135 basic module, eight PoE ports are extended in the H6 add-on board.

The product is widely used in the field of vision inspection, defect detection, image recognition and material sorting.

2.8.1 Key Features

- ◆ 2 x Intel GbE LAN controller
- ◆ 8 x Intel GbE PoE LAN controller
- ◆ 4 x USB3.0, 1x USB 2.0 Type-A onboard for dongle
- ◆ 2 x RS232/485, RS485 supports automatic data flow control
- ◆ VGA and HDMI dual display ports
- ◆ 1 x miniPCIe slot can be extended to Wifi, 3G/4G
- ◆ Support Wall-mounted or DIN-Rail mounted
- ◆ -20 ~ 60°C wide temperature environment

2.8.2 Product Dimension

Unit: mm

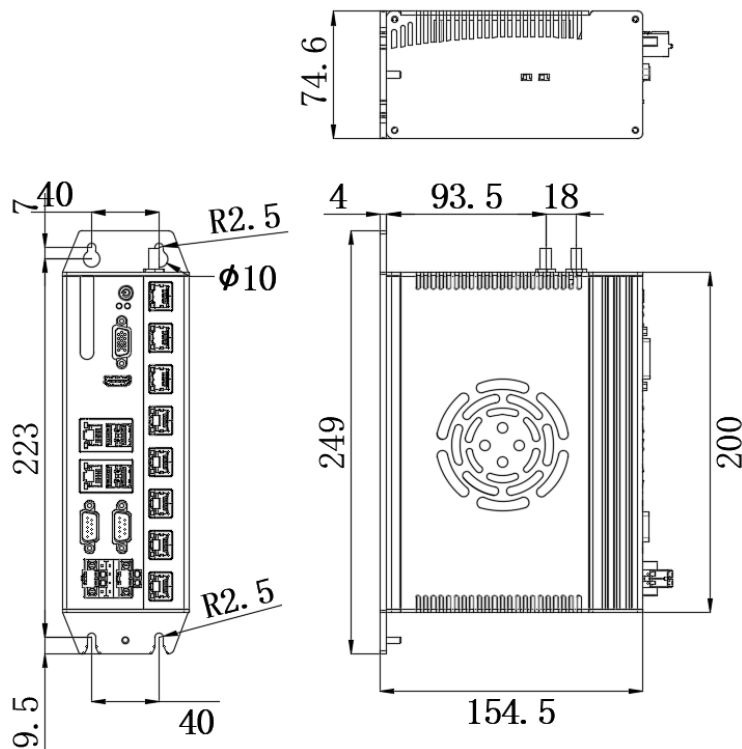
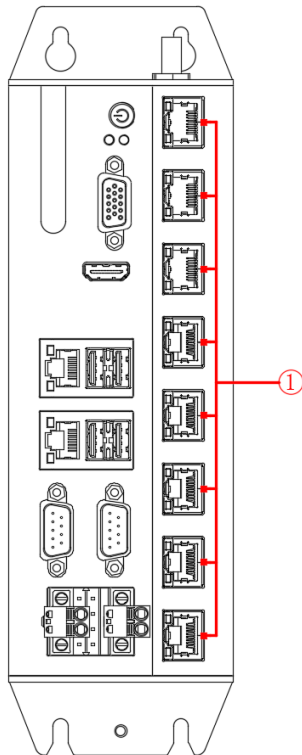

Figure 58 Dimension of NP-6135-8PoE

2.8.3 Product Specifications

Model Name		NP-6135-8POE	
System	CPU	Intel® Core™ 10th/11th gen i9/i7/i5/i3 LGA1200 type desktop CPU	
	TDP	Max. 65W	
	BIOS	AMI UEFI 64Mbit	
	Memory	2 x SO-DIMM DDR4, max up to 32GB	
	Storage		1 x mSATA bay
			1 x M.2(B Key, Type 2280) bay support SATA
	USB	4 x USB3.0, 1 x USB2.0 Type A on the board for USB dongle	
	COM	2 x COM(DB-9), selectable to support RS232 or RS485 mode by the switch, RS485 support auto flow control, (ESD protection for RS232: Air gap ±8KV, Contact ±6KV)	
	Ethernet	2 x Intel GbE LAN controller	
	PoE	8 x Intel GbE PoE LAN controller, max. 15W per channel	
	VGA	Support up to 1920 x 1200 @ 60Hz	
	HDMI	Support up to 3840 x 2160 @ 60Hz	
	Expansions	1 x Full-size PCIe Mini slot with SIM card holder(with USB signal)	
Watch Dog	1~255 levels programmable		
OS Support	Microsoft Windows	Windows 10	
	Linux	Ubuntu, CentOS, Debian	
Power	Voltage Input	DC12~24V ±10%, overcurrent, overvoltage and polarity inverse protection,	
	Power Consumption	Max. 250W	
Chassis	Structure	Aluminum-magnesium alloy BOX with fan embedded to assist cooling, Wall-mounted or DIN-Rail fixing style.	
	Dimensions	(L)200mm x (W)154.5mm x (H)74.6mm	
	Net Weight	2.6Kg	
Environment	Work Temperature	-20°C ~ 60°C (-4°F~140°F) with air flow (SSD)	
	Storage Temperature	-40°C ~ 80°C (-40°F ~ 176°F) with air flow (SSD)	
	Relative Humidity	5~95% (Non-condensing)	
	Operating Vibration	5~500Hz, 1.5Grms@with SSD, Follow IEC60068-2-64	
	Operating Shock	20G peak acceleration(11ms duration) with SSD, Follow IEC60068-2-27	
	EMC	CE/FCC Class A	

2.8.4 Description of Interfaces



No.	Name
1	PoE LAN

Figure 59 Interfaces of NP-6135-8PoE

2.8.4.1 PoE LAN

There are eight PoE Gigabit Ethernet ports: from LAN3 to LAN10. The maximum power of each channel is 15W.

- Pin definition of PoE LAN connector:

Pin No.	Signal	
	100BASE-TX	1000BASE-T
1	TX+	TRD+(0)
2	TX-	TRD-(0)
3	RX+	TRD+(1)
4	N.C.	TRD+(2)
5	N.C.	TRD-(2)
6	RX-	TRD-(1)
7	N.C.	TRD+(3)
8	N.C.	TRD-(3)

There are two status leds in the RJ45 connector indicate the status of the link and transmit separately. Link led is on when link successfully, and when the network is working in the 1000Mbps, the transmit led is blinking in orange color and in green color when working in the other speed.

Type	Parameters
Network Type	1000BASE-T/100BASE-TX/10BASE-T
Transmission Speed*	1000M/100M/10Mbps
Maximum Cable Distance	100m/segment
NIC Type	Intel® Ethernet Controller

*When the transmission speed is 1000Mbps, a network cable of at least CAT 5e is required.



- 1. PoE LAN cable 1-2 are positive, 3-6 are negative and cannot be shorted;
 - 2. No crossover PoE LAN cable allowed;
 - 3. CAT-6 or higher PoE LAN cable recommended.
-

2.9 NP-6135-L2

NP-6135-L2 is designed for the PLC, process control and industrial automation industry and can be extended with additional 2 LAN ports via miniPCIe slot.

2.9.1 Key Features

- ◆ 4 x Intel GbE LAN controller
- ◆ 4 x USB3.0, 1x USB 2.0 Type-A onboard for dongle
- ◆ 2 x RS232/485, RS485 supports automatic data flow control
- ◆ VGA and HDMI dual display ports
- ◆ Support Wall-mounted or DIN-Rail mounted
- ◆ -20 ~ 60°C wide temperature environment

2.9.2 Product Dimension

Unit: mm

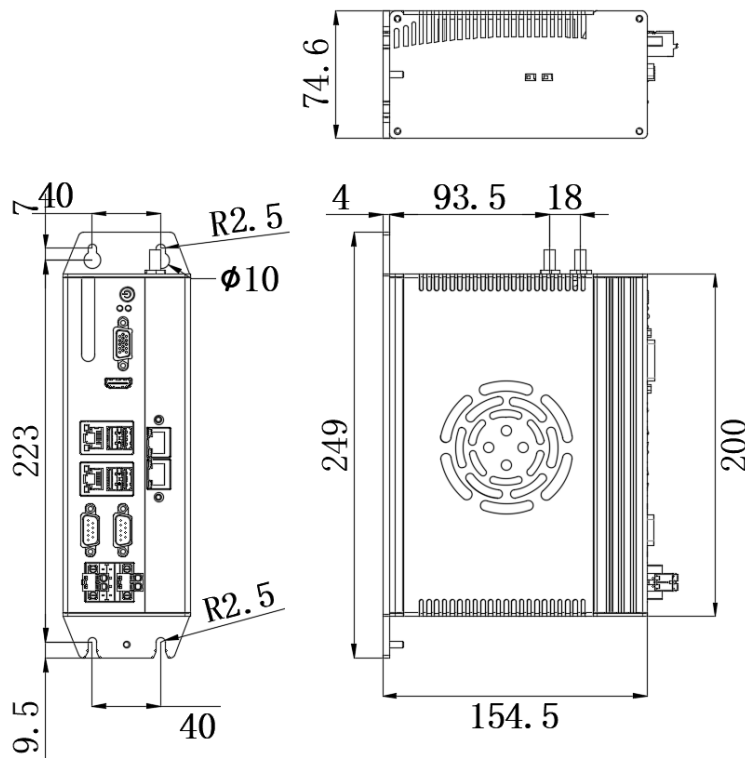
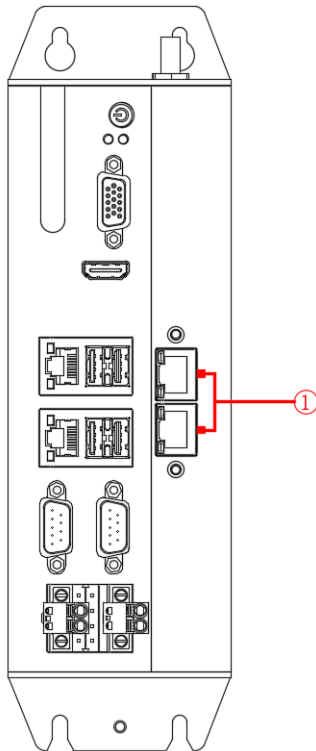

Figure 60 Dimension of NP-6135-L2

2.9.3 Product Specifications

Model Name		NP-6135-L2
System	CPU	Intel® Core™ 10th/11th gen i9/i7/i5/i3 LGA1200 type desktop CPU
	TDP	Max. 65W
	BIOS	AMI UEFI 64Mbit
	Memory	2 x SO-DIMM DDR4, max up to 32GB
	Storage	1 x mSATA bay
		1 x M.2(B Key, Type 2280) bay support SATA
	USB	4 x USB3.0, 1 x USB2.0 Type A on the board for USB dongle
	COM	2 x COM(DB-9), selectable to support RS232 or RS485 mode by the switch, RS485 support auto flow control, (ESD protection for RS232: Air gap ±8KV, Contact ±6KV)
	Ethernet	4 x Intel GbE LAN controller
	VGA	Support up to 1920 x 1200 @ 60Hz
	HDMI	Support up to 3840 x 2160 @ 60Hz
	Watch Dog	1~255 levels programmable
OS Support	Microsoft Windows	Windows 10
	Linux	Ubuntu, CentOS, Debian
Power	Voltage Input	DC12~24V ±10%, overcurrent, overvoltage and polarity inverse protection
	Power Consumption	Max. 120W
Chassis	Structure	Aluminum-magnesium alloy BOX with fan embedded to assist cooling, Wall-mounted or DIN-Rail fixing style.
	Dimensions	(L)200mm x (W)154.5mm x (H)74.6mm
	Net Weight	2.0Kg
Environment	Work Temperature	-20°C ~ 60°C (-4°F~140°F) with air flow (SSD)
	Storage Temperature	-40°C ~ 80°C (-40°F ~ 176°F) with air flow (SSD)
	Relative Humidity	5~95% (Non-condensing)
	Operating Vibration	5~500Hz, 1.5Grms@with SSD, Follow IEC60068-2-64
	Operating Shock	20G peak acceleration(11ms duration) with SSD, Follow IEC60068-2-27
EMC	CE/FCC Class A	

2.9.4 Description of Interfaces



No.	Definition
1	Extended LAN Ports

Figure 61 Interfaces of NP-6135-L2

2.9.4.1 LAN

Additional 2 Intel GbE Ethernet RJ45 interfaces are extended via miniPCle slot, they are LAN3 and LAN4. Therefore, there is no miniPCIE slot on the board to extend the other interfaces.

- The definitions of RJ45 pins are as follows:

Pin No.	Signal	
	100BASE-TX	1000BASE-T
1	TX+	TRD+(0)
2	TX-	TRD-(0)
3	RX+	TRD+(1)
4	N.C.	TRD+(2)
5	N.C.	TRD-(2)
6	RX-	TRD-(1)
7	N.C.	TRD+(3)
8	N.C.	TRD-(3)

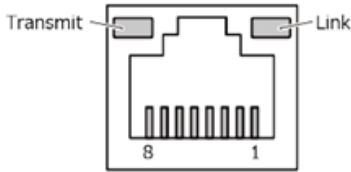

There are two status indicators, links status on the right side, data transmission status on the left side. The Link light is green and always on when the network is connected normally; the Transmit light flashes green when 100 megabit data is being transferred; the Transmit light flashes orange when gigabit data is being transferred.

Type	Parameters
Network Type	1000BASE-T/100BASE-TX/10BASE-T
Transmission Speed*	1000M/100M/10Mbps
Maximum Cable Distance	100m/segment
NIC Type	Intel® Ethernet Controller

*When the transmission speed is 1000Mbps, a network cable of at least CAT 5e is required.

2.10 NP-6135-CAN2

NP-6135-CAN2 is designed for the PLC, AGV, Service robot and AGV controller applications. 2 independent CAN buse ports(DB9 female) can be extended via miniPCle slot, 120 ohm resistors on the board can be set via DIP switches.

2.10.1 Key Features

- ◆ 2 x Intel GbE LAN controller
- ◆ 4 x USB3.0, 1x USB 2.0 Type-A onboard for dongle
- ◆ 2 x RS232/485, RS485 supports automatic data flow control
- ◆ 2 x CAN bus 2.0 A/B
- ◆ VGA and HDMI dual display ports
- ◆ Support Wall-mounted or DIN-Rail mounted
- ◆ -20 ~ 60°C wide temperature environment

2.10.2 Product Dimension

Unit: mm

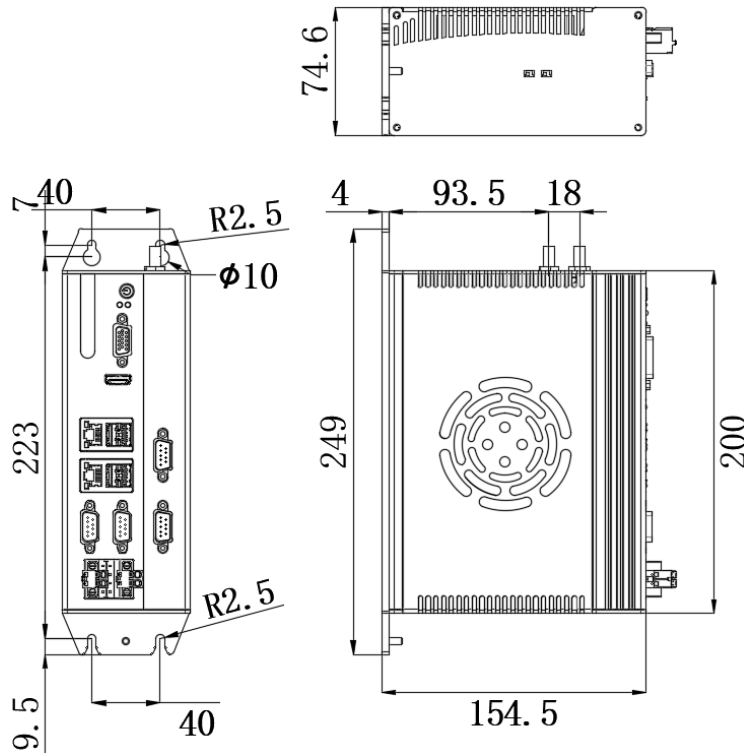
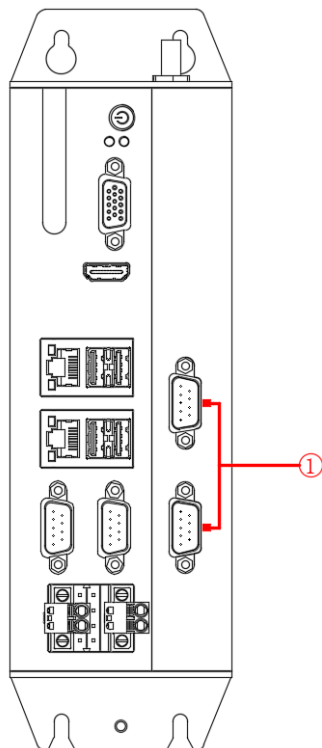

Figure 62 Dimension of NP-6135-CAN2

2.10.3 Product Specifications

Model Name		NP-6135-CAN2
System	CPU	Intel® Core™ 10th/11th gen i9/i7/i5/i3 LGA1200 type CPU
	TDP	Max. 65W
	BIOS	AMI UEFI 64Mbit
	Memory	2 x 260-pin SODIMM DDR4, max up to 32GB
	Storage	1 x mSATA bay
		1 x M.2(B Key, Type 2280) bay support SATA
	USB	4 x USB3.0, 1 x USB2.0 Type A on the board for USB dongle
	COM	2 x COM(DB-9), selectable to support RS232 or RS485 mode by the switch, RS485 support auto flow control, (ESD protection for RS232: Air gap ±8KV, Contact ±6KV)
	Ethernet	2 x Intel GbE LAN controller
	VGA	Support up to 1920 x 1200 @ 60Hz
	HDMI	Support up to 3840 x 2160 @ 60Hz
	CAN Bus	2 x CAN Bus 2.0 A/B
Watch Dog	1~255 levels programmable	
OS Support	Microsoft Windows	Windows 10
	Linux	Ubuntu, CentOS, Debian
Power	Voltage Input	DC12~24V ±10%, overcurrent, overvoltage and polarity inverse protection
	Power Consumption	Max. 120W
Chassis	Structure	Aluminum-magnesium alloy BOX with fan embedded to assist cooling, Wall-mounted or DIN-Rail fixing style.
	Dimensions	(L)200mm x (W)154.5mm x (H)74.6mm
	Net Weight	2.0Kg
Environment	Work Temperature	-20°C ~ 60°C (-4°F~140°F) with air flow (SSD)
	Storage Temperature	-40°C ~ 80°C (-40°F ~ 176°F) with air flow (SSD)
	Relative Humidity	5~95% (Non-condensing)
	Operating Vibration	5~500Hz, 1.5Grms@with SSD, Follow IEC60068-2-64
	Operating Shock	20G peak acceleration(11ms duration) with SSD, Follow IEC60068-2-27
	EMC	CE/FCC Class A

2.10.4 Description of Interfaces



No.	Definition
1	CAN bus 2.0 A/B interface

Figure 63 Interfaces of NP-6135-CAN2

2.10.4.1 CAN Bus

1 or 2 channels of CAN2.0 A/B bus are extended via miniPCIe slot on the board.

- The definitions of DB9 male interface are as follows:

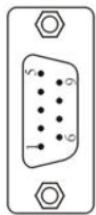
DB9 male interface	Pin No.	Signal
		CAN BUS
	1	N.C.
	2	CAN_L
	3	GND
	4	N.C.
	5	N.C.
	6	GND
	7	CAN_H
	8	N.C.
	9	N.C.

3 System Setup

This chapter mainly introduces how to setup hardware components drivers.

3.1.1 Hardware Setup

3.1.1.1 Attaching wall-mounted part

Use 2 or 4 screws on the back to attach the wall-mounted part, please refer to the below figure.

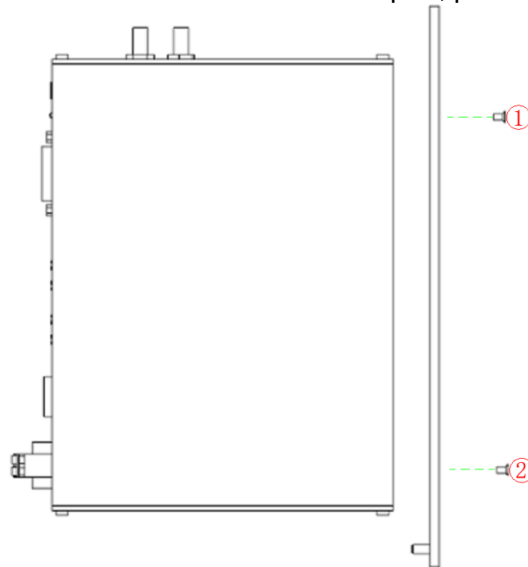

Figure 64 Attach the wall-mount part



1. Do not tighten screws with excess force.
2. Screw holes may be damaged if screws are tightened with a torque greater than the specified torque. The specified tightening torque is 5-6 kgf·cm.

3.1.1.2 Attaching DIN-Rail mounted part

Use 4 screws on the back to attach the DIN-Rail mounted part, please refer to the below figure.

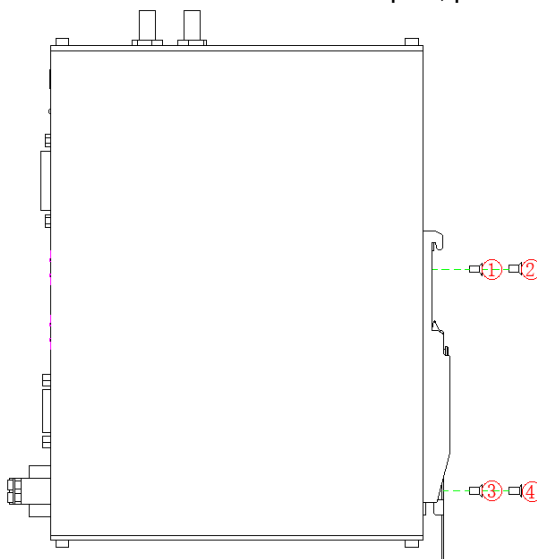

Figure 65 Attach DIN-Rail mounted part



1. Do not tighten screws with excess force.
2. Screw holes may be damaged if screws are tightened with a torque greater than the specified torque. The specified tightening torque is 5-6 kgf·cm.

3.1.1.3 SSD Setup

1. Unscrew four screws(①~④) in the aluminum radiator.
2. Remove the aluminum radiator(⑩).
3. Then you can install or uninstall the SSD(⑪ or ⑫).

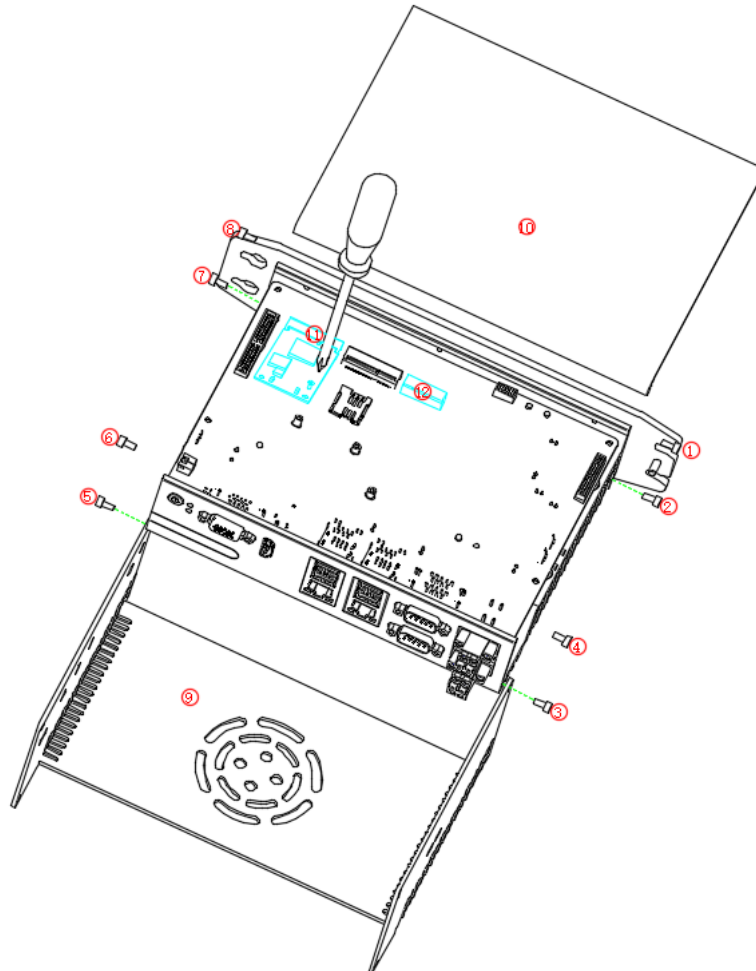

Figure 66 SSD Setup



- :
1. Must disconnect the power supply before operating.
 2. Pay attention to electrostatic discharge.
 3. Do not tighten screws with excess force.

3.1.1.4 MiniPCIE Setup

1. Unscrew four screws(①~④) in the aluminum radiator.
2. Remove the aluminum radiator(⑩).
3. Then you can install or uninstall the miniPCIE(⑪).

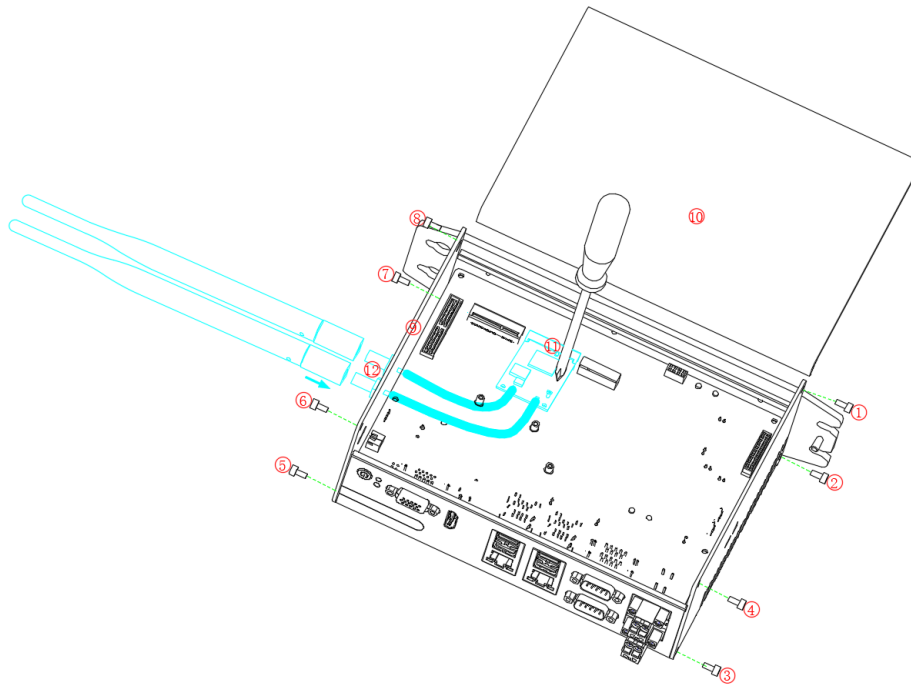

Figure 67 miniPCIE Setup

3.1.1.5 USB dongle Setup

1. Unscrew four screws(①~④) in the aluminum radiator.
2. Remove the aluminum radiator(⑨).
3. Then you can install or uninstall the USB device(⑩).

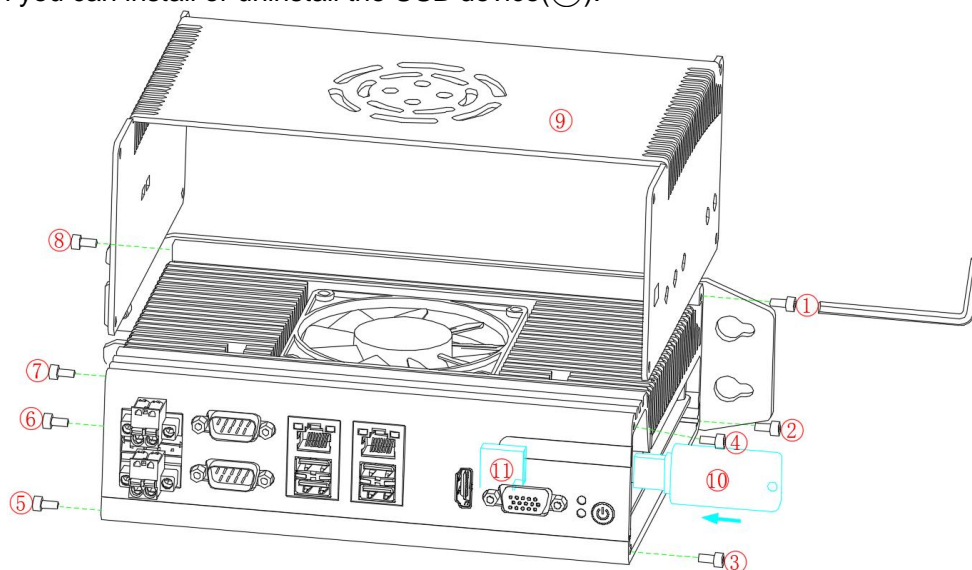

Figure 68 USB dongle Setup

3.1.1.6 Fan Setup

1. Unscrew four screws(①~⑬) in the aluminum radiator.
2. Remove the aluminum radiator(⑨).
3. Then you can install or uninstall the USB device(⑮).

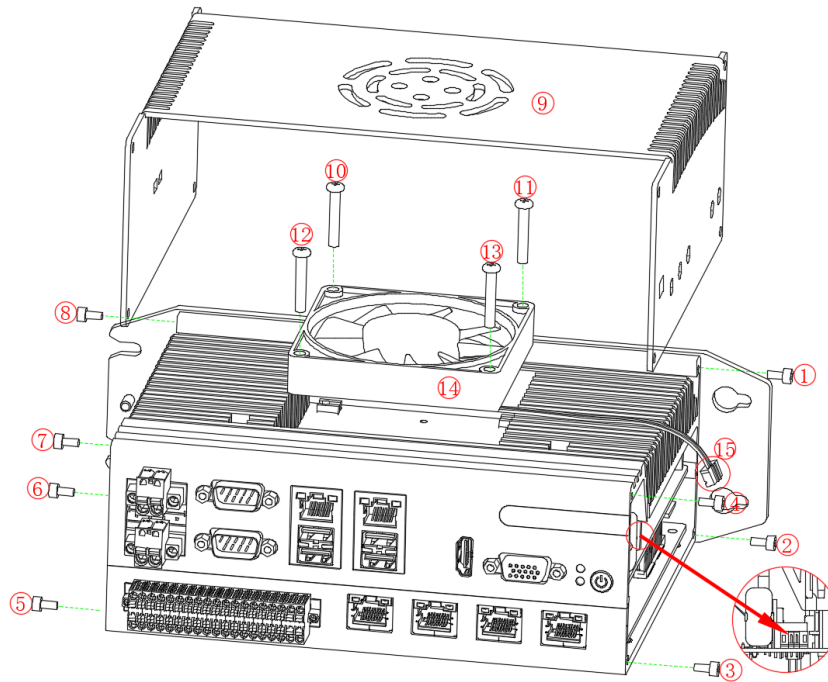

Figure 69 Fan Setup

3.1.2 Driver Setup

1. Download the driver install files from Nodka website or ask for support from your retailer.
2. Install the driver software according to the installation wizard.

4 Safety and Maintenance

Please follow the precautions described in this chapter, otherwise may cause device damaged.

4.1 Safety Precautions

Please follow the safety precautions described in this section below.

4.1.1 General Safety Precautions

Please ensure that the following safety precautions are followed:

- Follow electrostatic precautions if you open the device;
- When installing, moving or modifying the device, ensure that the power is switched off and the power cable is disconnected;
- It is forbidden to use more than the specified voltage as this may cause a fire or electric shock;
- Electric shock may occur if the device chassis is opened while the device is running;
- Do not drop or insert any debris into the device vents;
- If large quantities of dust, water or liquid enter the device, disconnect the power supply and contact the supplier;
- The following are prohibited:
 - It is forbidden to drop the device on a hard surface;
 - It is forbidden to knock or apply excessive force to the device;
 - It is forbidden to use the device in places where the rated environment exceeds the standard.

4.1.2 ESD Precautions

Failure to take ESD precautions during device installation may result in damage to the device or injury to the user. Electrostatic discharge (ESD) can cause damage to the components of a device. Dry climates are more prone to ESD. Therefore, the following anti-static precautions need to be strictly followed when opening the equipment:

- Wearing anti-static bracelet;
- Personally well grounded: When handling electronic components, grounded conductive substances should be touched frequently;
- Using anti-static mats: Electronic components should be operated on anti-static mats, which can reduce the possibility of ESD damage.
- Touch only the edges of electronic components: operate by holding the edge of electronic components.

4.1.3 Product Disposal

Disposal of used batteries must be in accordance with local environmental regulations.

- Outside the European Union:

If you want to dispose the used electrical and electronic products outside the European Union, please contact your local authority so as to comply with the correct disposal method.

- Within the European Union:

EU-wide legislation, as implemented in each Member State, requires that waste electrical and electronic products carrying the mark (right) must be disposed of separately from normal household waste. This includes monitors and electrical accessories, such as signal cables or power cords. When you need to dispose of your display products, please follow the guidance of your local authority, or ask the shop where you purchased the product. The mark on electrical and electronic products only applies to the current European Union Member States. Please follow the national guidelines for electrical and electronic product disposal.



4.2 Maintenance and Cleaning Precautions

Please follow the guidelines below when maintaining or cleaning the product.

4.2.1 Maintenance and Cleaning

Prior to cleaning any part or component of the product, please read the details below:
Never spray or squirt liquids directly onto any other components.

- The interior does not require cleaning. Keep fluids away from the interior.
- Be careful not to damage the small, removable components inside.
- Turn off before cleaning.
- Never drop any objects or liquids through the openings.
- Be cautious of any possible allergic reactions to solvents or chemicals used when cleaning.
- Avoid eating, drinking and smoking nearby.
- Fans are regularly cleaned of dust.

4.2.2 Cleaning Tools

Some components may only be cleaned using special tool for the safety. In such case, the product will be explicitly mentioned in the cleaning tips.
Below is a list of items to be used for cleaning.

- **Cloth** – Although paper towels or tissues can be used, a soft, clean piece of cloth is recommended.
- **Water or rubbing alcohol** – A cloth moistened with water or rubbing alcohol should be used;
- **Using solvents** – The use of solvents is not recommended as they may damage the plastic parts.
- **Vacuum cleaner** – Using a vacuum specifically designed for computers is one of the best methods of cleaning. Dust and dirt can restrict the airflow and cause circuitry to corrode.
- **Cotton swabs** - Cotton swabs moistened with rubbing alcohol or water are excellent tools for wiping hard to reach areas.
- **Foam swabs** - Whenever possible, it is best to use lint free swabs such as foam swabs for cleaning.

5 Q&A

This section explains and illustrates common problems that users may encounter when using the product.

5.1 Digital IO Electrical Wiring Diagram

The below sections can be referred to by the field electrical engineer.

5.1.1 Remote Electrical Wiring Diagram

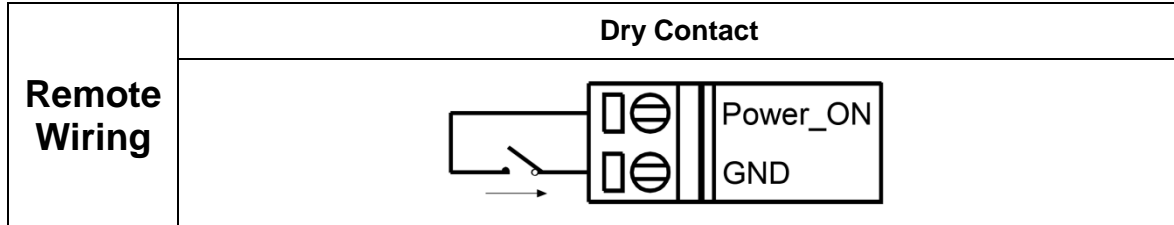

Figure 70 Remote wiring

5.1.2 H1/JH2 Electrical Wiring Diagram

5.1.2.1 DI Electrical Wiring Diagram

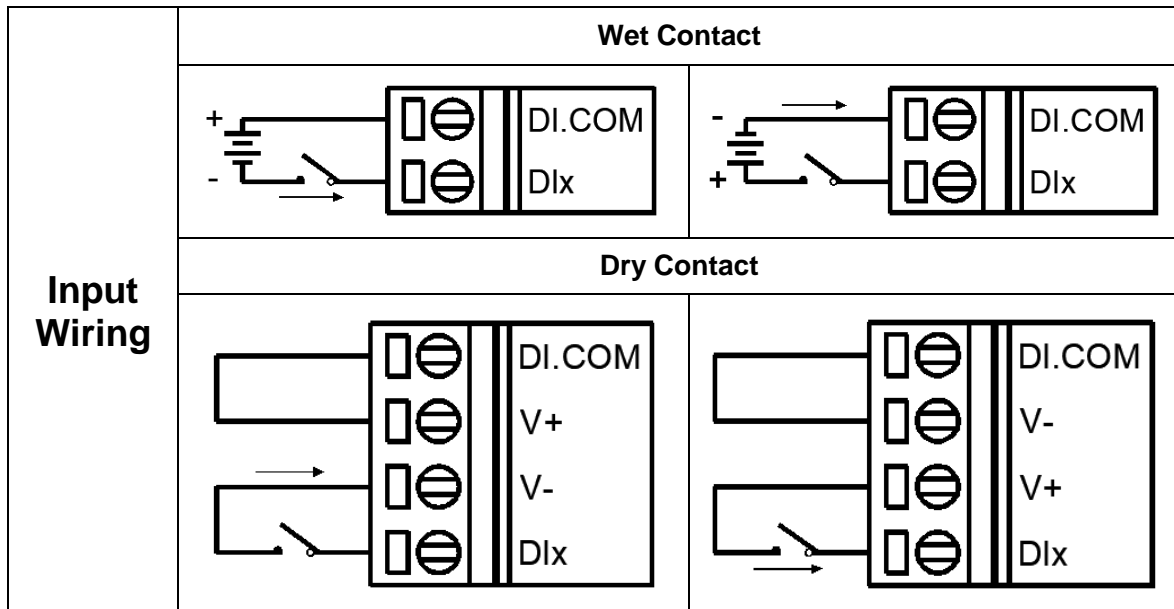

Figure 71 H1/JH2 DI wiring

5.1.2.2 DO Electrical Wiring Diagram

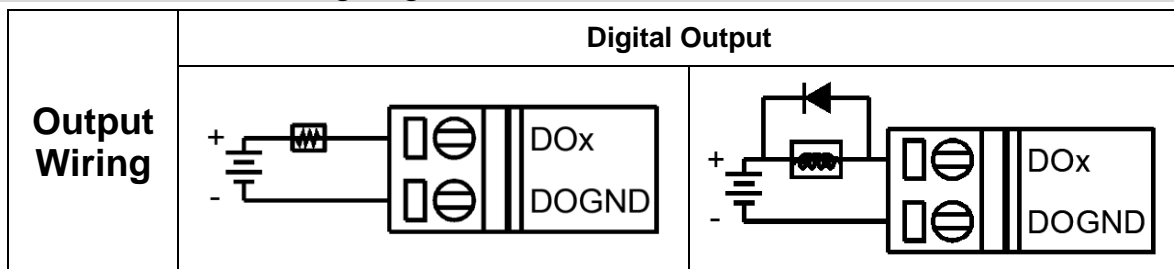

Figure 72 H1/JH2 DO wiring

5.1.2.3 Light Control Electrical Wiring Diagram

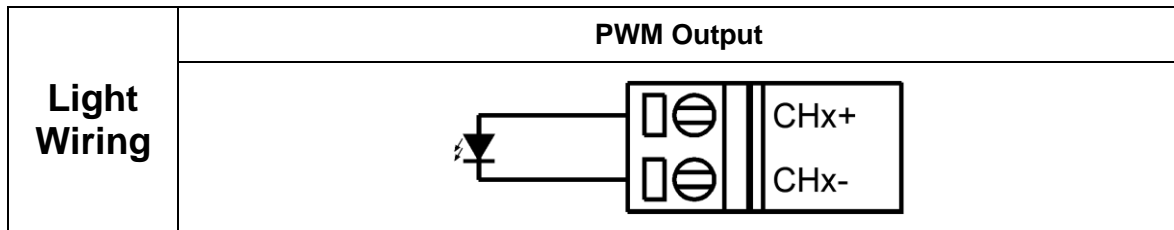

Figure 73 H1/JH2 Light source wiring

5.1.2.4 Light Control External Hard Trigger Electrical Wiring Diagram

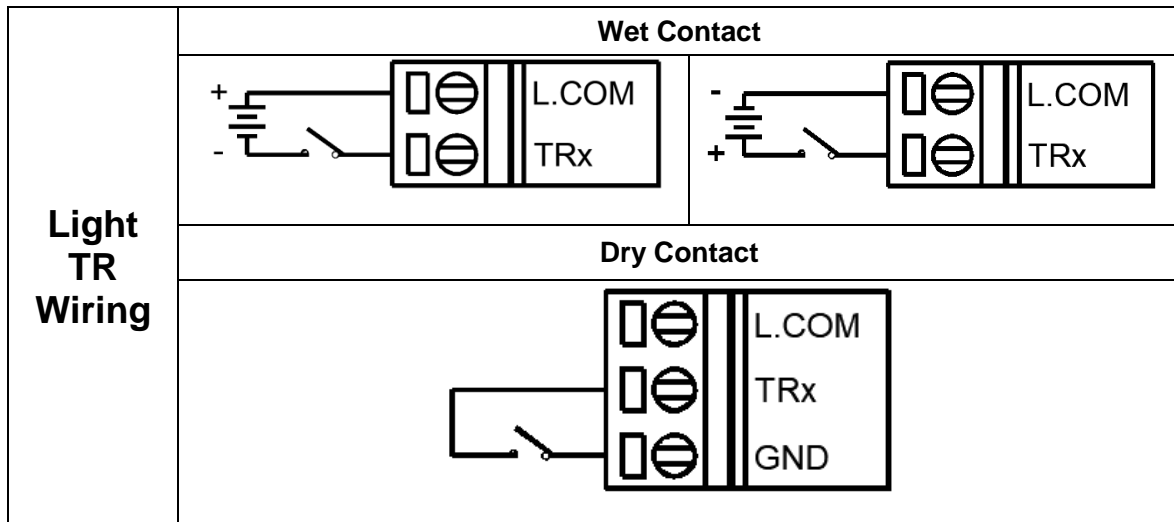

Figure 74 H1/JH2 Light source trigger wiring

5.1.3 H1B/JH2B Electrical Wiring Diagram

5.1.3.1 DI Electrical Wiring Diagram

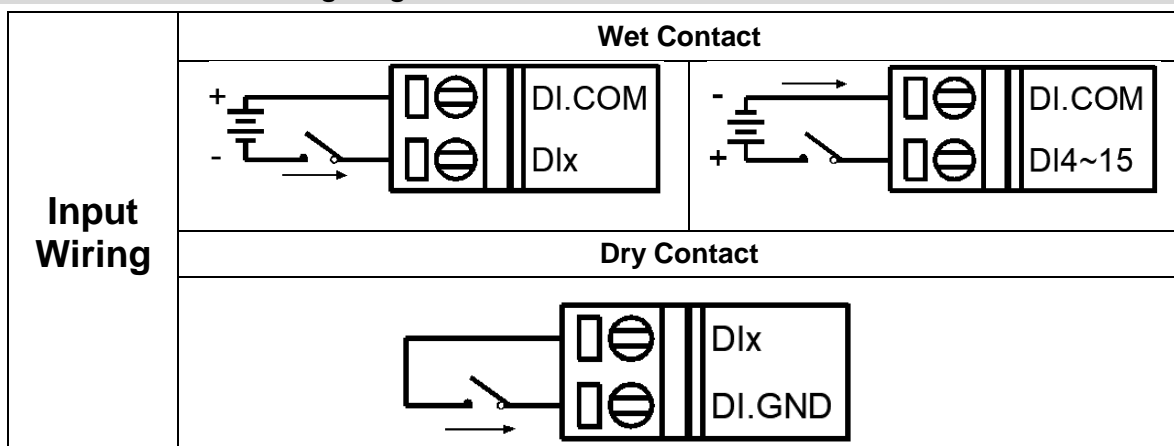

Figure 75 H1B/JH2B DI wiring

5.1.3.2 DO Electrical Wiring Diagram

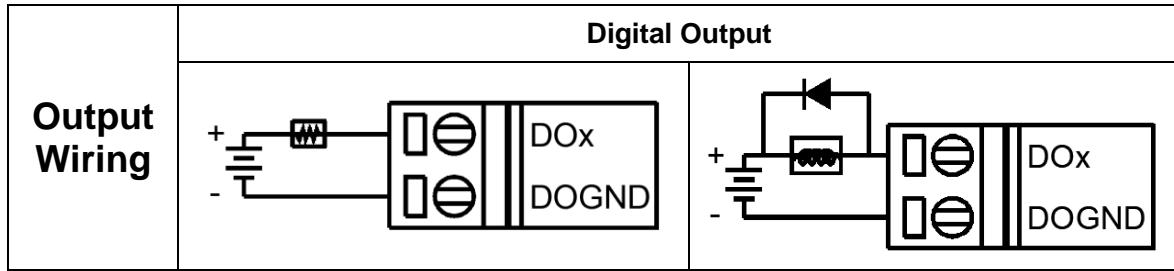

Figure 76 H1B/JH2B DO wiring

5.1.4 JH3 Electrical Wiring Diagram

5.1.4.1 DI Electrical Wiring Diagram

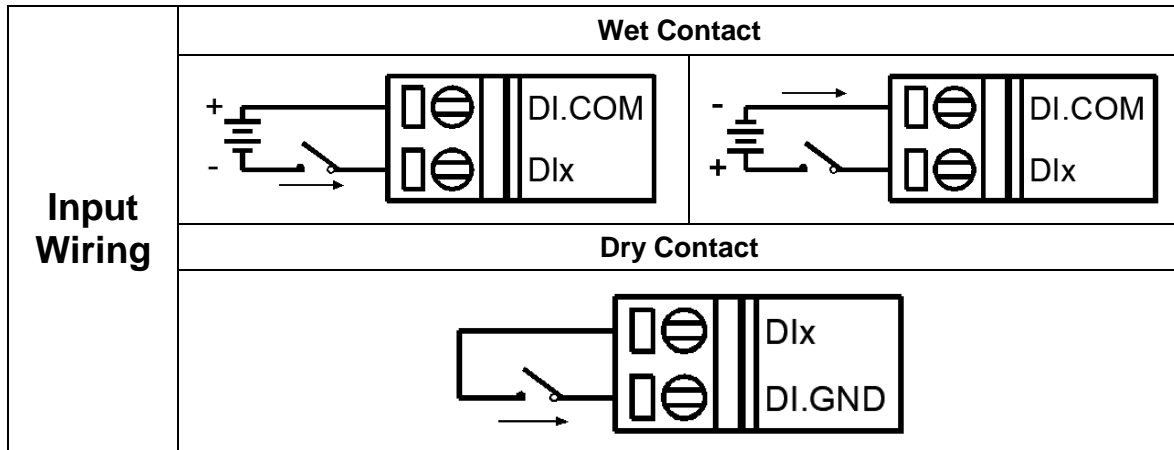

Figure 77 JH3 DI wiring

5.1.4.2 DO Electrical Wiring Diagram

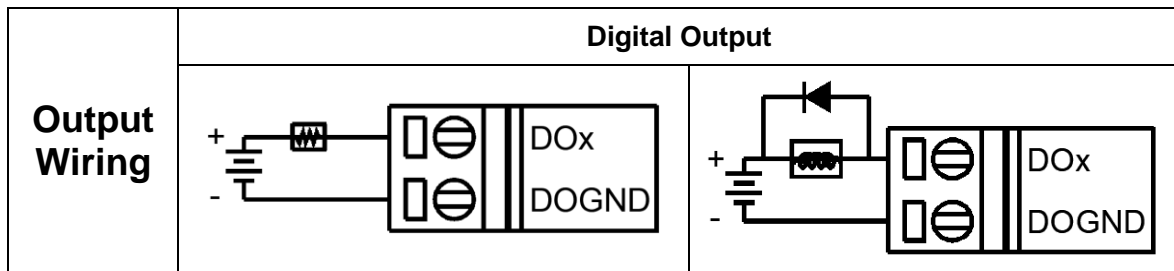

Figure 78 JH3 DO wiring

5.1.5 JH4 Electrical Wiring Diagram

5.1.5.1 DI Electrical Wiring Diagram

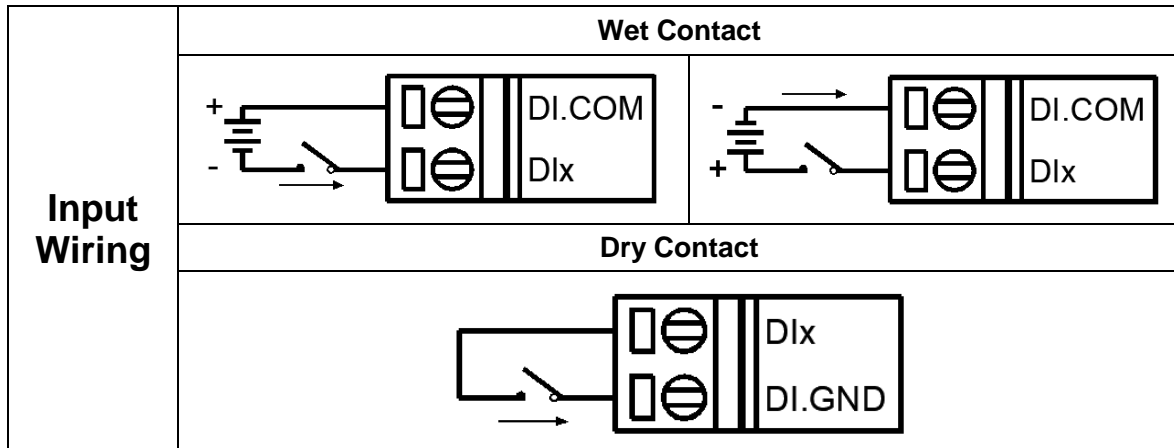

Figure 79 JH4 DI wiring

5.1.5.2 DO Electrical Wiring Diagram

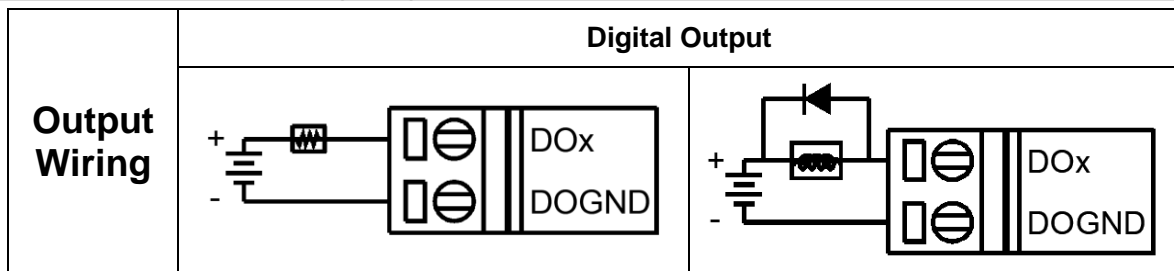

Figure 80 JH4 DO wiring

5.2 How to test the DO using multimeter

When DO works as OC gate output, its internal equivalent is a triode circuit controlled by the base. You can adjust the multimeter to the buzzer position, with the red probe connected to DOx and the black probe connected to DOGND. Then turn on the DOx in the application, and the multimeter buzzer will be on if the DO is on, otherwise multimeter buzzer will not be on.

5.3 Technical Support and Services

For documentation and related drivers, please visit Nodka’s website “<https://nodka.eu/>” or contact your local distributors for support and service.