



# PANEL5000-C1852W-L

v1.1 Touch Screen Monitor

---



18.5" Capacitive Touch Screen Monitor



## Specifications

General	Control button	Set Contrast ratio and Luminance via OSD at the back panel
	Dimensions (W x H x D)	480mm x 304mm x 47mm (18.90" x 11.97" x 1.85")
	Drill Hole Size (W x H)	463mm x 287mm (18.23" x 11.30")
	Box structure	Front panel: aluminum-magnesium alloy, anodized coating; Back cover: SGCC, Ground isolation protection
	Mounting	Support panel mounted, wall-mounted, Desktop (VESA 75x75 & 100x100)
	Power Supply	DC 12 - 24V
	Power Dissipation	10W
	Signal input	VGA & DVI-D
	Weight	4.6kg(10.14lb)
LCD	LCD Size	18.5" HD TFT
	Resolution	1366 x 768
	Colors	16.7MB
	Active Area (W x H)	409.8mm x 230.4mm
	Backlight	LED
	MTBF	30000hrs
	Pixel pitch(H x V)	0.1 x 0.3
	Luminance	250cd/m <sup>2</sup>
	Contrast Ratio	1000 : 1
	Viewing Angle	(L) 89 / (R) 89 / (T) 89 / (B) 89
Touchscreen	Type	Multi-point capacitive touch screen
	Transmittance	> 87%
	Controller interface	USB
	Driver Support	Windows XP, Windows 7, Winows8, Windows 10, Linux
	Multi-touch	10 points (windows system)
	Surface Hardness	Mohs' Number 7H
Environmental	Operating Temperature	0 ~ 50° C (32~122 °F )
	Storage Temperature	-20 ~ 60° C (-4 ~ 140 °F )
	Relative humidity	10~95% RH@40°C,non-condensing
	Vibration	Operating Random Vibration Test 5~500Hz, 1.5Grms@with SSD, follow IEC 60068-2-64
	Shock	Operating 10G peak acceleration (11ms duration), follow IEC 60068-2-27
	EMC	CE/FCC Class B
	Front panel protection	IP65 compliant

## Dimensions:

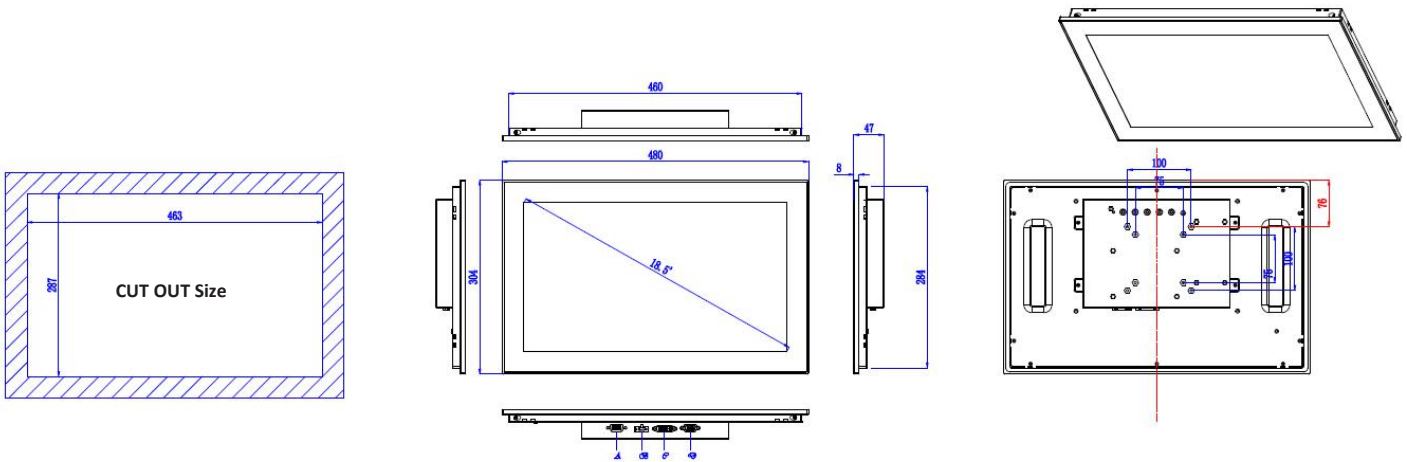

A:USB	B:DC IN	C:DVI-D	D:VGA
-------	---------	---------	-------

## Ordering

Product Code	Description
PANEL5000-C1852W-L	18.5" TFT LCD/Capacitive Touch Screen/DC12-24V input/1366*768

## Packing List:

Mounting screws	8*pcs Thickness=1mm~1.2mm
Terminal	2pin Phoenix terminal
VGA Cable	1.8M
USB Cable	1.8M

## Optional Items:

Adapter	12V/3.33A,40W 2pin Phoenix terminal
Power Cord	1.8M/3M/5M
VGA Cable	3M/5M
USB Cable	3M/5M
DVI Cable	1.8M/3M/5M