

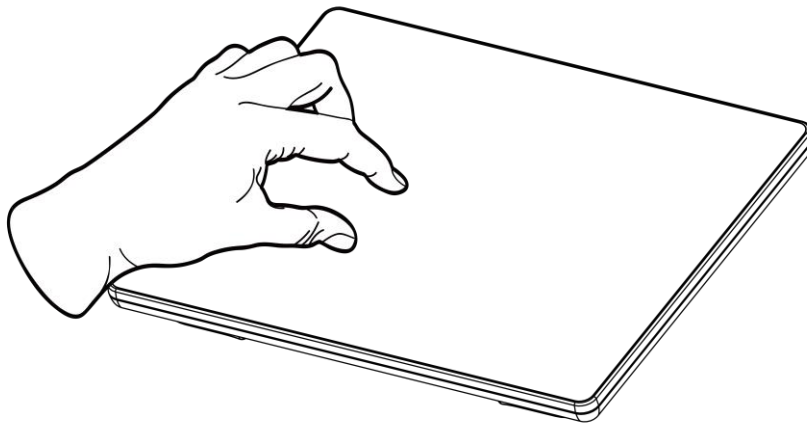

15" Multi-Touch Chassis HMI

Intel® Celeron® Bay Trail-M N2930 1.83GHz

R15IB3S-PTC3



Quick Start Guide

V1.0

Document Part Number : 91521110101U



Please read these instructions carefully before using this product, and save this manual for future use

Contents

1 Introduction	- 7 -
1.1 Unpacking	- 7 -
1.2 Description of Parts	- 8 -
2 Installation	- 9 -
2.1 Turning On	- 9 -
2.2 Connecting Peripherals	- 10 -
2.2.1 Power Connector	- 10 -
2.2.2 Ethernet Connector	- 10 -
2.2.3 Serial Port Connector	- 11 -
2.2.4 USB Connector	- 11 -
2.3 Speaker	- 12 -
3 Getting Started	- 13 -
3.1 Introduction	- 13 -
3.2 How to Enable Watchdog	- 14 -
3.3 Using Recovery Wizard to Restore Computer	- 16 -
Appendix A: Product Specifications	- 17 -

FCC Statement



This device complies with part 15 FCC rules.

Operation is subject to the following two conditions:

- This device may not cause harmful interference.
- This device must accept any interference received including interference that may cause undesired operation.

This equipment has been tested and found to comply with the limits for a class "B" digital device, pursuant to part 15 of the FCC rules. These limits are designed to provide reasonable protection against harmful interference when the equipment is operated in a commercial environment. This equipment generates, uses, and can radiate radio frequency energy and, if not installed and used in accordance with the instruction manual, may cause harmful interference to radio communications. Operation of this equipment in a residential area is likely to cause harmful interference in which case the user will be required to correct the interference at his own expense.

European Union



Electromagnetic Compatibility Directive (2014/30/EU)

- EN55024: 2010/ A1: 2015
 - IEC61000-4-2: 2009
 - IEC61000-4-3: 2006+A1: 2007+A2: 2010
 - IEC61000-4-4: 2012
 - IEC61000-4-5: 2014
 - IEC61000-4-6: 2014
 - IEC61000-4-8: 2010
 - IEC61000-4-11: 2004
- EN55032: 2012/AC:2013
- EN61000-3-2:2014
- EN61000-3-3:2013

Low Voltage Directive (2014/35/EU)

- EN 60950-1:2006/A11:2009/A1:2010/A12:2011/A2:2013

This equipment is in conformity with the requirement of the following EU legislations and harmonized standards. Product also complies with the Council directions.

Copyright Notice

No part of this document may be reproduced, copied, translated, or transmitted in any form or by any means, electronic or mechanical, for any purpose, without the prior written permission of the original manufacturer.

Trademark Acknowledgement

Brand and product names are trademarks or registered trademarks of their respective owners.

Disclaimer

Winmate Inc. reserve the right to make changes, without notice, to any product, including circuits and/or software described or contained in this manual in order to improve design and/or performance. We assume no responsibility or liability for the use of the described product(s) conveys no license or title under any patent, copyright, or masks work rights to these products, and make no representations or warranties that these products are free from patent, copyright, or mask work right infringement, unless otherwise specified. Applications that are described in this manual are for illustration purposes only. We make no representation or guarantee that such application will be suitable for the specified use without further testing or modification.

Warranty

Winmate Inc. warranty guarantees that each of its products will be free from material and workmanship defects for a period of one year from the invoice date. If the customer discovers a defect, we will, at his/her option, repair or replace the defective product at no charge to the customer, provide it is returned during the warranty period of one year, with transportation charges prepaid. The returned product must be properly packaged in its original packaging to obtain warranty service. If the serial number and the product shipping data differ by over 30 days, the in-warranty service will be made according to the shipping date. In the serial numbers the third and fourth two digits give the year of manufacture, and the fifth digit means the month (e. g., with A for October, B for November and C for December).

For example, the serial number 1W14Axxxxxxx means October of year 2014.

Customer Service

We provide a service guide for any problem by the following steps: First, visit the website of our distributor to find the update information about the product.

Second, contact with your distributor, sales representative, or our customer service center for technical support if you need additional assistance.

You may need the following information ready before you call:

- Product serial number
- Software (OS, version, application software, etc.)
- Description of complete problem
- The exact wording of any error messages

In addition, free technical support is available from our engineers every business day. We are always ready to give advice on application requirements or specific information on the installation and operation of any of our products.

Advisory Conventions

Four types of advisories are used throughout the user manual to provide helpful information or to alert you to the potential for hardware damage or personal injury. These are Notes, Important, Cautions, and Warnings. The following is an example of each type of advisory.



NOTE:

A note is used to emphasize helpful information



IMPORTANT:

An important note indicates information that is important for you to know.



CAUTION/ ATTENTION

A Caution alert indicates potential damage to hardware and explains how to avoid the potential problem.

Unalerted' attention indique un dommage possible à l'équipement et explique comment éviter le problem potentiel.



WARNING!/AVERTISSEMENT!

An Electrical Shock Warning indicates the potential harm from electrical hazards and how to avoid the potential problem.

Un Avertissement de Choc Électrique indique le potentiel de choc sur des emplacements électriques et comment éviter ces problèmes.

Safety Information

WARNING! / AVERTISSEMENT!



Always completely disconnect the power cord from your chassis whenever you work with the hardware. Do not make connections while the power is on. Sensitive electronic components can be damaged by sudden power surges. Only experienced electronics personnel should open the PC chassis.

Toujours débrancher le cordon d'alimentation du chassis lorsque vous travaillez sur celui-ci. Ne pas brancher de connexions lorsque l'alimentation est présente. Des composantes électroniques sensibles peuvent être endommagées par des sauts d'alimentation. Seulement du personnel expérimenté devrait ouvrir ces chassis.

CAUTION/ATTENTION



Always ground yourself to remove any static charge before touching the CPU card. Modern electronic devices are very sensitive to static electric charges. As a safety precaution, use a grounding wrist strap at all times. Place all electronic components in a static-dissipative surface or static-shielded bag when they are not in the chassis.



Toujours vérifier votre mise à la terre afin d'éliminer toute charge statique avant de toucher la carte CPU. Les équipements électroniques modernes sont très sensibles aux décharges d'électricité statique. Toujours utiliser un bracelet de mise à la terre comme précaution. Placer toutes les composantes électroniques sur une surface conçue pour dissiper les charge, ou dans un sac anti-statique lorsqu'elles ne sont pas dans le chassis.



1 Introduction

1.1 Unpacking

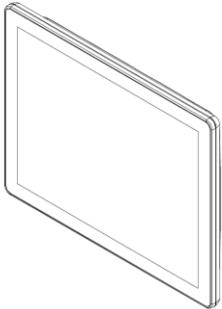
Check and identify the supplied accessories

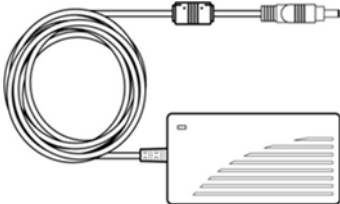
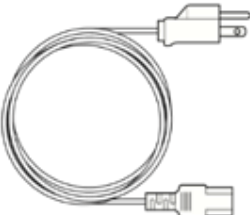
		
<p align="center">HMI</p>	<p align="center">Quick Start Guide (Hardcopy)</p>	<p align="center">Driver CD</p>
<p>Varies by product specifications</p>	<p align="center">91521110101U</p>	<p align="center">IB32S: 91711111103M</p>
		
<p align="center">AC Adapter (12V/ 50W)</p>	<p align="center">Power Cord</p>	
<p align="center">922D050W12VA</p>	<p align="center">Varies by country</p>	

1.2 Description of Parts

R15IB3S-PTC3

Unit: mm

Dimensions: 352.50 x 276.70 x 45

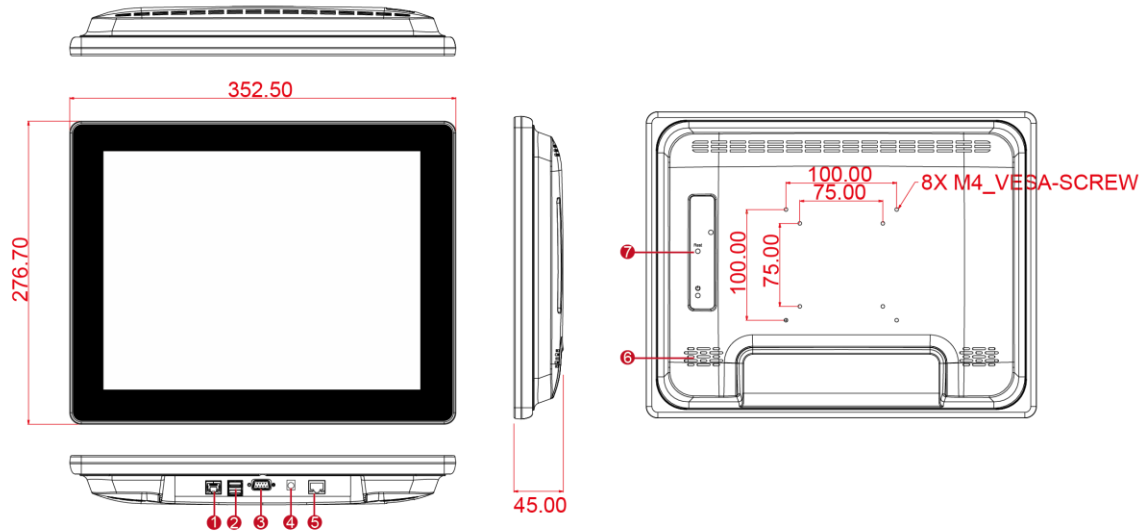

Connectors

No	Description	No	Description
①	RJ-45 (LAN)	⑤	RJ-45 (LAN/PoE)
②	USB 3.0, USB 2.0	⑥	1 Watt Speaker
③	RS-232/422/485 (DB9)	⑦	Power & Reset button
④	12V DC Power Jack		

2 Installation

2.1 Turning On

Follow the following steps to turn on your device:

1. Connect AC adapter to DC jack connector of the HMI.
2. Connect the power cord to AC adapter.
3. Plug the power cord to the AC outlet.
4. Press **Power** button on the rear OSD panel.

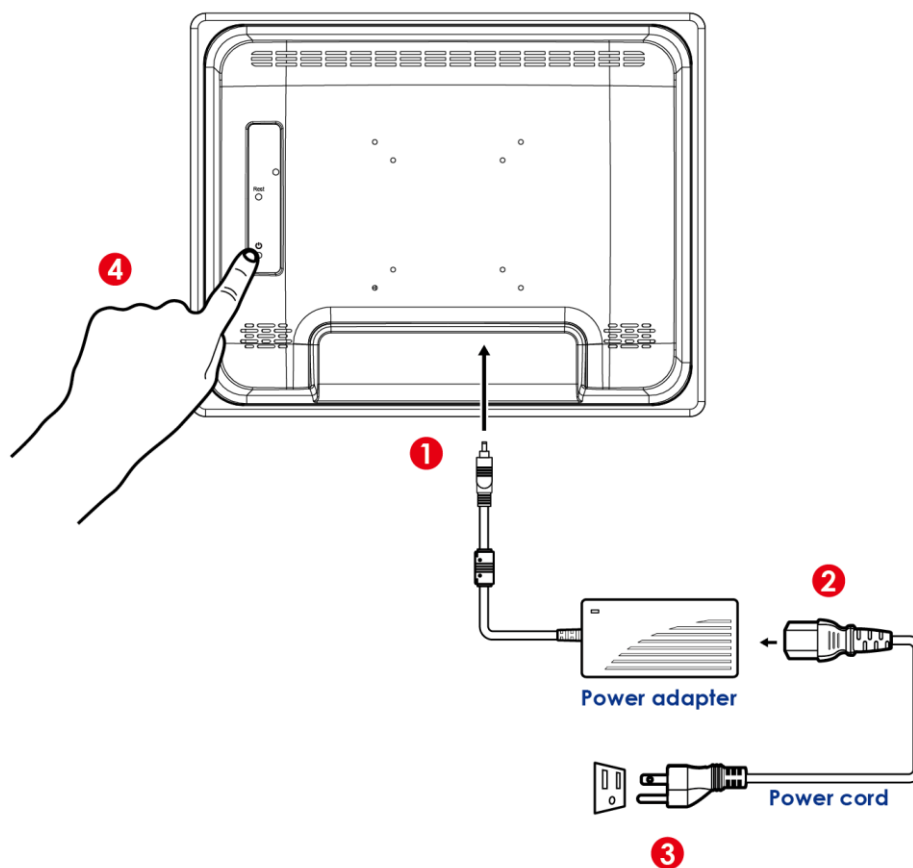

CAUTION

Use only the AC adapter included in your package.
Using other AC adapters may damage the device.



ALTERNATING CURRENT

This product must be grounded. Use only a grounded AC outlet. Install the additional PE ground wire if the local installation regulations require it.

2.2 Connecting Peripherals

This section lists HMI connectors and pin assignment.

2.2.1 Power Connector

DC power source input is a DC-in power jack connector that accepts 12V DC power input.

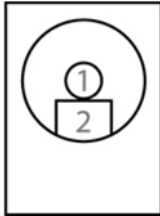

Pin №	Name	Pin №	Name
1	DC_IN	2	GND



Voltage

Minimum Voltage 11.4V
Maximum Voltage 12.6V
Maximum Current 4.2A

2.2.2 Ethernet Connector

The HMI has two RJ45 connectors that support 10/100/1000 Mbps Ethernet interface for connecting to the internet. Notice that only one RJ45 connector supports PoE function.

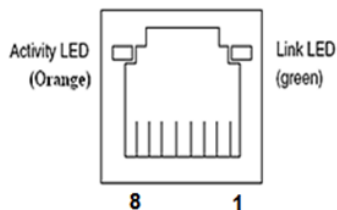

Pin №	Signal Name	Pin №	Signal Name
1	TX1+	2	TX1-
3	TX2+	4	TX2-
5	TX3+	6	TX3-
7	TX4+	8	TX4-



IMPORTANT:

Power Device (PD): IEEE 802.3at (25 Watt)

2.2.3 Serial Port Connector

Use COM1 serial port connector to connect your HMI to external devices such as mouse, modem or printer. You can configure serial port settings via jumpers located on the motherboard.

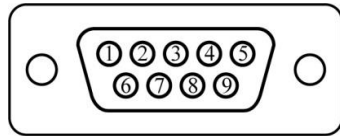

Pin No	RS232	RS422	RS485
1	DCD	TxD-	D-
2	RXD	TxD+	D+
3	TXD	RxD+	NC
4	DTR	RxD-	NC
5	GND	GND	GND
6	DSR	NC	NC
7	RTS	NC	NC
8	CTS	NC	NC
9	RI	NC	NC

2.2.4 USB Connector

The HMI has USB 2.0 and USB 3.0 combined connector. Use USB connector to connect your device to other USB compatible devices such as mouse, keyboard and printer.

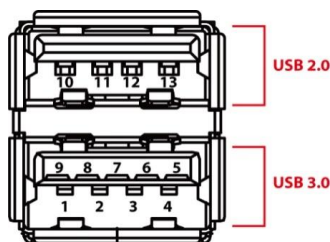

Pin No	Signal Name	Pin No	Signal Name
1	+5V	2	USB_D-
3	USB_D+	4	GND
5	STDA_SSRX-	6	STDA_SSRX+
7	GND_DRAIN	8	STDA_SSTX-
9	STDA_SSTX+	10	+5V
11	USB_D-	12	USB_D+
13	GND		

2.3 Speaker

Speaker is located on the rear side of the HMI.

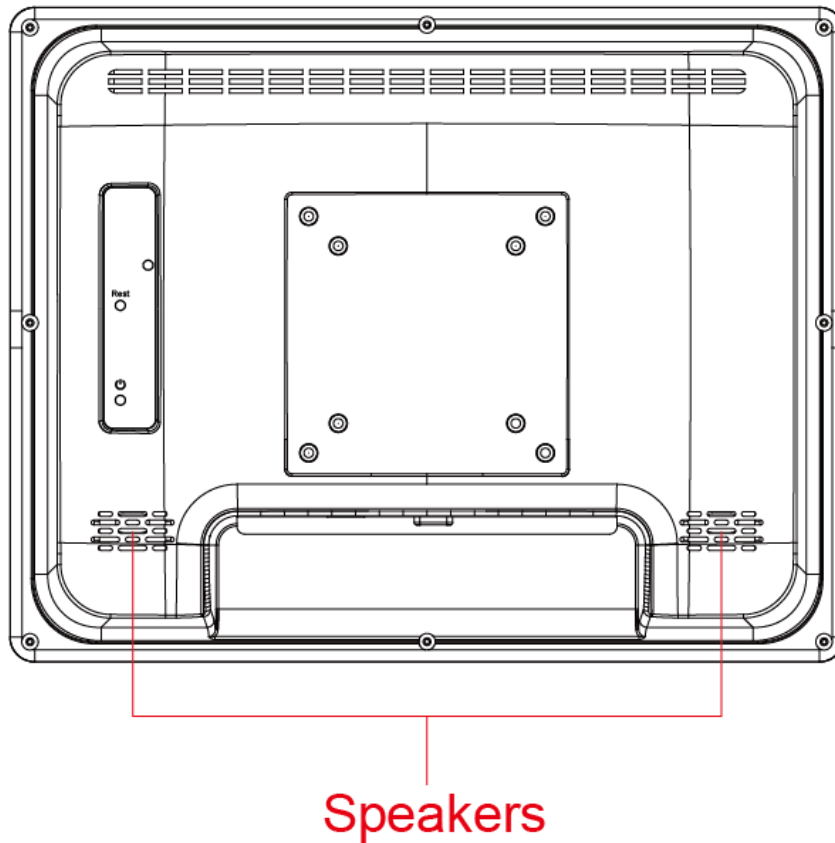

Electrical Specifications	
Rated impedance	6±15% ohms@2KHz, 1 Vrms input
Power Rating	0.67 W
Short Term Max Power	1.3W
Acoustical Specifications	
Sound Pressure Level	75±3dB/40cm@1kHz

3 Getting Started

3.1 Introduction

Your HMI supports several versions of Windows OS:

- Windows 10 IoT
- Windows Embedded 8.1 Industry Pro
- Windows Embedded 7 Standard





IMPORTANT:

The device is shipped with the OS System according to your order. Contact us if you have any questions regarding OS settings.

3.2 How to Enable Watchdog

To enable Watchdog, you need to download Winmate Watchdog utility. Find more information on Watchdog in “Watchdog Guide” that you can download from [Winmate Download Center](#).

To enable watchdog in Watchdog AP follow the instructions below:

1. On the right bottom side of the desktop screen, click  **triangle button** to show hidden icons.
2. Click  icon to open Watchdog utility.

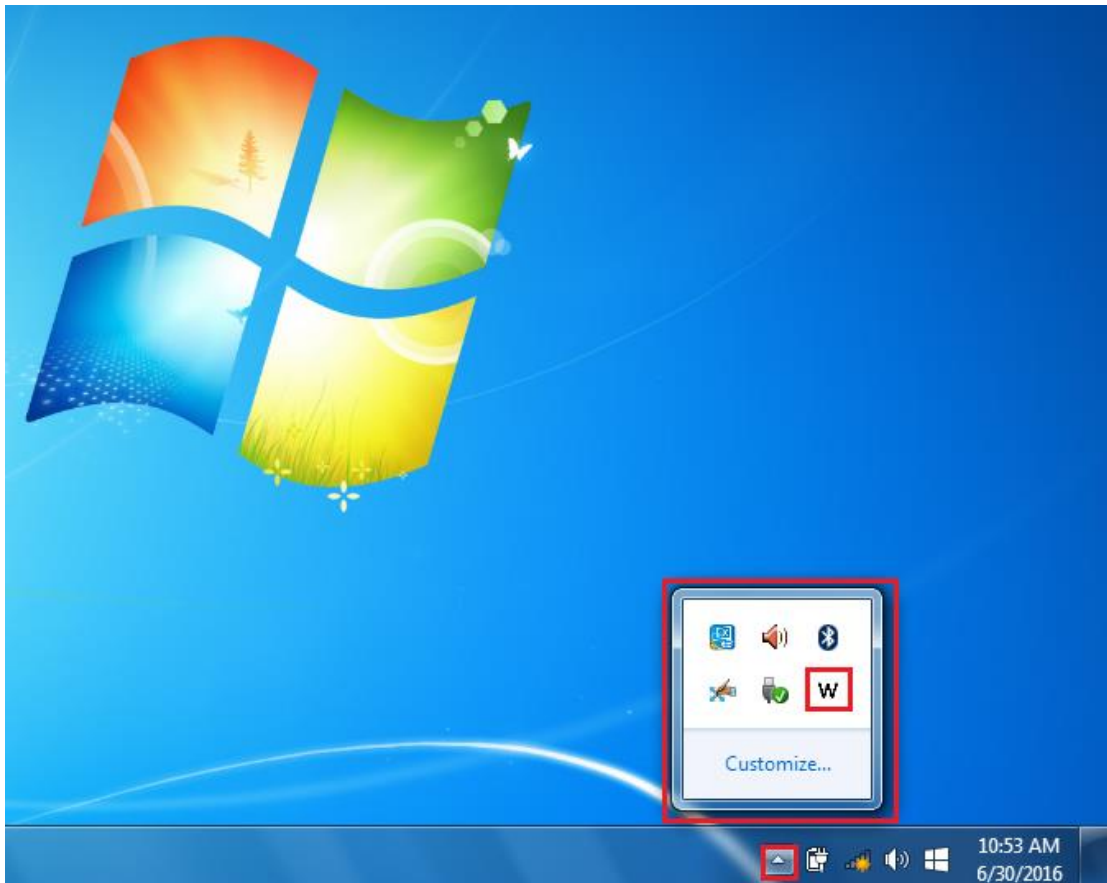

- In Watchdog utility window set countdown time and periodically feed time, or disable watchdog.

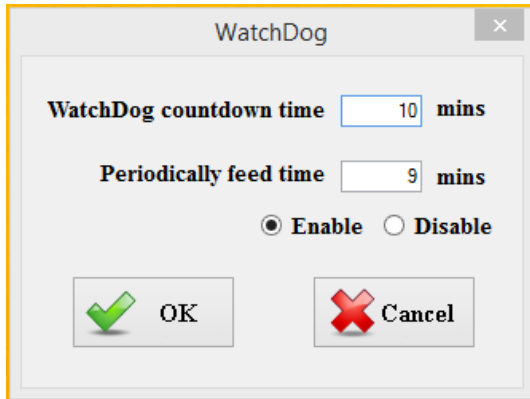

Example:

Every 10 min watchdog will monitor the system, in case any error occurs the system will restart automatically when the countdown time reaches 0.

Every 9 min watchdog timer will be reset to 10 min.

Settings	Description
Watchdog Countdown Time	The system automaticity restarts when this countdown time reaches zero. <i>Default: 10 min</i>
Periodically Feed Time	To set a cycle time to automatically reset watchdog timer. <i>Default: 9 min</i>
Enable / Disable	Enable or disable watchdog. <i>Default: Enable</i>

3.3 Using Recovery Wizard to Restore Computer



Note:

Before starting the recovery process, make sure to backup all user data. The data will be lost after the recovery process.

To enable quick one-key recovery procedure:

1. Connect the computer to the power source. Make sure the computer stays plugged in to power source during the recovery process.
2. Turn on the computer, and when the boot screen shows up, press **Tab+ F6** to initiate the Recovery Wizard.
3. The following screen shows the Recovery Wizard. Click **Recovery** button to continue.



4. A warning message about data loss will show up. Make sure the data is backed up before recovery, and click **Yes** to continue.



Wait the recovery process to complete. During the recovery process, a command prompt will show up to indicate the percent of recovery process complete. The system will restart automatically after recovery completed.

Appendix A: Product Specifications

Model Name	R15IB3S-PTC3	
Display	Size/Type	15" TFT
	Resolution	1024 x 768
	Brightness	300 <i>cd/m²</i>
	Contrast Ratio	700:1 (typ.)
	Viewing Angle	~80~80 (H); ~80~80 (V)
	Max Colors	16.2M
	Front Side Glass	Yes (Optional)
	Touch	Projected Capacitive Touch (Default)
System Specifications	Processor	Intel® Celeron® Bay Trail-M N2930 1.83 GHz
	Chipset	Intel® ATOM™ SoC Integrated
	Memory	2GB DDR3L-1600 SODIMM (max 8GB)
	Storage	64GB M.2 SSD
	Security Support	Trusted Platform Module (TPM 1.2)
	LAN	Dual Intel® I210-AT GbE LAN
	OS	Windows 10 IoT Enterprise Windows Embedded 8.1 Industry Pro Windows Embedded 7 Standard
Input/ Output	Serial Port	1 x RS-232/422/485 (DB9)
	USB	1 x USB 3.0, 1 x USB 2.0
	Ethernet	1 x RJ 45-10/100/1000 Mbps (LAN) 1 x RJ 45(PoE)
	Speaker	2 x 1W Speakers
	Power Connector	1 x DC-in Power Jack
Power Specifications	Power Input	12V DC
	Power Consumption	21W typical, normal operation
	Optional Power over Ethernet	Power Device (PD): follows IEEE 802.3at (25 W) <i>*PoE support condition: recommended to use without other power-consuming devices</i>
Mechanical Specification	Mounting	VESA Mount (100x100 mm, 75x75 mm)
	Dimensions (W x H x D)	352.5 x 276.7 x 45 (mm)
	Housing	Color RAL 7016 Plastic casing

	Buttons	Power, Reset
Environment Considerations	Operating Temperature	0°C to 40°C
	Storage Temperature	-10°C to 50°C
	Humidity	30%~90% (non-condensing)
	Certification	CE, FCC Class A, UL, RoHS Directive 2011/65/EU



Winmate Inc.

9F, No.111-6, Shing-De Rd., San-Chung District,
New Taipei City 24158, Taiwan, R.O.C

Tel: 886-2-8511-0288

Fax: 886-2-8511-0211

Email: sales@winmate.com.tw

Official website: www.winmate.com
