

# W15L100-PTA3

## 15.6" Multi-Touch Chassis Display



### KEY FEATURES

- 15.6" 1920 x 1080 Resolution
- VGA input and HDMI input
- Stylish and elegant design
- Front IP65



### SPECIFICATIONS

Display	
<b>Resolution</b>	1920x1080
<b>Contrast Ratio</b>	800:1
<b>Display Color</b>	262K Colors
<b>Active Area</b>	344.16x193.59 mm
<b>Size</b>	15.6 inches
<b>Panel Brightness</b>	400.0 nits
<b>View Angles</b>	85,85,85,85
<b>Touch / Glass</b>	Projected Capacitive Multi Touch Screen Anti-glare Film (Optional)
Environment	
<b>Operating Humidity</b>	10% to 90% RH, Non-Condensing
<b>Storage Temperature</b>	-10°C to 60°C
<b>Operating Temperature</b>	0°C to 50°C
Certification	
<b>Certification</b>	CE, FCC
IO Ports	
<b>USB Port</b>	1 x USB for Touch Screen
<b>Audio</b>	1 x Audio Line In 2 x Speaker (Optional)
<b>Video</b>	1 x VGA 1 x HDMI (Optional)
Mechanical	
<b>Dimension</b>	387.8 x 232.9 x 40 mm
<b>Mounting</b>	VESA Mount
<b>Cooling System</b>	Fanless Design
<b>Weight</b>	1.7 kg
<b>Enclosure</b>	Plastic
Accessory	
<b>Accessory</b>	1 x VGA cable 1 x HDMI cable 100~240V AC to DC Adapter Power Cord Manual VESA screws(Varies by product)
Power	
<b>Power Rating</b>	12V DC in 24V DC in (optional)
Control	

**DIMENSIONS** UNIT:MM

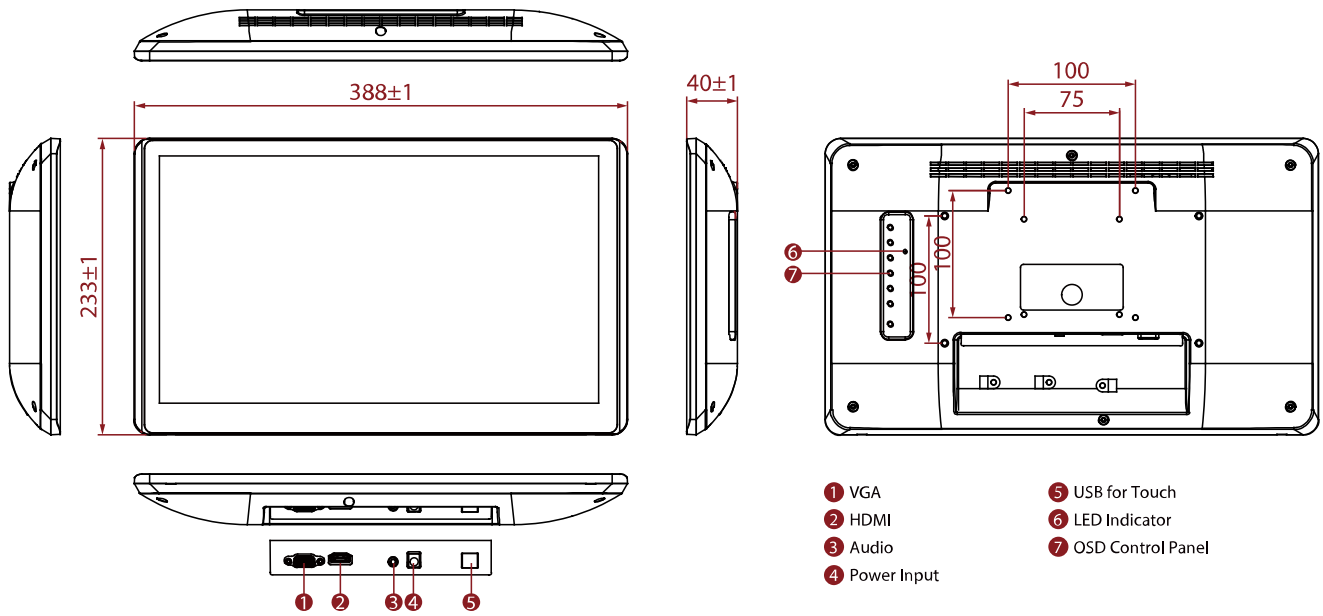

**NOTE**

1. This is a simplified drawing and some components are not marked in detail.
2. Please contact our sales representative if you need further product information.
3. All specifications are subject to change without prior notice.
4. The product shown in this datasheet is a standard model. For diagrams that contain customized or optional I/O, please contact the Winmate Sales Team for more information.